

NOTES:

1/2" EXPANSION JOINTS ARE SHOWN AS DARK SOLID LINES FOR VISUAL PURPOSES.

BOND BREAKER IS SHOWN AS DARK DASHED LINES FOR VISUAL PURPOSES.

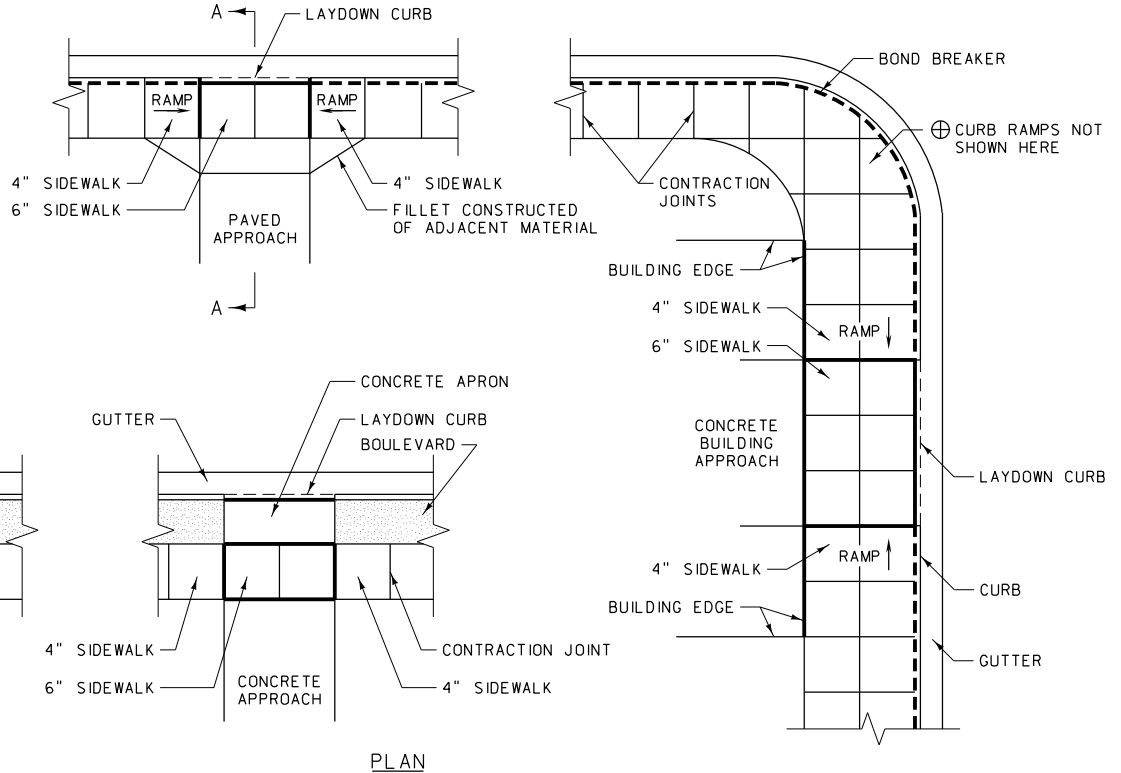

PLAN

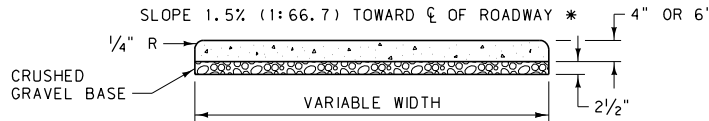

SECTION OF SIDEWALK

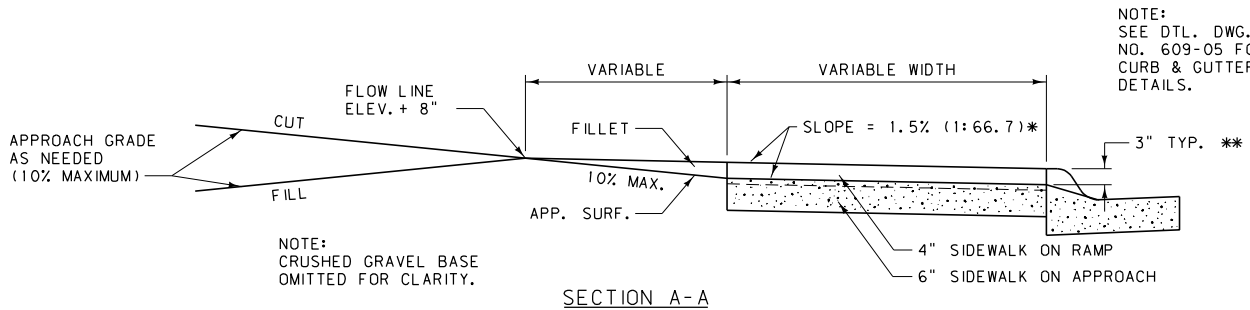

SECTION A-A

NOTE:
SEE DTL. DWG.
NO. 609-05 FOR
CURB & GUTTER
DETAILS.

NOTES:

INSTALL PREFORMED EXPANSION JOINT FILLER, STD. SPEC. 707.01.3, AT ALL EXPANSION JOINTS, FOR THE FULL THICKNESS OF THE SIDEWALK AND USE AT ALL JOINTS BETWEEN NEW CONCRETE SIDEWALK AND STRUCTURES IN PLACE.

INSTALL A BOND BREAKER FOR THE FULL THICKNESS OF THE SIDEWALK AT LOCATIONS SPECIFIED ON THIS DETAIL. USE A 15 OR 30 POUND ROOFING FELT MATERIAL, OR OTHER PRODUCT AS APPROVED BY THE ENGINEER, FOR THE BOND BREAKER. DO NOT USE EXPANSION JOINT MATERIAL AS A BOND BREAKER.

ALL JOINTS MUST BE STRAIGHT AND PERPENDICULAR TO THE CENTERLINE AND THE SURFACE OF THE SIDEWALK. WHERE PRACTICAL, ALIGN ALL JOINTS WITH LIKE JOINTS IN ADJOINING WORK. USE JOINTS TO OUTLINE ALL PANELS IN THE SIDEWALK, WHICH ARE TO BE, SO FAR AS POSSIBLE, SQUARE. THE LENGTHS OF THE PANELS ARE DETERMINED BY THE WIDTH OF THE SIDEWALK.

WHERE RIGHT-OF-WAY PERMITS, NEW SIDEWALKS LESS THAN 5 FEET IN WIDTH MUST HAVE A PASSING AREA AT A MAXIMUM SPACING OF 200 FEET. THE PASSING AREA IS A MINIMUM OF 5 FEET BY 5 FEET IN SIZE.

CONTRACTION JOINTS MAY NOT BE MORE THAN 1/8" WIDE AND NOT LESS THAN 1" IN DEPTH AND MAY BE CUT BY A GROOVE FORMING TOOL.

LOCATE EXPANSION JOINTS EVERY 100 FEET (± 30 FEET) AT INTERVALS EQUAL TO THE NEAREST MULTIPLE OF THE CONTRACTION JOINT INTERVAL.

USE A LONGITUDINAL CONTRACTION JOINT IN THE CENTERLINE OF ALL SIDEWALKS WIDER THAN 5 FEET.

* THE MAXIMUM CROSS SLOPE OF THE SIDEWALK IS 2% (1:50).

** THIS DEPTH IS STANDARD IN NEW CONSTRUCTION. ALTERATIONS TO EXISTING FACILITIES MAY RESULT IN A LARGER DEPTH, WHICH WILL REQUIRE A GREATER RAMP LENGTH.

⊕ SEE DTL. DWG. NO. 608-15 AND 608-20 FOR GUIDELINES ON RAMP DESIGN WHEN RAMPS ARE REQUIRED FOR ADA ACCESSIBILITY.

DETAILED DRAWING	
REFERENCE STANDARD SPEC. SECTION 608	DWG. NO. 608-05
CONCRETE SIDEWALK	
EFFECTIVE: FEBRUARY 2005	
 MONTANA DEPARTMENT OF TRANSPORTATION <i>servicing you with pride</i>	

CURB RAMP TYPES

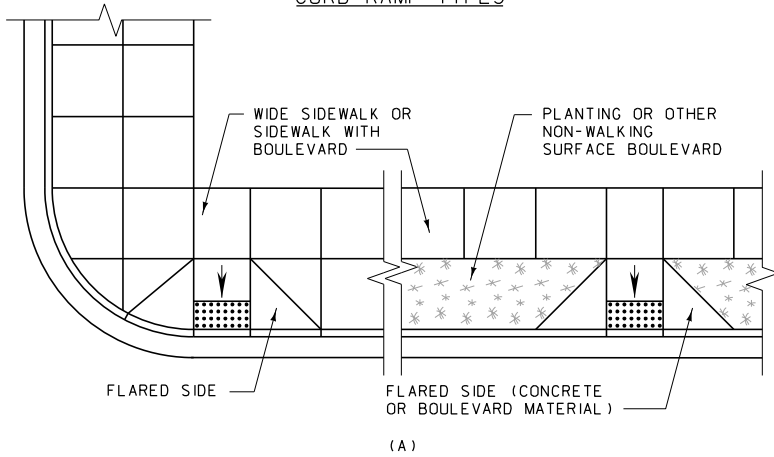

(A)
PERPENDICULAR PUBLIC SIDEWALK CURB RAMP
(SEE DETAILED DRAWING NUMBER 608-25 FOR
ADDITIONAL DETAILS)

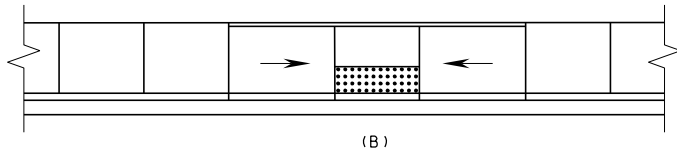

(B)
PARALLEL PUBLIC SIDEWALK CURB RAMP
(SEE DETAILED DRAWING NUMBER 608-30
FOR ADDITIONAL DETAILS)

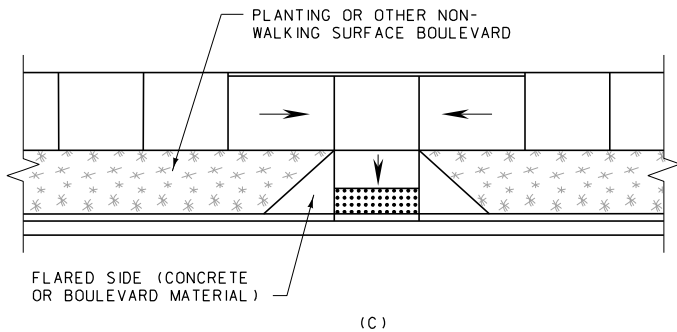

(C)
COMBINED (PARALLEL/PERPENDICULAR) PUBLIC
SIDEWALK CURB RAMP (SEE DETAILED DRAWING
NUMBERS 608-25 AND 608-30 FOR ADDITIONAL
DETAILS)

GENERAL NOTES:

1. IN NEW CONSTRUCTION, USE PUBLIC SIDEWALK CURB RAMP IN THE FOLLOWING ORDER OF PREFERENCE:
 - A. PERPENDICULAR PUBLIC SIDEWALK CURB RAMP.
 - B. PARALLEL PUBLIC SIDEWALK CURB RAMP.
 - C. COMBINED (PARALLEL/PERPENDICULAR) PUBLIC SIDEWALK CURB RAMP.
 - D. DIAGONAL PERPENDICULAR PUBLIC SIDEWALK CURB RAMP.
2. WHEN ALTERING EXISTING FACILITIES, MEET NEW CONSTRUCTION REQUIREMENTS FOR PUBLIC SIDEWALK CURB RAMP TO THE MAXIMUM EXTENT FEASIBLE.

SINGLE DIAGONAL OR DEPRESSED CORNER PUBLIC SIDEWALK CURB RAMP SERVING TWO STREET CROSSING DIRECTIONS ARE NOT PERMITTED IN NEW CONSTRUCTION.

3. IF POSSIBLE, DO NOT PLACE DRAINAGE STRUCTURES IN CONFLICT WITH PUBLIC SIDEWALK CURB RAMP. LOCATION OF CURB RAMP TAKES PRECEDENCE OVER LOCATION OF DRAINAGE STRUCTURES EXCEPT WHERE EXISTING DRAINAGE STRUCTURES ARE BEING UTILIZED.
4. USE THE FLATTEST SLOPES POSSIBLE FOR ALL CURB RAMP. MAXIMUM SLOPES ARE SHOWN FOR GUIDANCE AT DIFFICULT SITES.
5. FINAL FIELD LOCATION OF THE CURB RAMP WILL BE DETERMINED BY THE ENGINEER.
6. IF R/W DOES NOT PERMIT LANDINGS FOR THESE RAMP, USE ANOTHER RAMP DESIGN.
7. PEDESTRIAN ACCESS POINTS AT CROSSWALKS ARE TO BE WHOLLY CONTAINED WITHIN THE CROSSWALK LINES.
8. FOR ADDITIONAL INFORMATION CONSULT:

APPENDIX IV
AMERICANS WITH DISABILITIES ACT (ADA)
ACCESSIBILITY GUIDELINES FOR BUILDINGS AND
FACILITIES
AUGUST 1994 EDITION

CONSTRUCTION REQUIREMENTS:

1. OBTAIN A SURFACE TEXTURE ON THE RAMP BY COARSE BROOMING, TRANSVERSE TO THE RAMP SLOPE.
2. TAKE CARE DURING CONSTRUCTION TO ASSURE UNIFORM RAMP GRADES, FREE OF SAGS AND SHARP GRADE CHANGES.

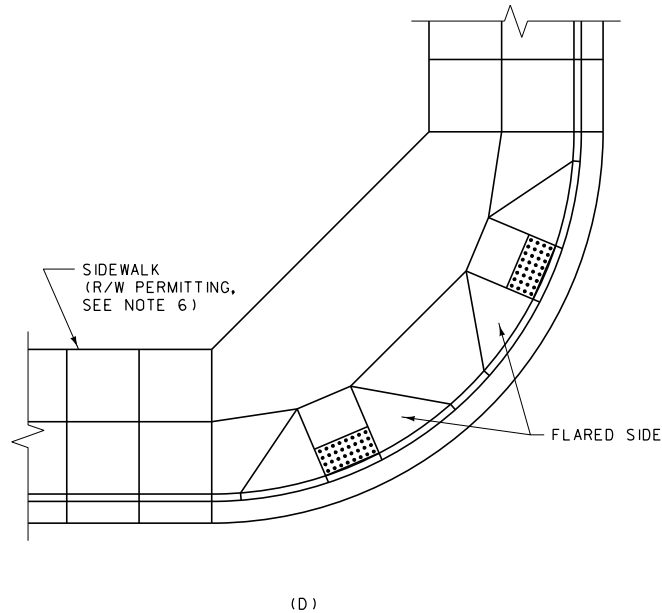

(D)
DIAGONAL PERPENDICULAR PUBLIC SIDEWALK
CURB RAMP (SEE DETAILED DRAWING NUMBER
608-35 FOR ADDITIONAL DETAILS)

DETAILED DRAWING	
REFERENCE STANDARD SPEC. SECTION 608	DWG. NO. 608-15
NEW CONSTRUCTION PUBLIC SIDEWALK CURB RAMP	
EFFECTIVE: FEBRUARY 2005	
 MONTANA DEPARTMENT OF TRANSPORTATION <i>-serving you with pride-</i>	

CURB RAMP TYPES

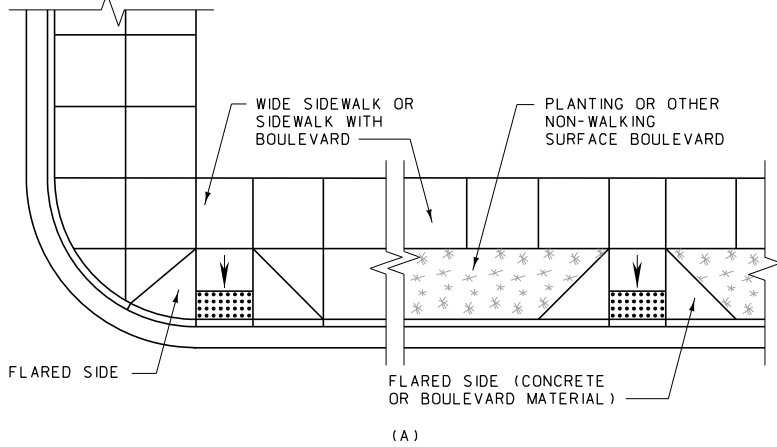

(A)
PERPENDICULAR PUBLIC SIDEWALK CURB RAMP
(SEE DETAILED DRAWING NUMBER 608-25 FOR ADDITIONAL DETAILS)

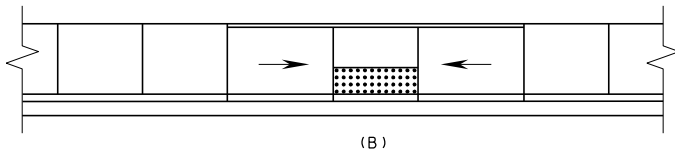

(B)
PARALLEL PUBLIC SIDEWALK CURB RAMP
(SEE DETAILED DRAWING NUMBER 608-30 FOR ADDITIONAL DETAILS)

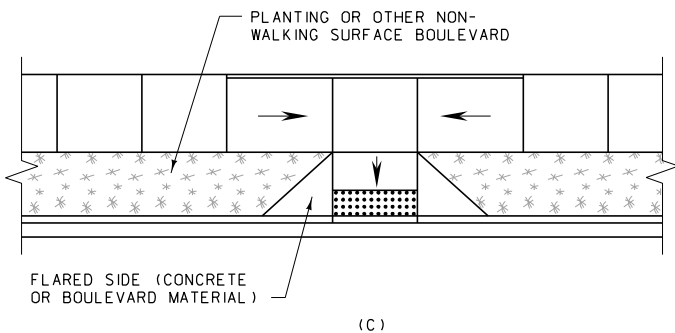

(C)
COMBINED (PARALLEL/PERPENDICULAR) PUBLIC SIDEWALK CURB RAMP (SEE DETAILED DRAWING NUMBERS 608-25 AND 608-30 FOR ADDITIONAL DETAILS)

CURB RAMP TYPES

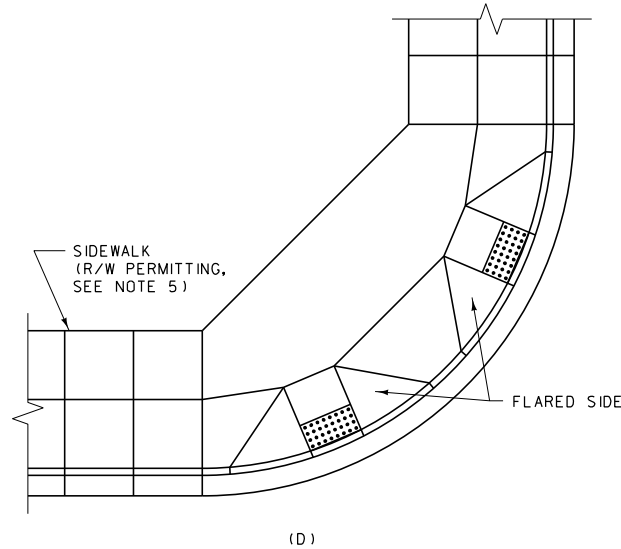

(D)
DIAGONAL PERPENDICULAR PUBLIC SIDEWALK CURB RAMP (SEE DETAILED DRAWING NUMBER 608-35 FOR ADDITIONAL DETAILS)

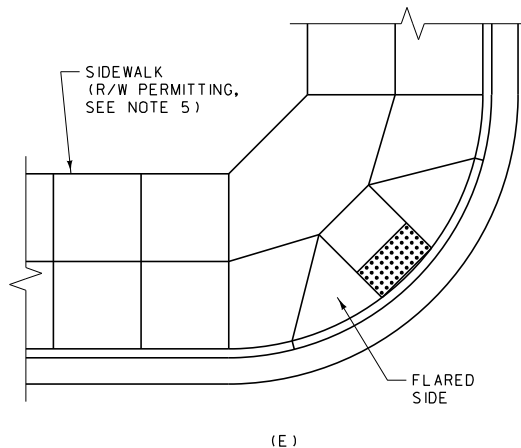

(E)
SINGLE DIAGONAL PERPENDICULAR PUBLIC SIDEWALK CURB RAMP (SEE DETAILED DRAWING NUMBER 608-35 FOR ADDITIONAL DETAILS)

GENERAL NOTES:

1. WHEN ALTERING EXISTING FACILITIES, USE PUBLIC SIDEWALK CURB RAMP IN THE FOLLOWING ORDER OF PREFERENCE:
 - A. PERPENDICULAR PUBLIC SIDEWALK CURB RAMP
 - B. PARALLEL PUBLIC SIDEWALK CURB RAMP
 - C. COMBINED (PARALLEL/PERPENDICULAR) PUBLIC SIDEWALK CURB RAMP
 - D. DIAGONAL PERPENDICULAR PUBLIC SIDEWALK CURB RAMP
 - E. SINGLE DIAGONAL PERPENDICULAR PUBLIC SIDEWALK CURB RAMP

NOTE: USE DIAGONAL PUBLIC SIDEWALK CURB RAMP AS THE LAST OPTION AND CONSTRUCT TO COMPLY WITH ALL ADA SLOPE AND CONSTRUCTION CRITERIA TO THE GREATEST EXTENT POSSIBLE.

2. PLACE CURB RAMP TO AVOID EXISTING DRAINAGE STRUCTURES AND OTHER OBSTRUCTIONS TO THE GREATEST EXTENT POSSIBLE.
3. USE THE FLATTEST SLOPES POSSIBLE FOR ALL CURB RAMP. MAXIMUM SLOPES ARE SHOWN FOR GUIDANCE AT DIFFICULT SITES AND SHOULD BE AVOIDED IF POSSIBLE.
4. FINAL FIELD LOCATION OF THE CURB RAMP WILL BE DETERMINED BY THE ENGINEER.
5. IF R/W DOES NOT PERMIT LANDINGS FOR THESE RAMP, USE ANOTHER RAMP DESIGN.
6. PEDESTRIAN ACCESS POINTS AT CROSSWALKS ARE TO BE WHOLLY CONTAINED WITHIN THE CROSSWALK LINES.
7. FOR ADDITIONAL INFORMATION CONSULT:

APPENDIX IV
AMERICANS WITH DISABILITIES ACT (ADA)
ACCESSIBILITY GUIDELINES FOR BUILDINGS
AND FACILITIES
AUGUST, 1994 EDITION

CONSTRUCTION REQUIREMENTS:

1. OBTAIN A SURFACE TEXTURE ON THE RAMP BY COARSE BROOMING, TRANSVERSE TO THE RAMP SLOPE.
2. TAKE CARE DURING CONSTRUCTION TO ASSURE UNIFORM RAMP GRADES, FREE OF SAGS AND SHARP GRADE CHANGES.

DETAILED DRAWING	
REFERENCE STANDARD SPEC. SECTION 608	DWG. NO. 608-20
ALTERATIONS TO EXISTING FACILITIES - PUBLIC SIDEWALK CURB RAMP	
EFFECTIVE: FEBRUARY 2005	
 MONTANA DEPARTMENT OF TRANSPORTATION <i>-serving you with pride-</i>	

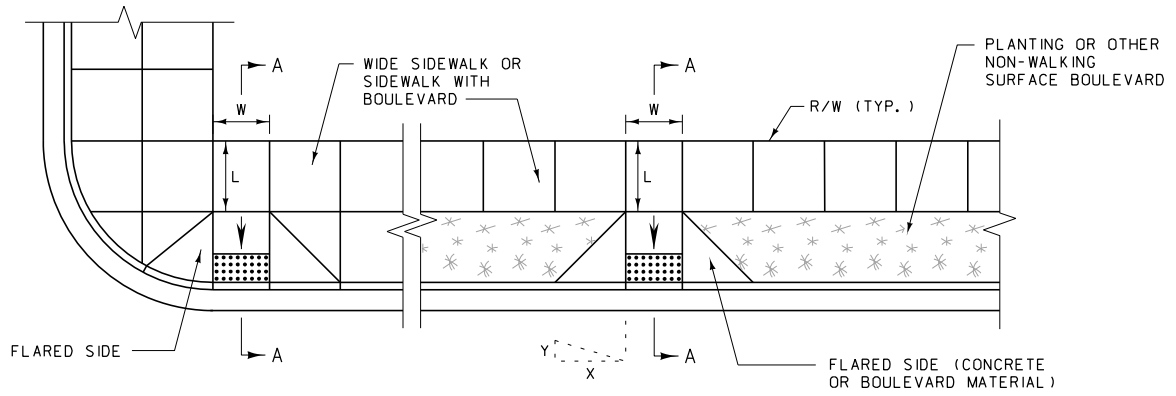

PERPENDICULAR PUBLIC SIDEWALK CURB RAMP

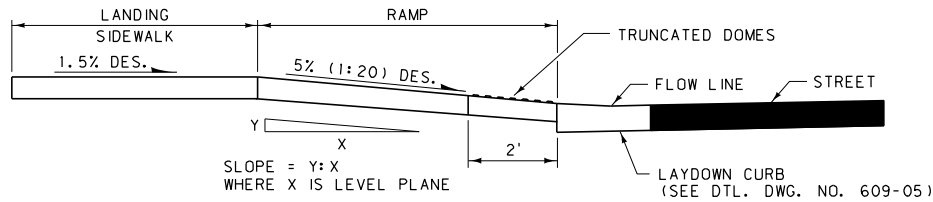

SECTION A-A

NEW CONSTRUCTION REQUIREMENTS:

1. THE DESIRABLE WIDTH OF THE CURB RAMP (DIMENSION "W" ABOVE) IS 4 FEET OR WIDER. THE MINIMUM WIDTH ("W") IS 3 FEET.
2. THE DESIRABLE LENGTH OF THE LANDING AT THE TOP OF THE CURB RAMP (DIMENSION "L" ABOVE) IS 5 FEET. THE MINIMUM LENGTH "L" IS 4 FEET. THE LANDING WIDTH IS EQUAL TO THE RAMP WIDTH.
3. THE DESIRABLE SLOPE FOR THE CURB RAMP IS 5% (1:20) OR FLATTER. THE MAXIMUM CURB RAMP SLOPE IS 8.3% (1:12).
4. THE DESIRABLE SLOPE FOR THE FLARED SIDE OF THE CURB RAMP IS 8.3% (1:12) OR FLATTER. THE MAXIMUM FLARED SIDE SLOPE IS 10% (1:10).
5. THE DESIRABLE CROSS SLOPE OF THE SIDEWALK, RAMP, OR LANDING IS 1.5% (1:66.7). THE MAXIMUM CROSS SLOPE OF THE SIDEWALK, RAMP, OR LANDING IS 2% (1:50).
6. PROVIDE TRUNCATED DOMES ON THE BOTTOM 2 FEET OF EACH RAMP AS SHOWN ABOVE. SEE DETAILED DRAWING NUMBER 608-40 FOR TRUNCATED DOMES DETAILS.

REQUIREMENTS FOR ALTERATIONS TO EXISTING FACILITIES:

NOTE: WHEREVER POSSIBLE, ALTER EXISTING FACILITIES TO COMPLY WITH THE NEW CONSTRUCTION REQUIREMENTS.

1. THE MINIMUM WIDTH OF THE CURB RAMP (DIMENSION "W" ABOVE) IS 3 FEET.
2. WHERE PUBLIC PEDESTRIAN RIGHT-OF-WAY WIDTH IS INSUFFICIENT TO ACCOMMODATE A TOP LANDING OF 4 FEET, PROVIDE A TOP LANDING OF 3 FEET. THE LANDING WIDTH IS EQUAL TO THE RAMP WIDTH.
NOTE: IF EXISTING RIGHT-OF-WAY OR OTHER OBSTRUCTIONS REDUCE THE LANDING LENGTH TO LESS THAN 4 FEET, THE MAXIMUM FLARED SIDE SLOPE IS 8.3% (1:12).
3. THE MAXIMUM CURB RAMP SLOPE IS 10% (1:10), PROVIDED THE RISE (DIMENSION "Y" ABOVE) IS 6 INCHES OR LESS. AN 8.3% (1:12) OR FLATTER SLOPE IS DESIRABLE.
4. THE MAXIMUM FLARED SIDE SLOPE IS 10% (1:10).
5. THE DESIRABLE CROSS SLOPE OF THE SIDEWALK, RAMP, OR LANDING IS 1.5% (1:66.7). THE MAXIMUM CROSS SLOPE OF THE SIDEWALK, RAMP, OR LANDING IS 2% (1:50).
6. PROVIDE TRUNCATED DOMES ON THE BOTTOM 2 FEET OF EACH RAMP AS SHOWN ABOVE. SEE DETAILED DRAWING NUMBER 608-40 FOR TRUNCATED DOMES DETAILS.
7. WHERE EXISTING SITE DEVELOPMENT CONDITIONS PROHIBIT THE STRICT AND FULL COMPLIANCE OF ALL ADA CRITERIA, PROVIDE ACCESSIBILITY TO THE MAXIMUM EXTENT FEASIBLE.

GENERAL NOTES:

1. WHERE THE PUBLIC PEDESTRIAN RIGHT-OF-WAY WILL NOT ACCOMMODATE A PERPENDICULAR PUBLIC SIDEWALK CURB RAMP AND LANDING MEETING THESE REQUIREMENTS, USE A COMBINED (PARALLEL/PERPENDICULAR) OR PARALLEL PUBLIC SIDEWALK CURB RAMP.
2. COMBINED (PARALLEL/PERPENDICULAR) PUBLIC SIDEWALK CURB RAMPS ARE TO MEET THE CRITERIA FOR BOTH THE PARALLEL AND PERPENDICULAR PUBLIC SIDEWALK CURB RAMPS. (SEE DETAILED DRAWING NUMBER 608-30 AND THIS DRAWING.)

DETAILED DRAWING	
REFERENCE STANDARD SPEC. SECTION 608	DWG. NO. 608-25
PERPENDICULAR PUBLIC SIDEWALK CURB RAMPS	
EFFECTIVE: FEBRUARY 2005	
 MONTANA DEPARTMENT OF TRANSPORTATION <i>servicing you with pride</i>	

PARALLEL PUBLIC SIDEWALK CURB RAMPS

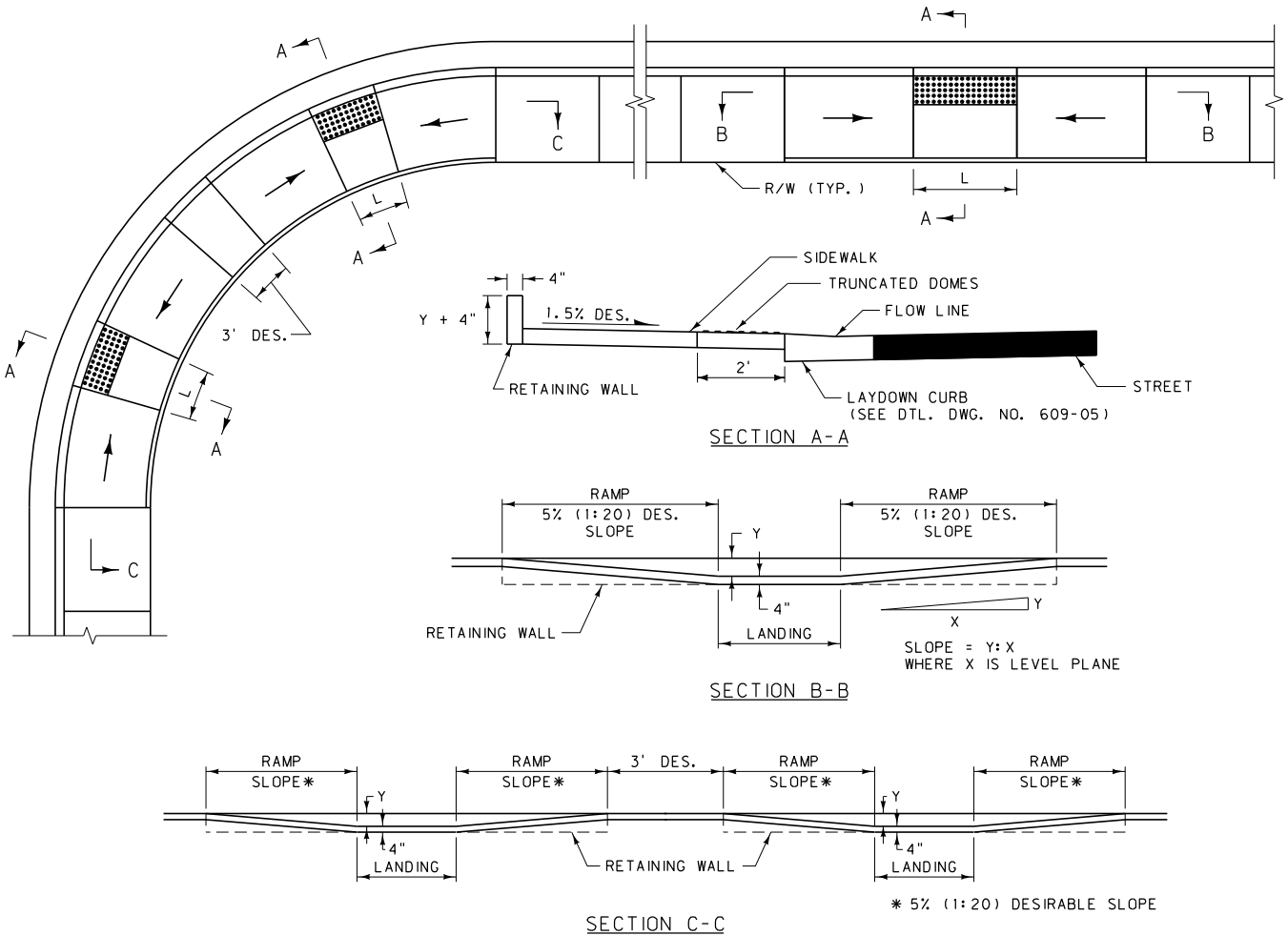

NEW CONSTRUCTION REQUIREMENTS:

1. THE MINIMUM LENGTH OF THE LANDING (DIMENSION "L" ABOVE) IS 5 FEET.
2. THE DESIRABLE SLOPE FOR THE CURB RAMPS IS 5% (1:20) OR FLATTER. THE MAXIMUM CURB RAMP SLOPE IS 8.3% (1:12).
3. THE DESIRABLE CROSS SLOPE OF THE SIDEWALK, RAMP, OR LANDING IS 1.5% (1:66.7). THE MAXIMUM CROSS SLOPE OF THE SIDEWALK, RAMP, OR LANDING IS 2% (1:50).
4. PROVIDE TRUNCATED DOMES ON THE BOTTOM 2 FEET OF EACH LANDING AS SHOWN ABOVE. SEE DETAIL DRAWING NUMBER 608-40 FOR TRUNCATED DOMES DETAILS.

REQUIREMENTS FOR ALTERATIONS TO EXISTING FACILITIES:

NOTE: WHEREVER POSSIBLE, ALTER EXISTING FACILITIES TO COMPLY WITH THE NEW CONSTRUCTION REQUIREMENTS.

1. THE DESIRABLE LENGTH OF THE LANDING (DIMENSION "L" ABOVE) IS 5 FEET. THE MINIMUM LANDING LENGTH IS 4 FEET.
2. THE MAXIMUM CURB RAMP SLOPE IS 10% (1:10), PROVIDED THE RISE (DIMENSION "Y" ABOVE) IS 6 INCHES OR LESS. AN 8.3% (1:12) OR FLATTER SLOPE IS DESIRABLE.
3. THE DESIRABLE CROSS SLOPE OF THE SIDEWALK, RAMP, OR LANDING IS 1.5% (1:66.7). THE MAXIMUM CROSS SLOPE OF THE SIDEWALK, RAMP, OR LANDING IS 2% (1:50).
4. PROVIDE TRUNCATED DOMES ON THE BOTTOM 2 FEET OF EACH LANDING AS SHOWN ABOVE. SEE DETAILED DRAWING NUMBER 608-40 FOR TRUNCATED DOMES DETAILS.
5. WHERE EXISTING SITE DEVELOPMENT CONDITIONS PROHIBIT THE STRICT AND FULL COMPLIANCE OF ALL ADA CRITERIA, PROVIDE ACCESSIBILITY TO THE MAXIMUM EXTENT FEASIBLE.

GENERAL NOTES:

1. THE COST OF THE RETAINING WALL IS INCLUDED IN THE UNIT PRICE BID FOR CONCRETE SIDEWALK.
2. COMBINED (PARALLEL/PERPENDICULAR) PUBLIC SIDEWALK CURB RAMPS ARE TO MEET THE CRITERIA FOR BOTH THE PARALLEL AND PERPENDICULAR PUBLIC SIDEWALK CURB RAMPS. (SEE DETAILED DRAWING NUMBER 608-25 AND THIS DRAWING.)

DETAILED DRAWING	
REFERENCE STANDARD SPEC. SECTION 608	DWG. NO. 608-30
PARALLEL PUBLIC SIDEWALK CURB RAMPS	
EFFECTIVE: FEBRUARY 2005	
 MONTANA DEPARTMENT OF TRANSPORTATION <i>servicing you with pride</i>	

DIAGONAL PERPENDICULAR PUBLIC SIDEWALK CURB RAMP

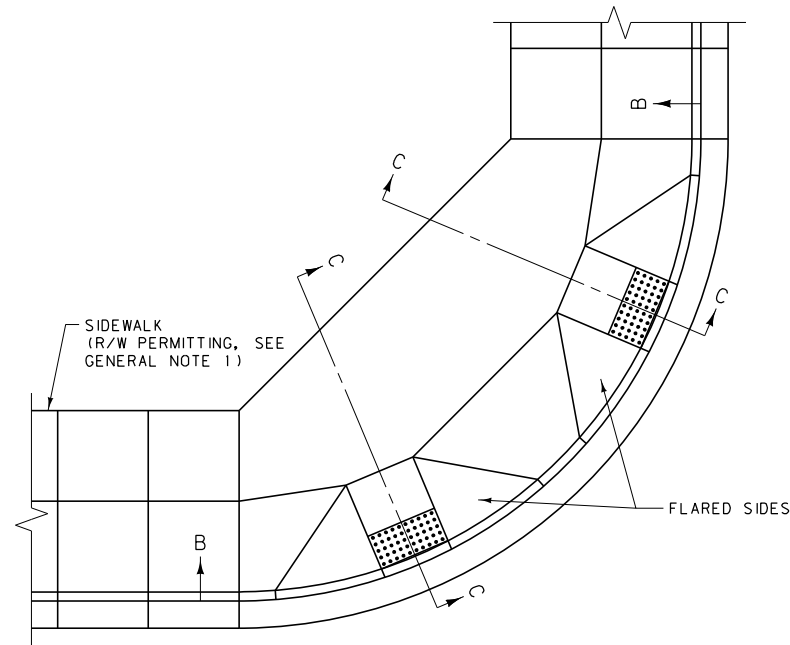

SINGLE DIAGONAL PERPENDICULAR PUBLIC SIDEWALK CURB RAMP

NOTE: SINGLE DIAGONAL PERPENDICULAR PUBLIC SIDEWALK CURB RAMPS SERVING TWO STREET CROSSING DIRECTIONS ARE NOT PERMITTED IN NEW CONSTRUCTION.

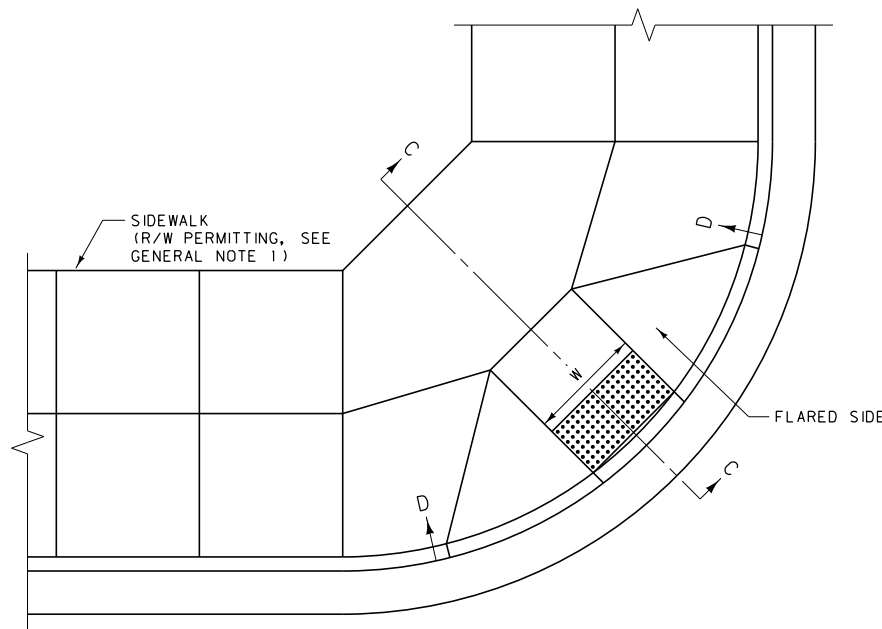

PRIVATE APPROACH SIDEWALK CURB RAMP

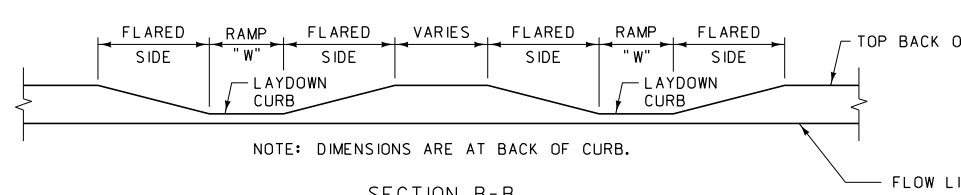
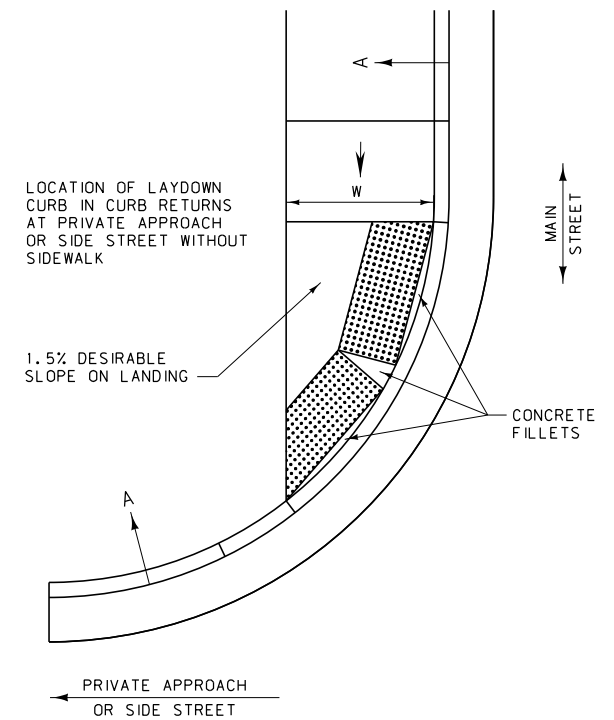

SECTION B-B

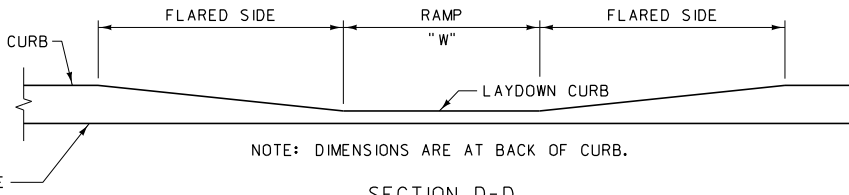

SECTION D-D

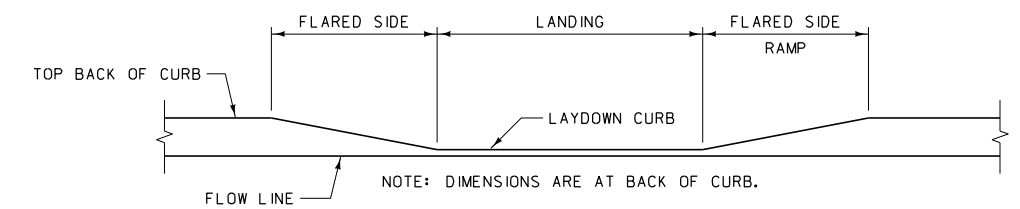

SECTION A-A

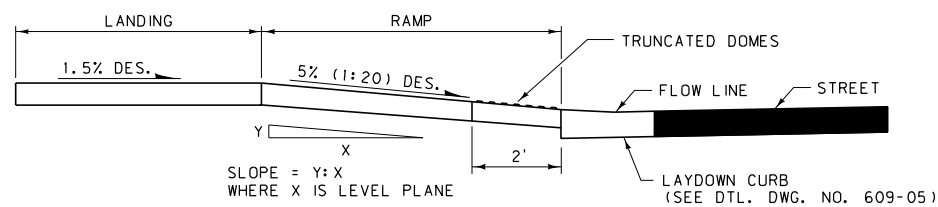

SECTION C-C

NEW CONSTRUCTION REQUIREMENTS:

1. THE DESIRABLE WIDTH OF THE CURB RAMP (DIMENSION "W" ABOVE) IS 4 FEET OR WIDER. THE MINIMUM WIDTH ("W") IS 3 FEET.
2. THE DESIRABLE LENGTH OF THE LANDING AT THE TOP OF THE CURB RAMP (DIMENSION "L" ABOVE) IS 5 FEET. THE MINIMUM LENGTH "L" IS 4 FEET. THE LANDING WIDTH IS EQUAL TO THE RAMP WIDTH.
3. THE DESIRABLE SLOPE FOR THE CURB RAMP IS 5% (1:20) OR FLATTER. THE MAXIMUM CURB RAMP SLOPE IS 8.3% (1:12).
4. THE DESIRABLE SLOPE FOR THE FLARED SIDE OF THE CURB RAMP IS 8.3% (1:12) OR FLATTER. THE MAXIMUM FLARED SIDE SLOPE IS 10% (1:10).
5. THE DESIRABLE CROSS SLOPE OF THE SIDEWALK, RAMP, OR LANDING IS 1.5% (1:66.7). THE MAXIMUM CROSS SLOPE OF THE SIDEWALK, RAMP, OR LANDING IS 2% (1:50).
6. PROVIDE TRUNCATED DOMES ON THE BOTTOM 2 FEET OF EACH RAMP AS SHOWN ABOVE. SEE DETAILED DRAWING NUMBER 608-40 FOR TRUNCATED DOMES DETAILS.

REQUIREMENTS FOR ALTERATIONS TO EXISTING FACILITIES:

NOTE: WHEREVER POSSIBLE, ALTER EXISTING FACILITIES TO COMPLY WITH THE NEW CONSTRUCTION REQUIREMENTS.

1. THE MINIMUM WIDTH OF THE CURB RAMP (DIMENSION "W" ABOVE) IS 3 FEET.
2. WHERE PUBLIC PEDESTRIAN RIGHT-OF-WAY WIDTH IS INSUFFICIENT TO ACCOMMODATE A TOP LANDING OF 4 FEET, PROVIDE A TOP LANDING OF 3 FEET. THE LANDING WIDTH IS EQUAL TO THE RAMP WIDTH.
NOTE: IF EXISTING RIGHT-OF-WAY OR OTHER OBSTRUCTIONS REDUCE THE LANDING LENGTH TO LESS THAN 4 FEET, THE MAXIMUM FLARED SIDE SLOPE IS 8.3% (1:12).
3. THE MAXIMUM CURB RAMP SLOPE IS 10% (1:10), PROVIDED THE RISE (DIMENSION "Y" ABOVE) IS 6 INCHES OR LESS. AN 8.3% (1:12) OR FLATTER SLOPE IS DESIRABLE.
4. THE MAXIMUM FLARED SIDE SLOPE IS 10% (1:10).
5. THE DESIRABLE CROSS SLOPE OF THE SIDEWALK, RAMP, OR LANDING IS 1.5% (1:66.7). THE MAXIMUM CROSS SLOPE OF THE SIDEWALK, RAMP, OR LANDING IS 2% (1:50).
6. PROVIDE TRUNCATED DOMES ON THE BOTTOM 2 FEET OF EACH RAMP AS SHOWN ABOVE. SEE DETAILED DRAWING NUMBER 608-40 FOR TRUNCATED DOMES DETAILS.
7. WHERE EXISTING SITE DEVELOPMENT CONDITIONS PROHIBIT THE STRICT AND FULL COMPLIANCE OF ALL ADA CRITERIA, PROVIDE ACCESSIBILITY TO THE MAXIMUM EXTENT FEASIBLE.

GENERAL NOTES:

1. WHERE THE PUBLIC PEDESTRIAN RIGHT-OF-WAY WILL NOT ACCOMMODATE A DIAGONAL PERPENDICULAR PUBLIC SIDEWALK CURB RAMP AND LANDING MEETING THESE REQUIREMENTS, USE ANOTHER RAMP DESIGN.
2. TRIM PRECAST TRUNCATED DOME PANELS TO FIT ON PRIVATE APPROACH SIDEWALK CURB RAMPS AS SHOWN ABOVE.

DETAILED DRAWING	
REFERENCE STANDARD SPEC. SECTION 608	DWG. NO. 608-35
DIAGONAL PERPENDICULAR PUBLIC SIDEWALK CURB RAMPS	
EFFECTIVE: FEBRUARY 2005	
 MONTANA DEPARTMENT OF TRANSPORTATION	

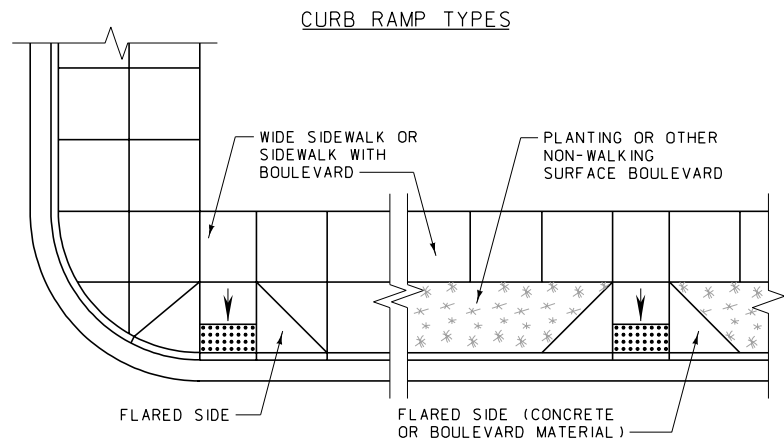

PERPENDICULAR PUBLIC SIDEWALK CURB RAMP
(SEE DETAILED DRAWING NUMBER 608-25 FOR
ADDITIONAL DETAILS)

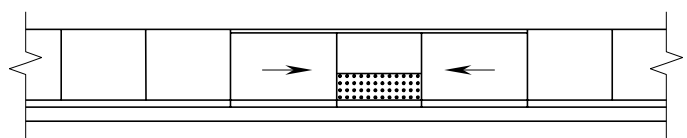

PARALLEL PUBLIC SIDEWALK CURB RAMP
(SEE DETAILED DRAWING NUMBER 608-30
FOR ADDITIONAL DETAILS)

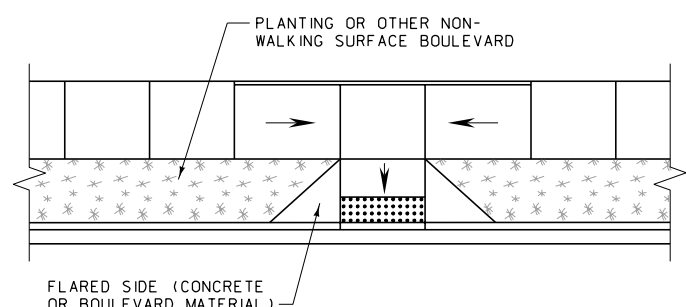

COMBINED (PARALLEL/PERPENDICULAR) PUBLIC
SIDEWALK CURB RAMP (SEE DETAILED DRAWING
NUMBERS 608-25 AND 608-30 FOR ADDITIONAL
DETAILS)

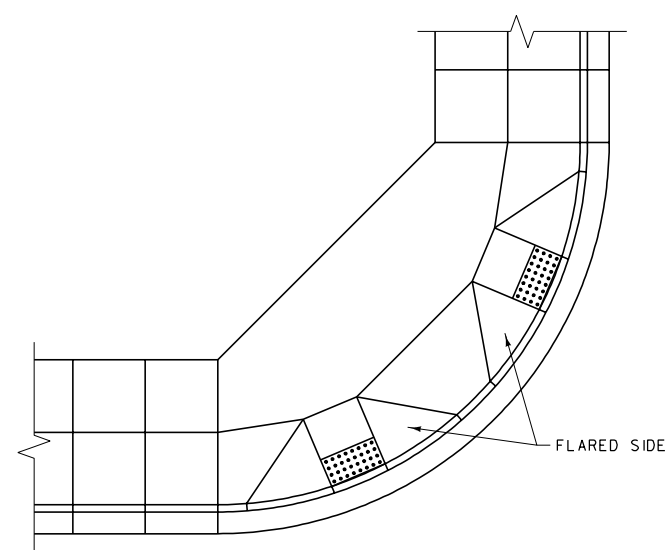
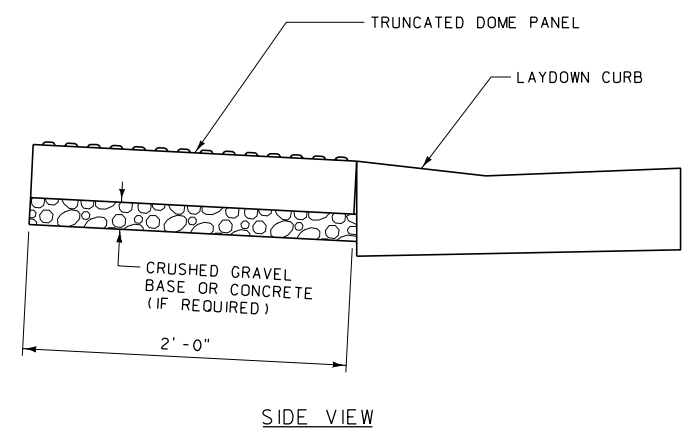

DIAGONAL PERPENDICULAR PUBLIC SIDEWALK
CURB RAMP (SEE DETAILED DRAWING NUMBER
608-35 FOR ADDITIONAL DETAILS)

TRUNCATED DOMES ALIGNMENT AND PATTERN

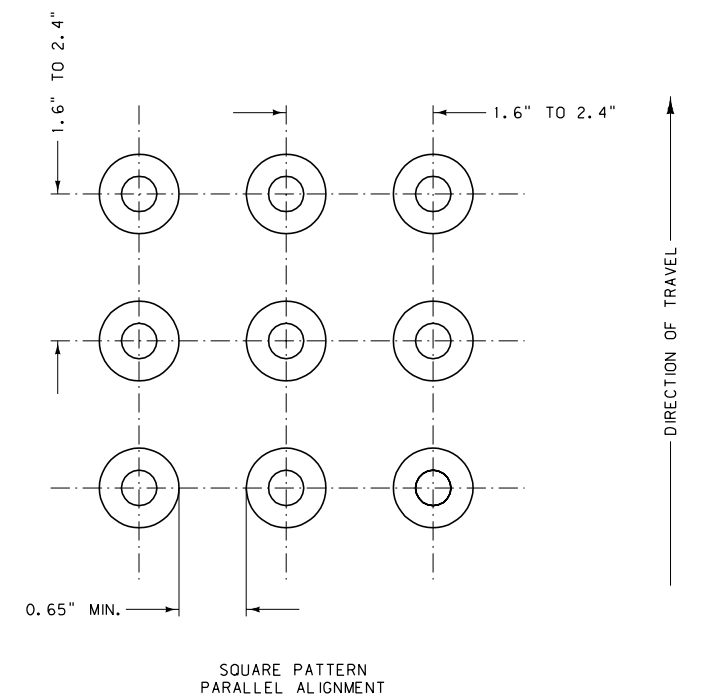

DOMES PROFILE

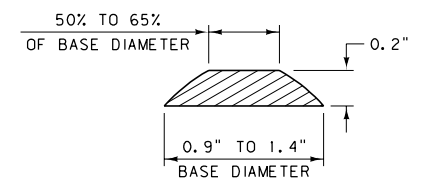

CONSTRUCTION REQUIREMENTS:

1. USE ONLY DETECTABLE WARNING DEVICES (ALSO KNOWN AS TRUNCATED DOMES) THAT ARE ON THE DEPARTMENT'S QUALIFIED PRODUCTS LIST.
2. USE DETECTABLE WARNING DEVICES THAT ARE A BRICK RED COLOR.
3. INSTALL DETECTABLE WARNING DEVICES THAT EXTEND THE FULL WIDTH OF THE RAMP, 2 FEET IN DEPTH.
4. INSTALL THE DOME PANEL ADJACENT TO THE BACK OF CURB. IF THE PANEL IS OFFSET, LOCATE THE EDGE OF THE PANEL NO MORE THAN 6 INCHES FROM THE BACK OF CURB.
5. IF THE DETECTABLE WARNING DEVICE IS EMBEDDED IN CONCRETE, INSTALL SO THE TOP OF THE PANEL IS FLUSH WITH THE ADJACENT CONCRETE AND THE DOMES WILL PROTRUDE ABOVE THE ADJACENT SURFACE.
6. ENSURE A UNIFORM GRADE ON THE DETECTABLE WARNING DEVICES FREE OF SAGS AND IRREGULAR SURFACES.

DETAILED DRAWING	
REFERENCE STANDARD SPEC. SECTION 608	DWG. NO. 608-40

DETECTABLE WARNING DEVICES