

CONNECTIONS

ARCH PIPE

ROUND PIPE

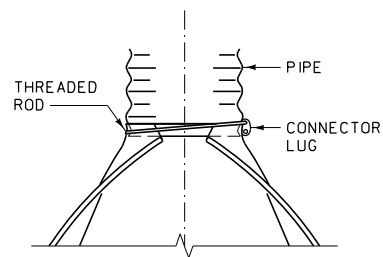

TYPE 1

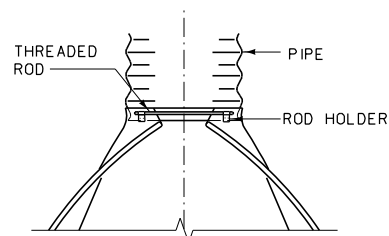

TYPE 2

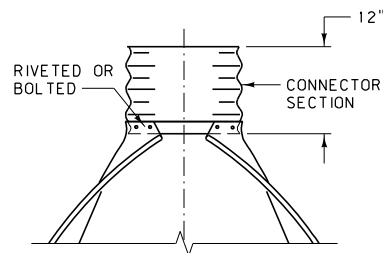

TYPE 3

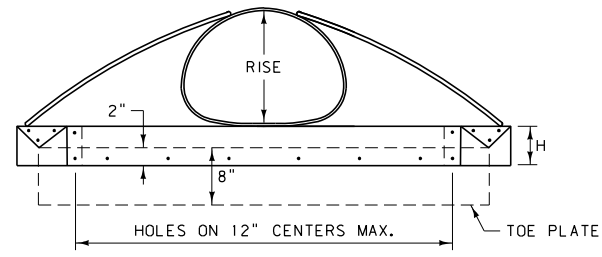

ELEVATION

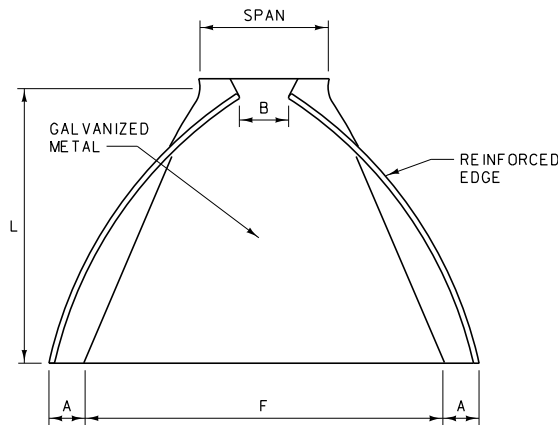

PLAN

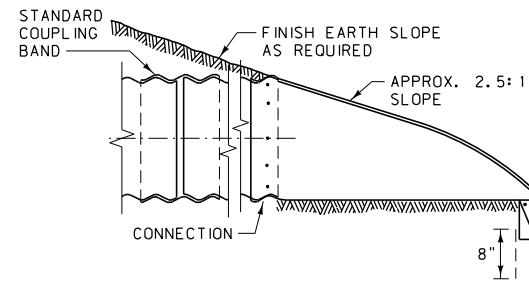

TYPICAL CROSS-SECTION
(ILLUSTRATED WITH TYPE 3 CONNECTION)

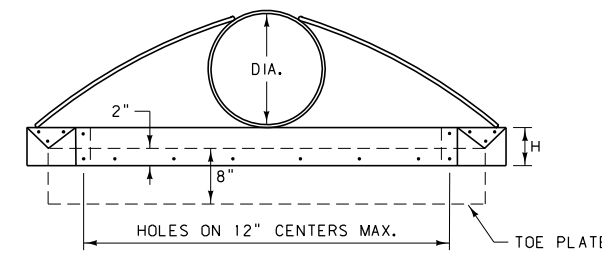

ELEVATION

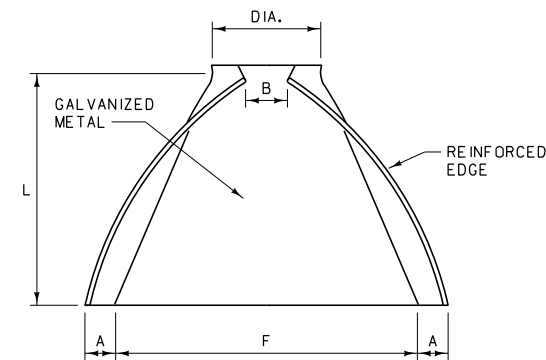

PLAN

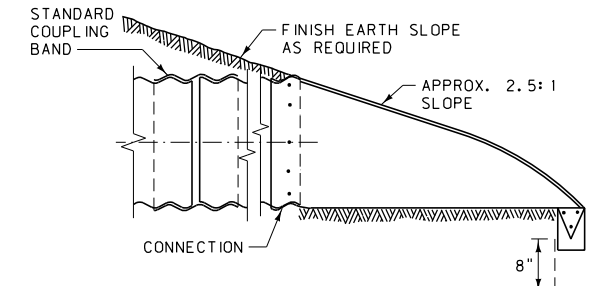

TYPICAL CROSS-SECTION
(ILLUSTRATED WITH TYPE 3 CONNECTION)

3" x 1" CORR. SPAN x RISE	MINIMUM THICKNESS	2 2/3" x 1/2" CORR. SPAN x RISE	MINIMUM THICKNESS	DIMENSIONS					TYPE CONNECTOR
				A 1" TOL.	B MAX.	H 1" TOL.	L 1 1/2" TOL.	F 2" TOL.	
		17" x 13"	0.064"	7"	9"	6"	19"	30"	2
		21" x 15"	0.064"	7"	10"	6"	23"	30"	2
		24" x 18"	0.064"	8"	12"	6"	28"	42"	2
		28" x 20"	0.064"	9"	14"	6"	32"	48"	2
		35" x 24"	0.079"	10"	16"	6"	39"	60"	2
40" x 31"	0.079"	42" x 29"	0.079"	12"	18"	8"	46"	75"	3
46" x 36"	0.109"	49" x 33"	0.109"	13"	21"	9"	53"	85"	3
53" x 41"	0.109"	57" x 38"	0.109"	18"	26"	12"	63"	90"	3
60" x 46"	0.109"	64" x 43"	0.109"	18"	30"	12"	70"	102"	3
66" x 51"	0.109"	71" x 47"	0.109"	18"	33"	12"	77"	114"	3
73" x 55"	0.109"	77" x 52"	0.109"	18"	36"	12"	77"	126"	3
81" x 59"	0.109"	83" x 57"	0.109"	18"	36"	12"	77"	138"	3

PIPE DIA.	MINIMUM THICKNESS	DIMENSIONS					TYPE CONNECTOR
		A 1" TOL.	B MAX.	H 1" TOL.	L 1 1/2" TOL.	F 2" TOL.	
12"	0.064"	6"	6"	6"	21"	24"	1
15"	0.064"	7"	8"	6"	26"	30"	1
18"	0.064"	8"	10"	6"	31"	36"	1
21"	0.064"	9"	12"	6"	36"	42"	1
24"	0.064"	10"	13"	6"	41"	48"	1
30"	0.079"	12"	16"	8"	51"	60"	2
36"	0.079"	14"	19"	9"	60"	72"	2
42"	0.109"	16"	22"	11"	69"	84"	3
48"	0.109"	18"	27"	12"	78"	90"	3
54"	0.109"	18"	30"	12"	84"	102"	3
60"	0.109"	18"	33"	12"	87"	114"	3
66"	0.109"	18"	36"	12"	87"	120"	3
72"	0.109"	18"	39"	12"	87"	126"	3
78"	0.109"	18"	42"	12"	87"	132"	3
84"	0.109"	18"	45"	12"	87"	138"	3

NOTES:
 PROVIDE TOE PLATE WHEN SPECIFIED.
 GALVANIZE ALL PARTS IN ACCORDANCE WITH AASHTO M 36.
 PAINT ANY AREAS WHERE GALVANIZING IS BROKEN OR METAL IS BARE WITH ONE COAT OF ZINC CHROMATE PRIME AND TWO COATS OF ALUMINUM PAINT.
 MINOR VARIATIONS IN DESIGN MAY BE ACCEPTABLE ON APPROVAL OF THE ENGINEER.
 SEAMS OR JOINTS LENGTHWISE OF THE APRON ARE ACCEPTABLE IF SECURELY BOLTED OR WELDED AND PAINTED AS PROVIDED ABOVE.

DETAILED DRAWING
 REFERENCE DWG. NO.
 STANDARD SPEC. 603-02
 SECTION 603, 709
 CMP FLARED END
 TERMINAL SECTION
 (FETS)
 EFFECTIVE: FEBRUARY 2005
 MONTANA DEPARTMENT OF TRANSPORTATION
servicing you with pride

TYPE "A"

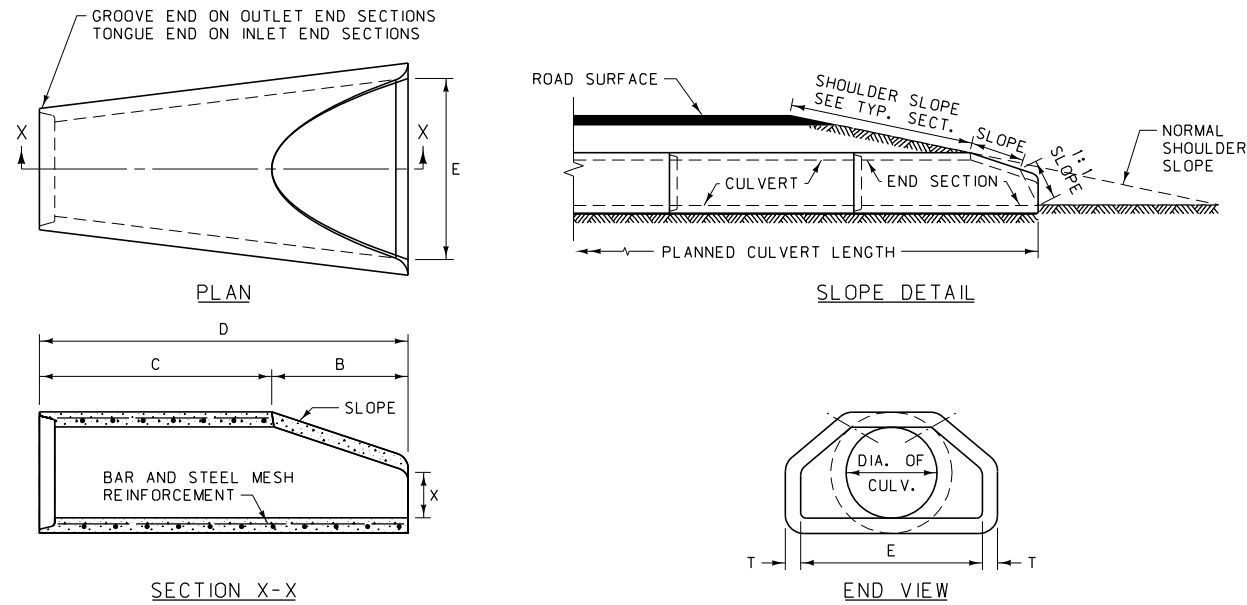

TYPE "A"							
DIA.	SLOPE	X	B	C	D	E	T *
12"	2.4:1	4"	2'-0"	4'-0"	6'-0"	2'-0"	2"
15"	2.4:1	6"	2'-3"	3'-9"	6'-0"	2'-6"	2 1/4"
18"	2.3:1	9"	2'-3"	3'-9"	6'-0"	3'-0"	2 1/2"
24"	2.5:1	9 1/2"	3'-7 1/2"	2'-4 1/2"	6'-0"	4'-0"	3"
30"	2.5:1	1'-0"	4'-6"	1'-6"	6'-0"	5'-0"	3 1/2"
36"	2.5:1	1'-3"	5'-3"	2'-11"	8'-2"	6'-0"	4"
42"	2.5:1	1'-9"	5'-3"	2'-11"	8'-2"	6'-6"	4 1/2"
48"	2.5:1	2'-0"	6'-0"	2'-2"	8'-2"	7'-0"	5"
54"	2.0:1	2'-3"	5'-5"	2'-9 1/2"	8'-2 1/2"	7'-6"	5 1/2"

* WALL "B" THICKNESS

TOLERANCES IN THE ADJACENT TABLES MAY NOT VARY MORE THAN ±1.5% FOR THE DIMENSIONS SHOWN. OTHERWISE THEY MUST CONFORM TO AASHTO M 170.

TYPE "B"

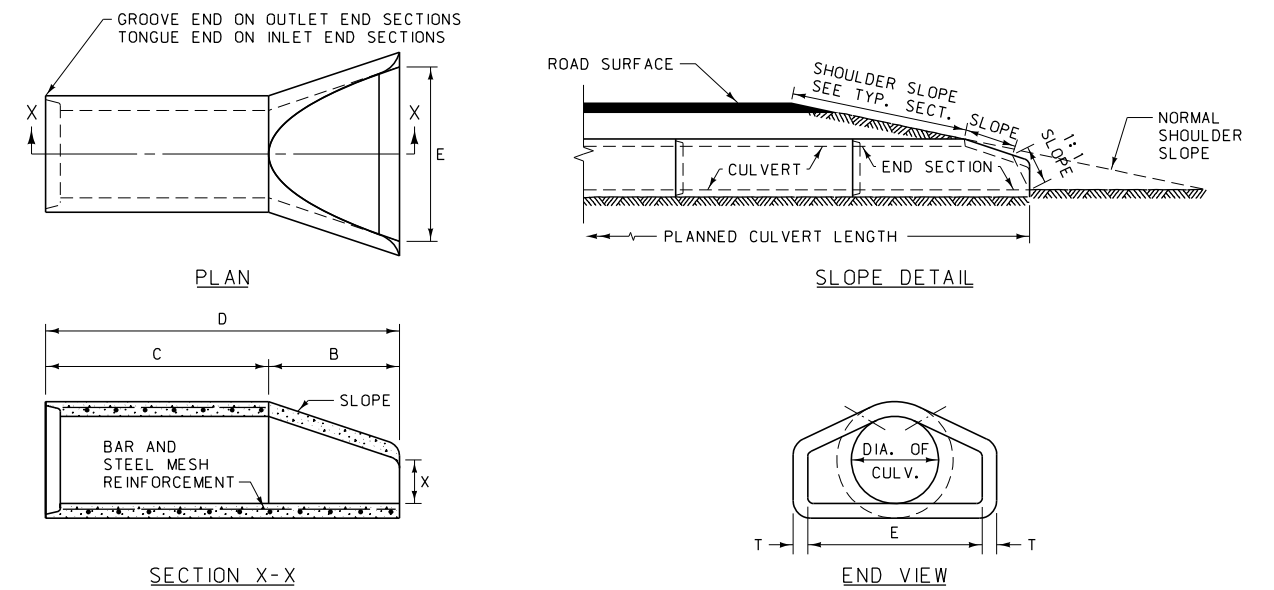

TYPE "B"							
DIA.	SLOPE	X	B	C	D	E	T *
12"	2.4:1	4"	2'-0"	4'-0"	6'-0"	2'-0"	2"
15"	2.4:1	6"	2'-3"	3'-9"	6'-0"	2'-6"	2 1/4"
18"	2.3:1	9"	2'-3"	3'-9"	6'-0"	3'-0"	2 1/2"
24"	2.5:1	9 1/2"	3'-7 1/2"	2'-4 1/2"	6'-0"	4'-0"	3"
30"	2.5:1	1'-0"	4'-6"	1'-6"	6'-0"	5'-0"	3 1/2"
36"	2.5:1	1'-3"	5'-3"	2'-11"	8'-2"	6'-0"	4"
42"	2.5:1	1'-9"	5'-3"	2'-11"	8'-2"	6'-6"	4 1/2"
48"	2.5:1	2'-0"	6'-0"	2'-2"	8'-2"	7'-0"	5"
54"	2.0:1	2'-3"	5'-5"	2'-9 1/2"	8'-2 1/2"	7'-6"	5 1/2"

* WALL "B" THICKNESS

LARGE DIAMETER PIPE

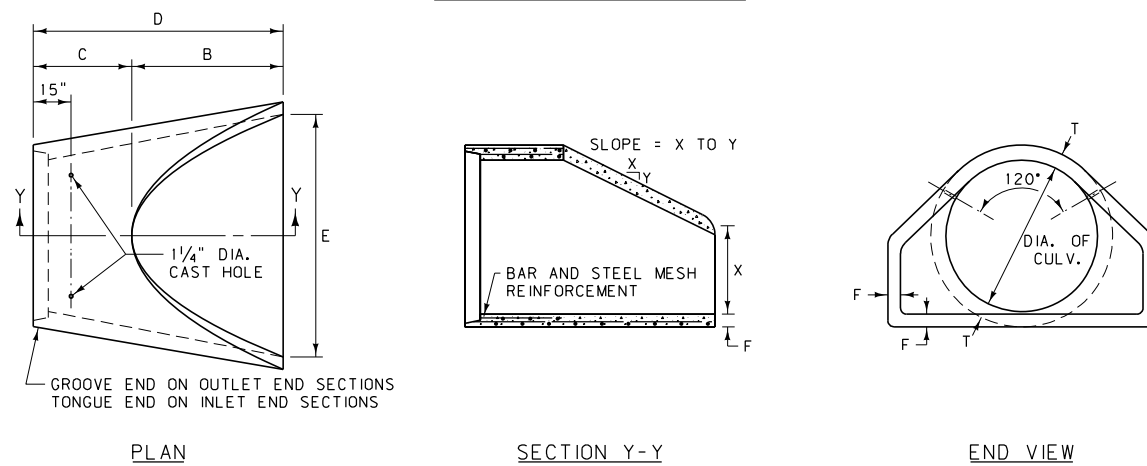

LARGE DIAMETER CULVERT								
DIA.	SLOPE	T *	X	B	C	D	E	F
60"	1.9:1	6"	2'-11"	5'-0"	3'-3"	8'-3"	8'-0"	5"
66"	1.7:1	6 1/2"	2'-6"	6'-0"	2'-3"	8'-3"	8'-6"	5 1/2"
72"	1.9:1	7"	3'-0"	6'-6"	1'-9"	8'-3"	9'-0"	6"
78"	1.8:1	7 1/2"	3'-0"	7'-6"	1'-9"	9'-3"	9'-6"	6 1/2"
84"	1.5:1	8"	3'-0"	7'-6 1/2"	1'-9"	9'-3 1/2"	10'-0"	6 1/2"
90"	1.5:1	8 1/2"	3'-5"	7'-3 1/2"	2'-0"	9'-3 1/2"	11'-0"	6 1/2"

* WALL "B" THICKNESS

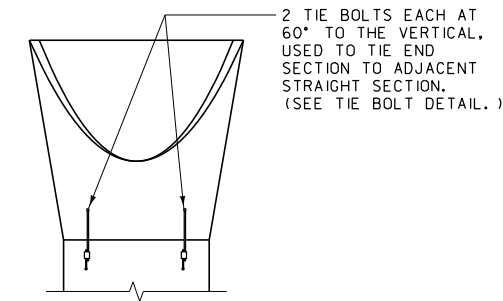

TIE BOLT CONNECTION

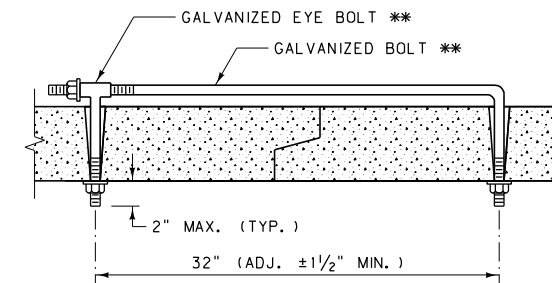

TIE BOLT DETAIL
(TWO PER END SECTION)

TIE BOLTS: USE TWO TIE BOLTS ON ALL FLARED END SECTIONS, ONE ON EACH SIDE AT 60° TO THE VERTICAL. GALVANIZE ALL PARTS. SEE TIE BOLT DETAIL.

CONSTRUCTION: CONSTRUCT ACCORDING TO CLASS III, AASHTO M 170, AS FAR AS DESIGN WILL PERMIT.

DETAILED DRAWING	
REFERENCE STANDARD SPEC. SECTION 603, 708	DWG. NO. 603-08
PREFABRICATED RCP FLARED END TERMINAL SECTION (FETS)	

-- REVISED --
January 2008

EFFECTIVE: FEBRUARY 2005
MONTANA DEPARTMENT OF TRANSPORTATION
serving you with pride

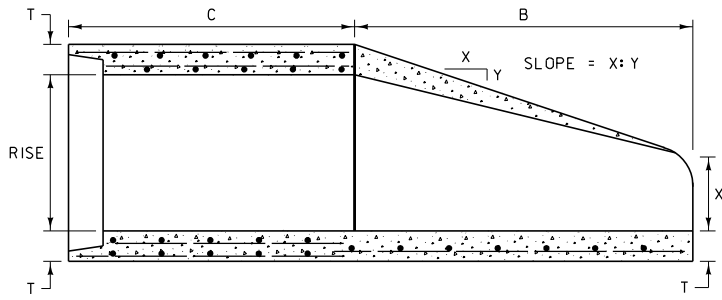

LONGITUDINAL SECTION

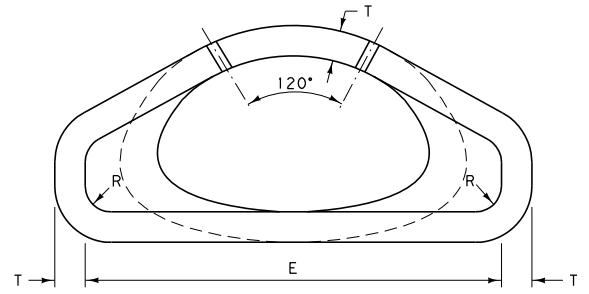

END VIEW

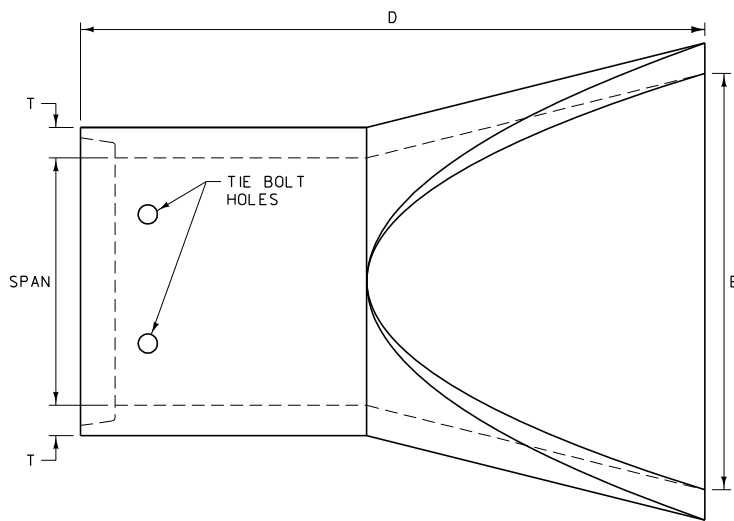

PLAN VIEW

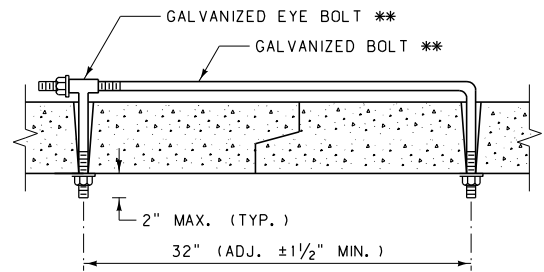

** 3/4" FOR 18" TO 54" EQUIV. SIZE
1" FOR 60" TO 72" EQUIV. SIZE

TIE BOLT DETAIL
(TWO PER END SECTION)

TIE BOLTS: USE TIE BOLTS ON ALL FLARED END SECTIONS, ONE ON EACH SIDE AT 60° TO THE VERTICAL. GALVANIZE ALL PARTS. SEE TIE BOLT DETAIL.

CONSTRUCTION: CONSTRUCT ACCORDING TO CLASS A-III, AASHTO M 206, AS FAR AS DESIGN WILL PERMIT.

EQUIV. SIZE	SPAN	RISE	T *	X	B	C	D	E	R	SLOPE
18"	22"	13 1/2"	2 1/2"	7"	27"	45"	72"	36"	3"	3:1
24"	28 1/2"	18"	3 1/2"	8 1/2"	39"	33"	72"	48"	3"	3:1
30"	36 1/4"	22 1/2"	4"	9 1/2"	50"	46"	96"	60"	3"	3:1
36"	43 3/4"	26 5/8"	4 1/2"	11 1/8"	60"	36"	96"	72"	6"	3:1
42"	51 1/8"	31 5/16"	4 1/2"	15 13/16"	60"	36"	96"	78"	6"	3:1
48"	58 1/2"	36"	5"	21"	60"	36"	96"	84"	6"	3:1
54"	65"	40"	5 1/2"	25 1/2"	60"	36"	96"	90"	6"	3:1
60"	73"	45"	6"	31"	60"	36"	96"	96"	6"	3:1
72"	88"	54"	7"	31"	60"	36"	96"	120"	6"	2:1
84"	102"	62"	8"	21 1/2"	84"	24"	108"	144"	6"	2:1

* WALL "B" THICKNESS

DETAILED DRAWING	
REFERENCE STANDARD SPEC. SECTION 603	DWG. NO. 603-10
PREFABRICATED RCP ARCH FLARED END TERMINAL SECTION (FETS)	
EFFECTIVE: FEBRUARY 2005	
 MONTANA DEPARTMENT OF TRANSPORTATION <i>servicing you with pride</i>	

ROAD APPROACH CULVERT END TREATMENT

QUANTITIES (FOR ESTIMATING ONLY)

DIA. A RCP	H PIPE LENGTH	F-64½" x 4⅛" FERRULE LOOP INSERT (EACH)	LENGTH 2½" DIA. SCHEDULE 40 GALV. PIPE	DIMENSIONS (FT.)						
				B	C	D	E	G	R	J
15"	4.75'	~	~	~	~	0.69	0.27	4.0	0.25	0.75
18"	6.5'	~	~	~	~	0.71	0.25	5.75	0.25	0.75
24"	10.0'	10	12.5'	0.5	2.0	0.75	0.21	9.25	0.25	0.75

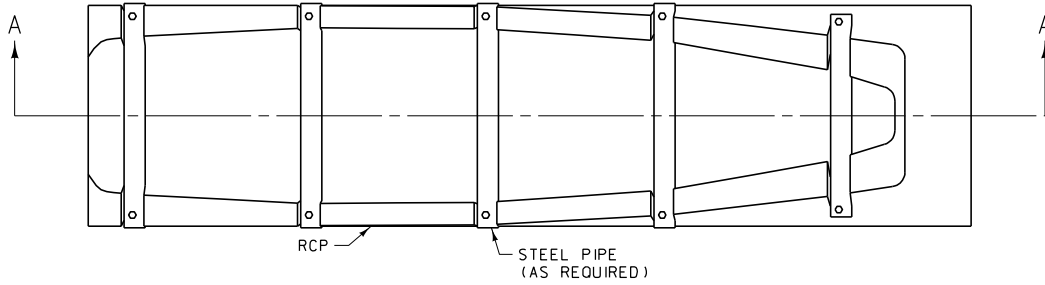

PLAN VIEW

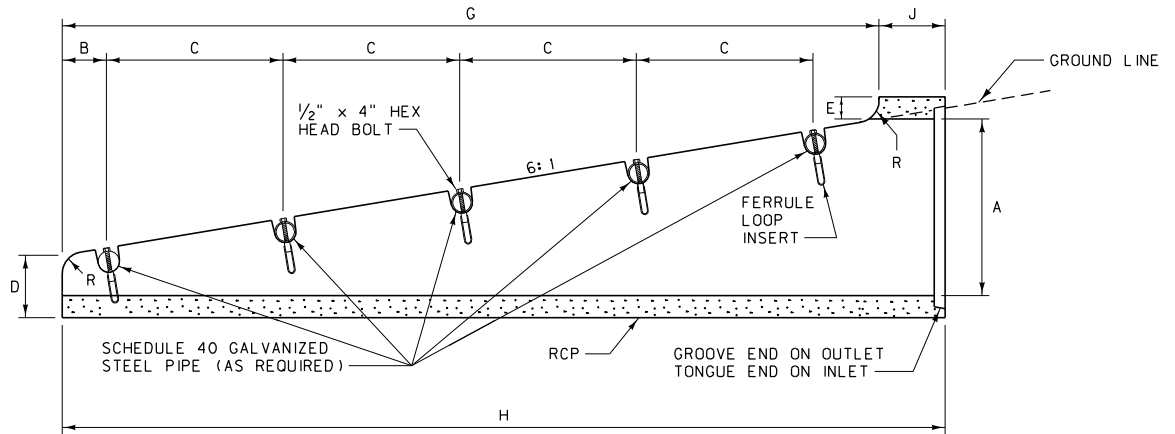

SECTION A-A

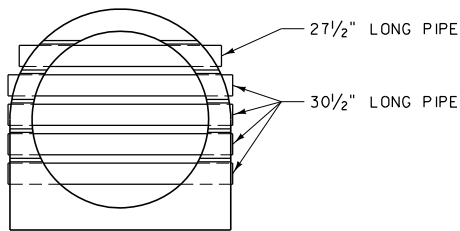

END VIEW

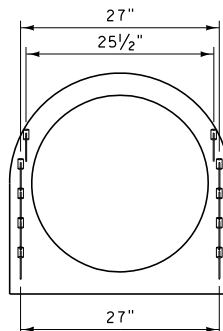

VIEW OF INSERTS

NOTE:
PAINT ALL NON-GALVANIZED PARTS
IN ACCORDANCE WITH SECTION 710
OF THE STANDARD SPECIFICATIONS.

DETAILED DRAWING	
REFERENCE STANDARD SPEC. SECTION 603, 710	DWG. NO. 603-12
RCP ROAD APPROACH CULVERT END TREATMENT (RACET)	

EFFECTIVE: FEBRUARY 2005

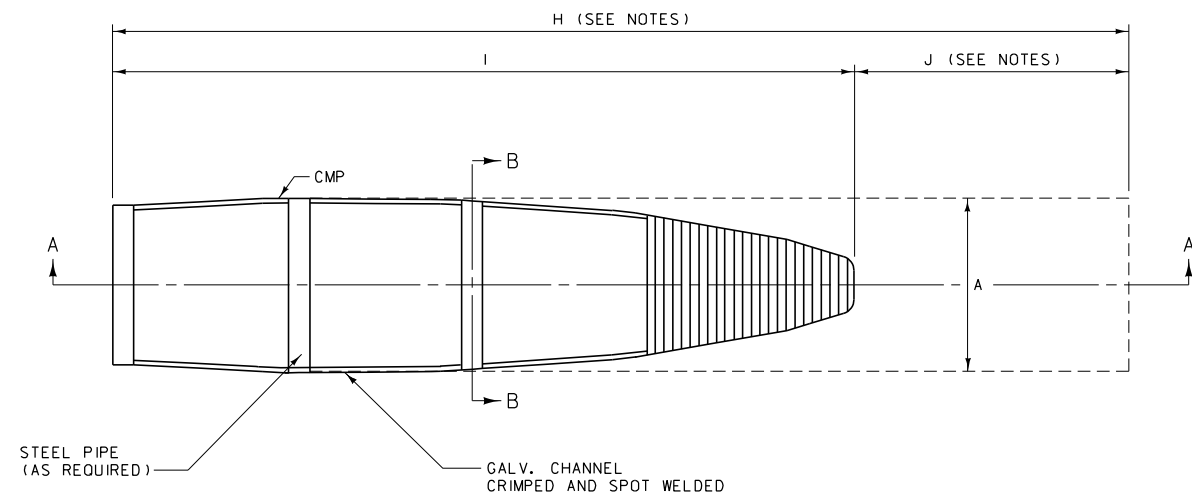

PLAN VIEW

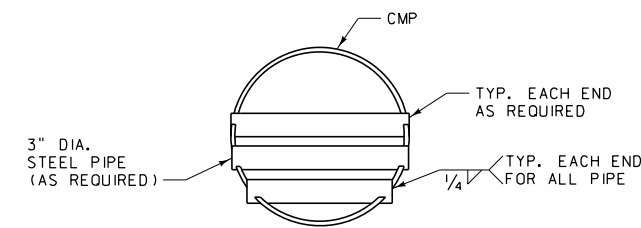

END VIEW

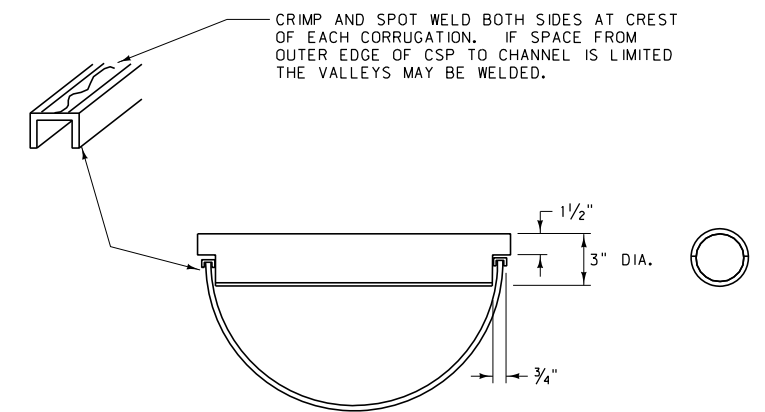

SECTION B-B

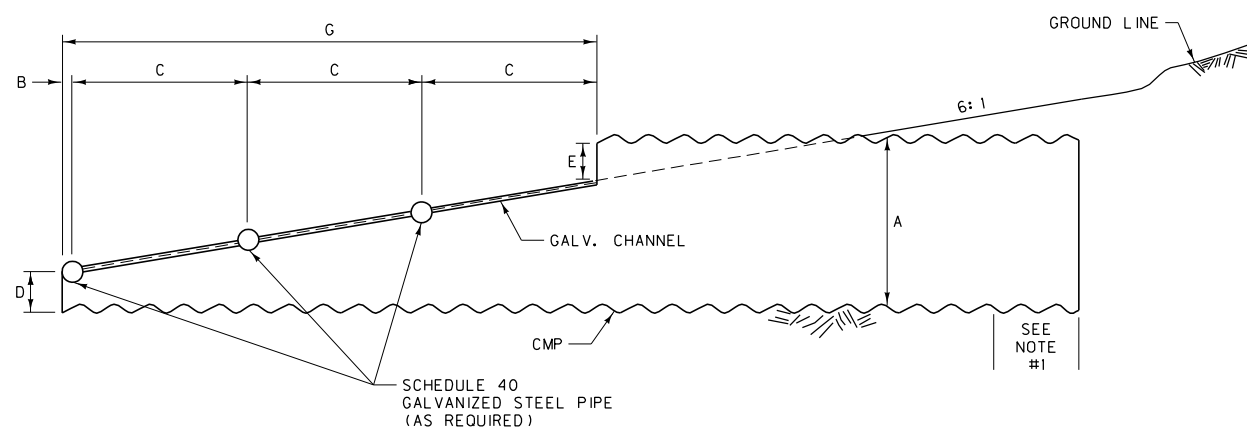

SECTION A-A

ILLUSTRATED WITH 24" CMP (30" CMP UTILIZES FOUR GALV. STEEL PIPES)

ROAD APPROACH CULVERT END TREATMENT										
QUANTITIES (FOR ESTIMATING ONLY)										
DIA. A CMP	H PIPE LENGTH	3/4" x 3/8" x 1/8" GALV. CHANNEL	LENGTH 3" DIA SCHEDULE 40 GALV. PIPE	DIMENSIONS (FT.)						
				B	C	D	E	G	I	J
15"	7.0'	10'	~	~	~	0.20	0.20	5.0	6.0	1.0
18"	8.0'	10'	~	~	~	0.33	0.33	5.0	7.0	1.0
24"	10.0'	12'	6.0'	0.15	1.95	0.50	0.50	6.0	9.0	1.0
30"	12.5'	16'	10.0'	0.20	1.95	0.60	0.60	8.0	11.5	1.0

NOTES:

- PIPE TO HAVE ANNULAR CORRUGATION OR REROLLED ENDS. USE ONLY APPROVED COUPLING BAND PER STANDARD SPECIFICATION 709.02 CMP. FOR RCP END TREATMENT, SEE DTL. DWG. NO. 603-26 FOR CONNECTION.
- THE TWO 3/4" CHANNELS MAY BE ELIMINATED FROM THE CULVERT END TREATMENT IF:
 - THE CULVERT IS FABRICATED WITH 12 GAGE (0.109" THICK) MATERIAL.
 - HALF CIRCLE NOTCHES ARE CUT IN THE CULVERT FOR THE STEEL PIPE WITH CONTINUOUS WELD OF THE PERIPHERY IN CONTACT PROVIDED.
 - ALL WELDS AND OTHER NON-GALVANIZED PARTS ARE PAINTED IN ACCORDANCE WITH STANDARD SPECIFICATIONS SECTION 710.
- CONNECTIONS MADE PER DTL. DWG. NO. 603-26 REQUIRE PIPE LENGTHS H AND J TO BE INCREASED BY 3".

DETAILED DRAWING	
REFERENCE STANDARD SPEC. SECTION 603, 709, 710	DWG. NO. 603-14
CMP ROAD APPROACH CULVERT END TREATMENT (RACET)	
EFFECTIVE: FEBRUARY 2005	
 serving you with pride	MONTANA DEPARTMENT OF TRANSPORTATION

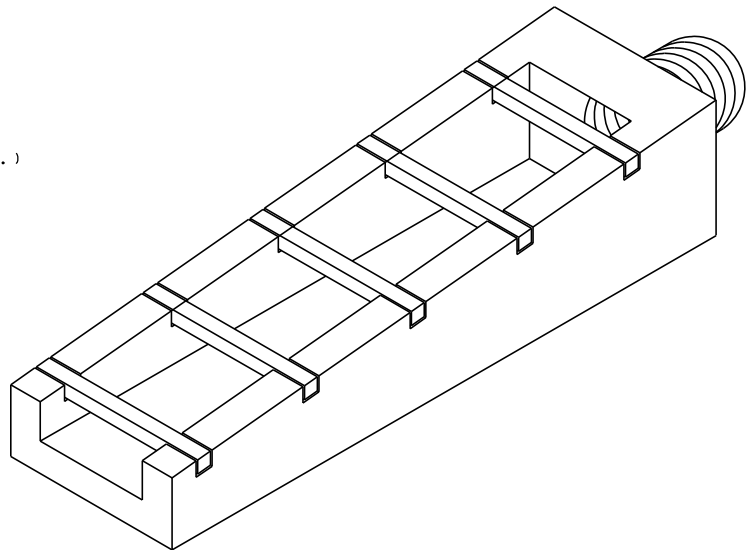
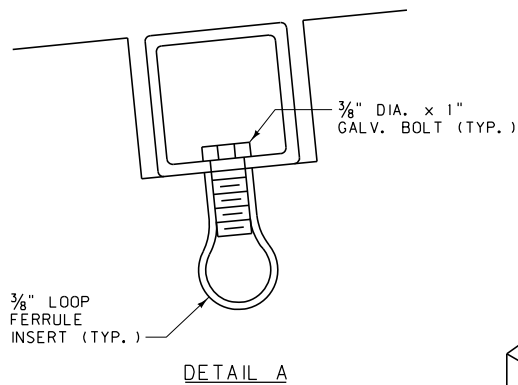
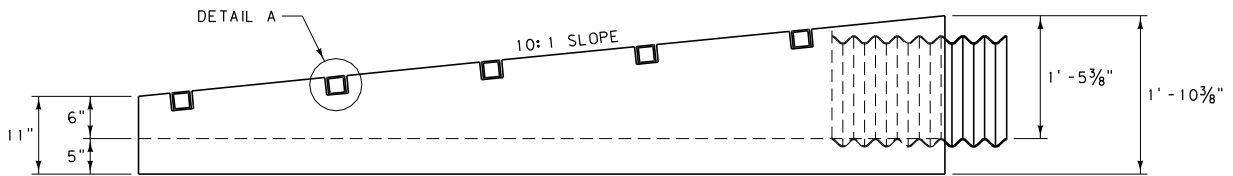
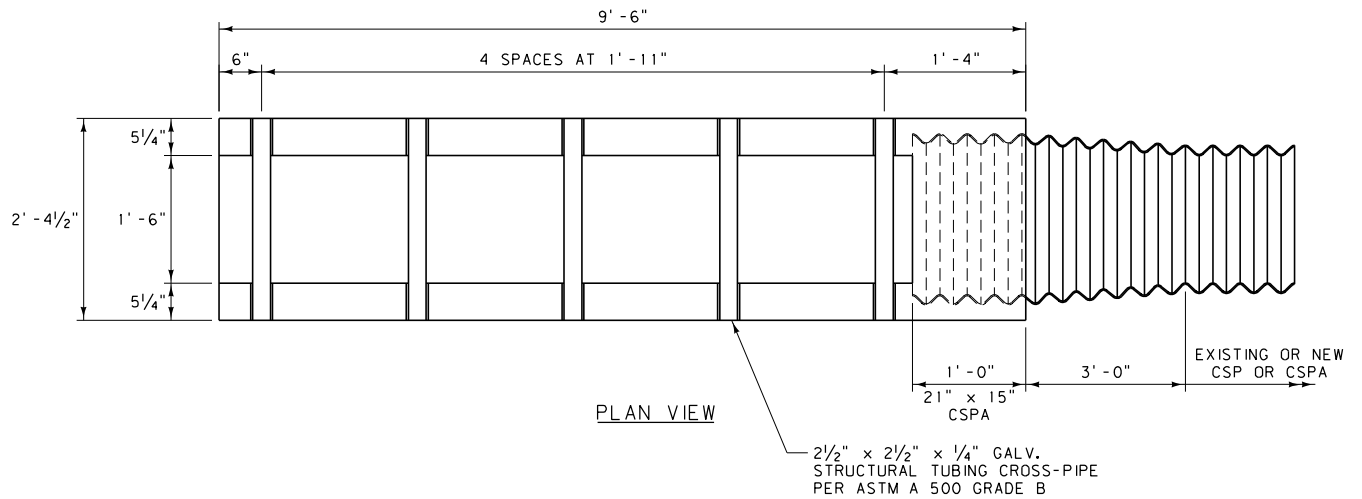

NOTE:
 PAINT ALL EXPOSED METAL PARTS WITH ONE COAT OF ZINC RICH PAINT AND TWO COATS OF ALUMINUM PAINT ACCORDING TO STANDARD SPECIFICATION SECTION 710.

DETAILED DRAWING	
REFERENCE STANDARD SPEC. SECTION 603, 708, 710	DWG. NO. 603-17
PRECAST MEDIAN U-TURN CROSS DRAIN AND CONC. BEVELED END	
EFFECTIVE: FEBRUARY 2005	
 MONTANA DEPARTMENT OF TRANSPORTATION <i>servicing you with pride</i>	

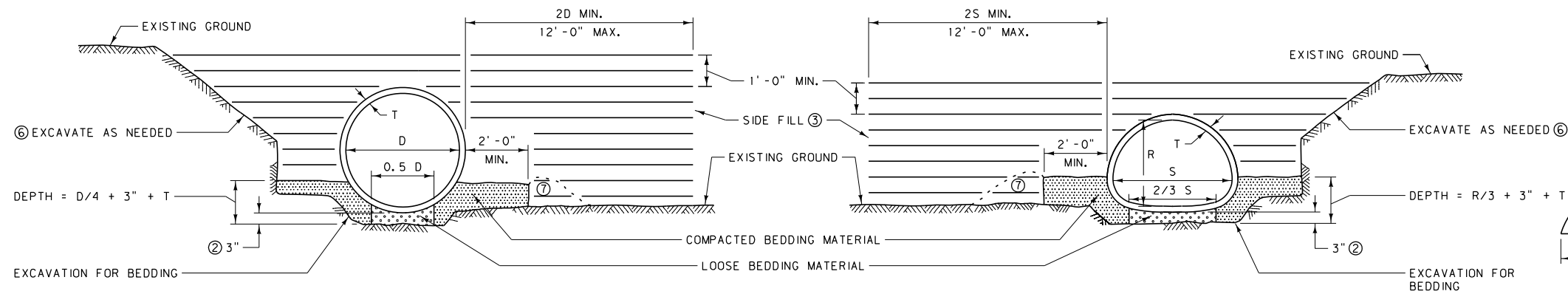

1-STANDARD BEDDING INSTALLATION

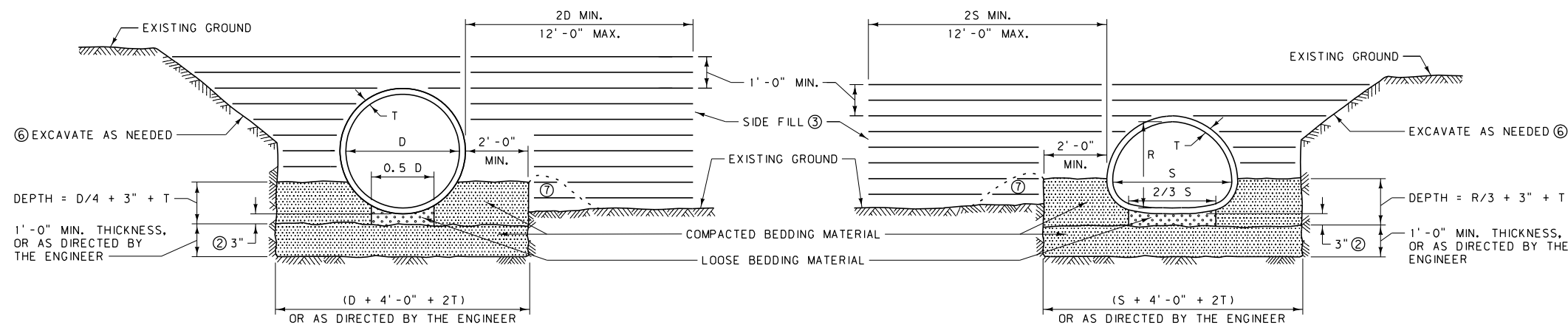
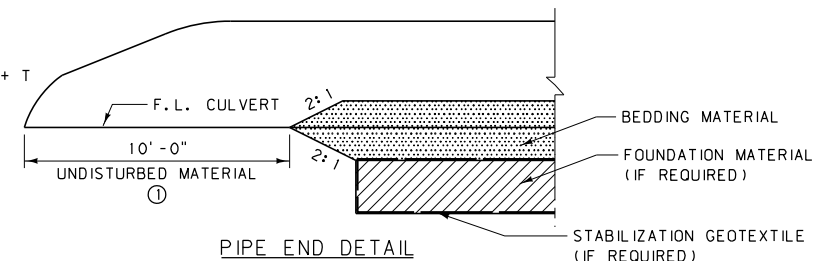

2-ROCK

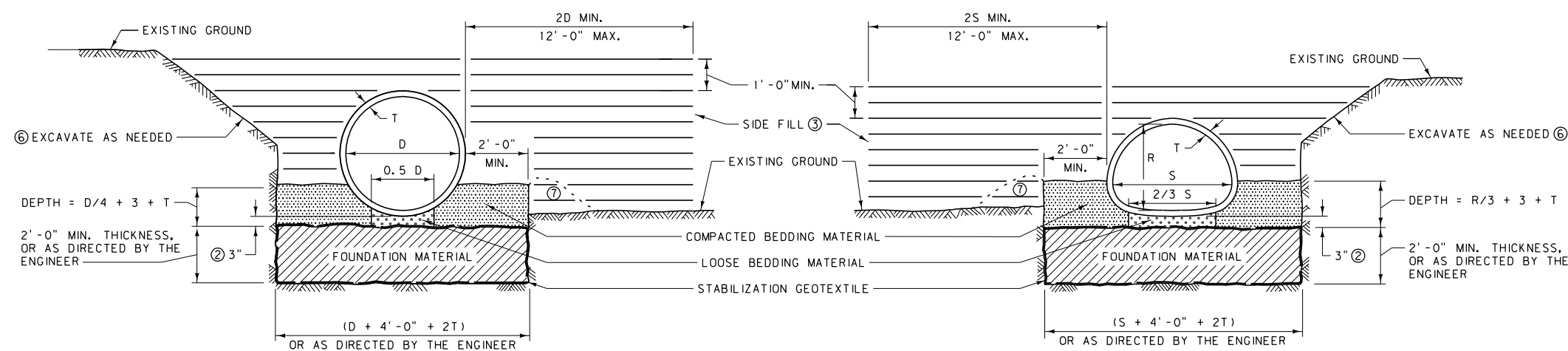

3-FOUNDATION STABILIZATION

NOTES:

- ① DO NOT EXTEND BEDDING MATERIAL TO THE END OF THE PIPE. LEAVE 10' OF UNDISTURBED MATERIAL AT EACH END UNLESS OTHERWISE NOTED IN PLANS. SEE PIPE END DETAIL.
- ② PLACE LOOSE BEDDING MATERIAL UNIFORMLY IN THE BOTTOM OF THE TRENCH AND SHAPE TO FIT BOTTOM OF PIPE. THE MINIMUM THICKNESS BEFORE PLACING PIPE IS 3", 42" AND 48" RCP IRR. REQUIRE 4" DEPTH OF LOOSE BEDDING MATERIAL TO ACCOMMODATE BELL THICKNESS. AFTER LAYING CULVERT, COMPACT BEDDING MATERIAL AT HAUNCHES AND SIDES OF PIPE.
- ③ COMPACT SIDE FILL IN 6" LOOSE LAYERS TO DENSITY SPECIFIED FOR ADJACENT EMBANKMENT. SEE SECTION 203.03.3 OF THE STANDARD SPECIFICATIONS FOR THE DENSITY REQUIREMENTS.
- ④ SEE SECTION 701.04 OF THE STANDARD SPECIFICATIONS FOR BEDDING AND FOUNDATION MATERIAL REQUIREMENTS.
- ⑤ DIMENSIONS D, S AND R ARE INSIDE PIPE DIAMETER, SPAN AND RISE. DIMENSION T IS THE CULVERT SHELL THICKNESS FOR CONCRETE OR CORRUGATION WIDTH FOR METAL. CORRUGATION WIDTHS ARE TYPICALLY 1/2" FOR 48" EQUIVALENT SIZE METAL CULVERTS AND SMALLER.
- ⑥ EXCAVATE A SUFFICIENT AMOUNT TO PROVIDE A SAFE WORKING ENVIRONMENT AND TO ALLOW ACHIEVEMENT OF ALL CULVERT INSTALLATION AND COMPACTION REQUIREMENTS. SLOPE, BENCH OR PROVIDE SHORING FOR ALL EXCAVATIONS IN ACCORDANCE WITH THE U.S. DEPARTMENT OF LABOR, OCCUPATIONAL SAFETY AND HEALTH ADMINISTRATION (OSHA) SAFETY AND HEALTH REGULATIONS FOR CONSTRUCTION.
- ⑦ BUILD BERM WITH FILL MATERIAL AS NEEDED TO CONTAIN THE BEDDING MATERIAL TO THE PROPER DEPTH.

DETAILED DRAWING	
REFERENCE	DWG. NO.
STANDARD SPEC.	SECTION 207, 603, 701
	603-18
BEDDING FOR MAINLINE & PUBLIC APPROACH CULVERTS 48" EQUIVALENT & SMALLER	

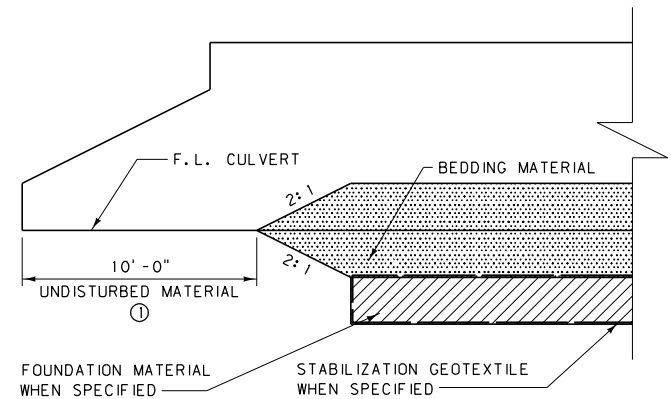
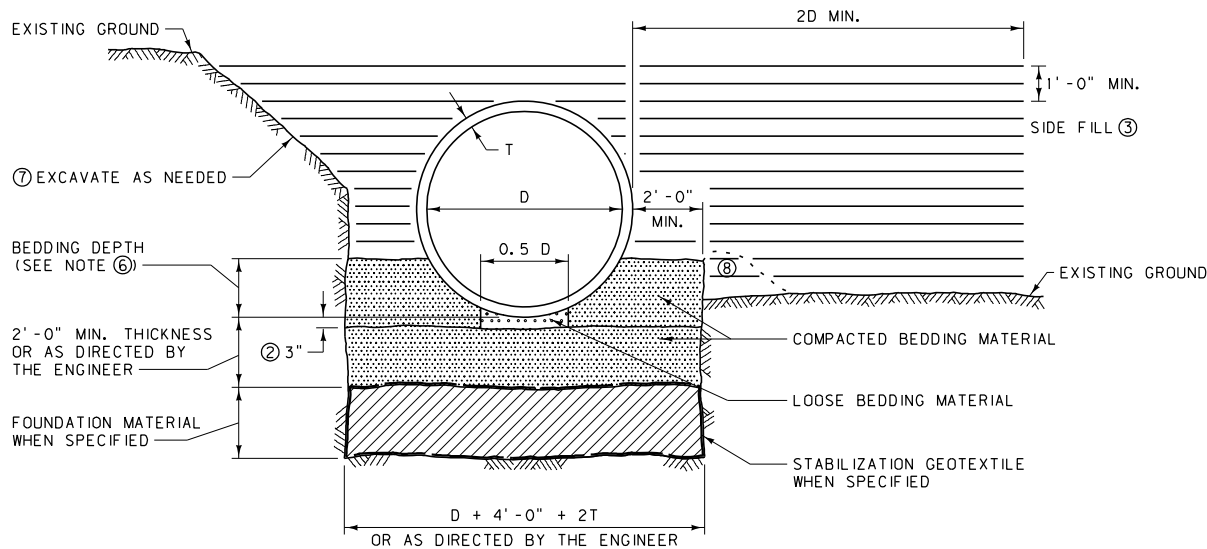

PIPE END DETAIL

NOTES:

- ① DO NOT EXTEND BEDDING MATERIAL TO THE END OF THE PIPE. LEAVE 10' OF UNDISTURBED MATERIAL AT EACH END UNLESS OTHERWISE NOTED IN PLANS. SEE PIPE END DETAIL.
- ② PLACE LOOSE BEDDING MATERIAL UNIFORMLY IN THE BOTTOM OF THE TRENCH AND SHAPE TO FIT BOTTOM OF PIPE. THE MINIMUM THICKNESS BEFORE PLACING PIPE IS 3". RCP IRR. REQUIRE GREATER THAN 3" OF LOOSE BEDDING MATERIAL TO ACCOMMODATE BELL THICKNESS. AFTER LAYING CULVERT, COMPACT BEDDING MATERIAL AT HAUNCHES AND SIDES OF PIPE.
- ③ COMPACT SIDE FILL IN 6" LOOSE LAYERS TO DENSITY SPECIFIED FOR ADJACENT EMBANKMENT. SEE SECTION 203.03.3 OF THE STANDARD SPECIFICATIONS FOR THE DENSITY REQUIREMENTS.
- ④ SEE SECTION 701.04 OF THE STANDARD SPECIFICATIONS FOR BEDDING AND FOUNDATION MATERIAL REQUIREMENTS.
- ⑤ DIMENSIONS D, S, AND R ARE THE INSIDE PIPE DIAMETER, SPAN, AND RISE. DIMENSION T IS THE CULVERT SHELL THICKNESS FOR CONCRETE OR CORRUGATION WIDTH FOR METAL.
- ⑥ THE BEDDING DEPTH FOR CONCRETE PIPE IS $D/4 + T$ OR $R/3 + T$. THE BEDDING DEPTH FOR METAL PIPE IS $"X" + T$. SEE DTL. DWG. NO. 603-32 AND 603-34 FOR "X" DIMENSIONS OF METAL PIPES.
- ⑦ EXCAVATE A SUFFICIENT AMOUNT TO PROVIDE A SAFE WORKING ENVIRONMENT AND TO ALLOW ACHIEVEMENT OF ALL CULVERT INSTALLATION AND COMPACTION REQUIREMENTS. SLOPE, BENCH OR PROVIDE SHORING FOR ALL EXCAVATIONS IN ACCORDANCE WITH THE U.S. DEPARTMENT OF LABOR, OCCUPATIONAL SAFETY AND HEALTH ADMINISTRATION (OSHA) SAFETY AND HEALTH REGULATIONS FOR CONSTRUCTION.
- ⑧ BUILD BERM WITH FILL MATERIAL AS NEEDED TO CONTAIN THE BEDDING MATERIAL TO THE PROPER DEPTH.

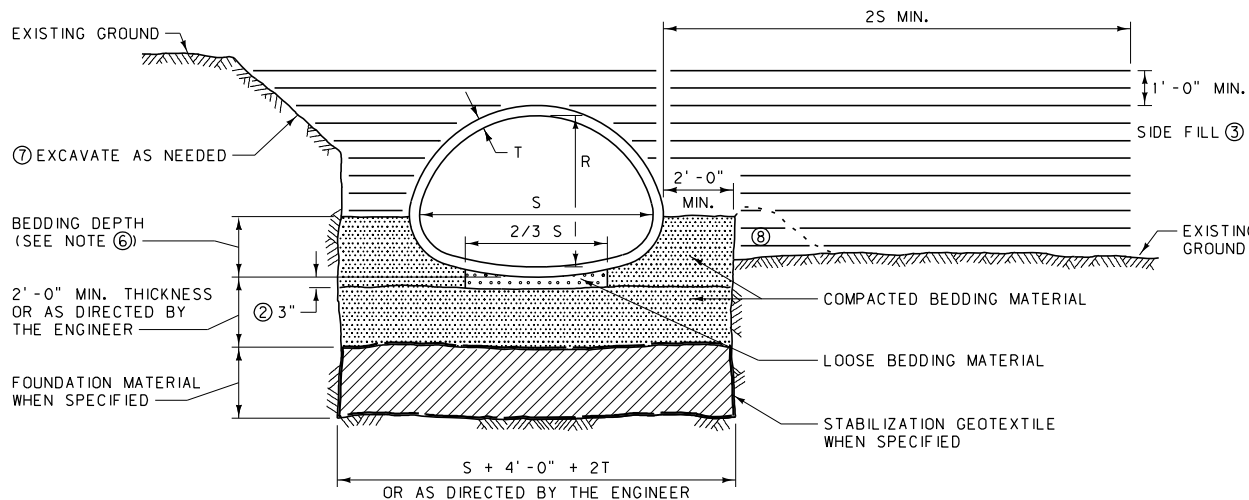

DETAILED DRAWING	
REFERENCE STANDARD SPEC.	DWG. NO. 603-19
SECTION 207, 603, 701	

BEDDING FOR CULVERTS
54" EQUIVALENT & LARGER

DIA. D	APPROX. DIA. GASKET MATL. NOT STRETCHED	LENGTH OF JOINT J	D1	D2	L2 (MIN.)	L1 (WALL "B")	L1 (WALL "C")	X1	X2	Y1	Y2	Y3
12"	2 ¹ / ₃₂ "	3 ⁵ / ₈ "	15.223"	15.331"	5"	2"	~	1"	7 ⁸ / ₈ "	0.062"	0.090"	0.313"
15"	2 ¹ / ₃₂ "	3 ⁵ / ₈ "	18.723"	18.831"	4 ³ / ₄ "	2 ³ / ₁₆ "	~	1"	7 ⁸ / ₈ "	0.062"	0.090"	0.313"
18"	2 ¹ / ₃₂ "	3 ⁵ / ₈ "	22.098"	22.206"	5"	2 ³ / ₈ "	~	1"	7 ⁸ / ₈ "	0.062"	0.090"	0.313"
21"	2 ¹ / ₃₂ "	3 ⁷ / ₈ "	25.600"	25.724"	5 ¹ / ₄ "	2 ⁹ / ₁₆ "	~	1"	7 ⁸ / ₈ "	0.062"	0.090"	0.313"
24"	2 ¹ / ₃₂ "	3 ⁷ / ₈ "	28.975"	29.099"	5 ¹ / ₂ "	2 ³ / ₄ "	2"	1"	7 ⁸ / ₈ "	0.062"	0.090"	0.313"
27"	2 ¹ / ₃₂ "	4"	32.476"	32.608"	5 ¹ / ₂ "	2 ³ / ₄ "	2"	1"	7 ⁸ / ₈ "	0.062"	0.090"	0.313"
30"	2 ¹ / ₃₂ "	4"	35.976"	36.108"	5 ¹ / ₂ "	2 ³ / ₄ "	2"	1"	7 ⁸ / ₈ "	0.062"	0.090"	0.313"
33"	2 ¹ / ₃₂ "	4 ¹ / ₈ "	39.476"	39.616"	5 ³ / ₄ "	2 ⁷ / ₈ "	2 ¹ / ₈ "	1"	7 ⁸ / ₈ "	0.062"	0.090"	0.313"
36"	2 ¹ / ₃₂ "	4 ¹ / ₈ "	42.976"	43.116"	6"	3 ¹ / ₈ "	2 ³ / ₈ "	1"	7 ⁸ / ₈ "	0.062"	0.090"	0.313"
42"	3 ¹ / ₄ "	4 ⁵ / ₈ "	50.183"	50.183"	6 ³ / ₄ "	3 ³ / ₄ "	3"	1 ³ / ₁₆ "	1"	0.067"	0.129"	0.376"
48"	3 ¹ / ₄ "	4 ³ / ₄ "	57.023"	57.193"	7 ¹ / ₄ "	4 ¹ / ₈ "	3 ³ / ₈ "	1 ³ / ₁₆ "	1"	0.067"	0.129"	0.376"
54"	3 ¹ / ₄ "	5"	63.007"	63.192"	7 ¹ / ₂ "	3 ⁵ / ₈ "	2 ⁷ / ₈ "	1 ³ / ₁₆ "	1"	0.067"	0.129"	0.376"
60"	3 ¹ / ₄ "	5"	69.007"	69.192"	7 ¹ / ₂ "	3 ¹ / ₈ "	2 ³ / ₈ "	1 ³ / ₁₆ "	1"	0.067"	0.129"	0.376"
66"	1 ³ / ₁₆ "	5"	75.007"	75.192"	7 ¹ / ₂ "	2 ³ / ₄ "	2"	1 ³ / ₁₆ "	1"	0.067"	0.129"	0.376"
72"	1 ³ / ₁₆ "	5 ¹ / ₄ "	79.250"	79.400"	~	~	~	1 ³ / ₁₆ "	1 ¹ / ₄ "	0.093"	0.190"	0.376"
78"	1 ³ / ₁₆ "	5 ¹ / ₄ "	86.250"	86.400"	~	~	~	1 ³ / ₁₆ "	1 ¹ / ₄ "	0.093"	0.190"	0.376"
84"	1 ³ / ₁₆ "	5 ¹ / ₄ "	91.500"	91.650"	~	~	~	1 ³ / ₁₆ "	1 ¹ / ₄ "	0.093"	0.190"	0.376"
90"	1 ³ / ₁₆ "	5 ¹ / ₄ "	97.750"	97.900"	~	~	~	1 ³ / ₁₆ "	1 ¹ / ₄ "	0.093"	0.190"	0.376"
96"	1 ³ / ₁₆ "	5 ¹ / ₄ "	104.250"	104.400"	~	~	~	1 ³ / ₁₆ "	1 ¹ / ₄ "	0.093"	0.190"	0.376"
102"	1 ³ / ₁₆ "	5 ¹ / ₄ "	110.750"	110.900"	~	~	~	1 ³ / ₁₆ "	1 ¹ / ₄ "	0.093"	0.190"	0.376"
108"	1 ³ / ₁₆ "	5 ¹ / ₄ "	117.250"	117.400"	~	~	~	1 ³ / ₁₆ "	1 ¹ / ₄ "	0.093"	0.190"	0.376"

72" DIA. PIPES AND LARGER

66" DIA. PIPES AND SMALLER

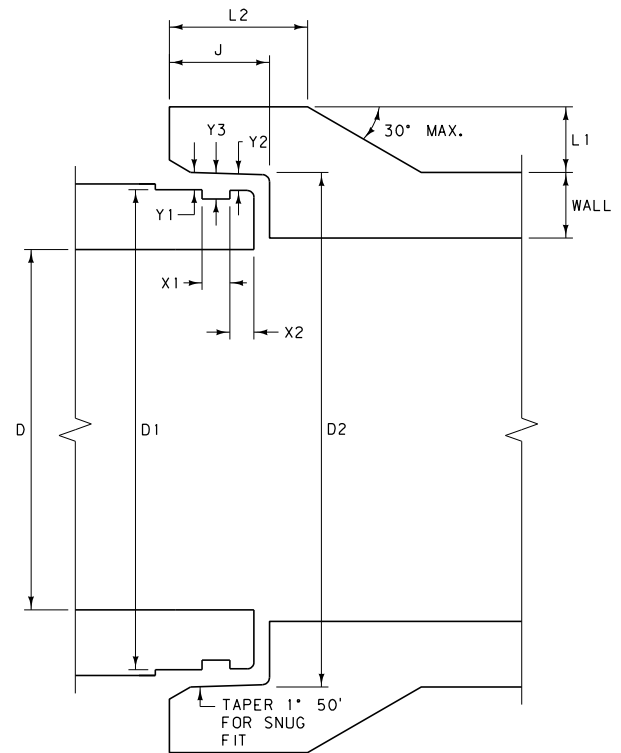
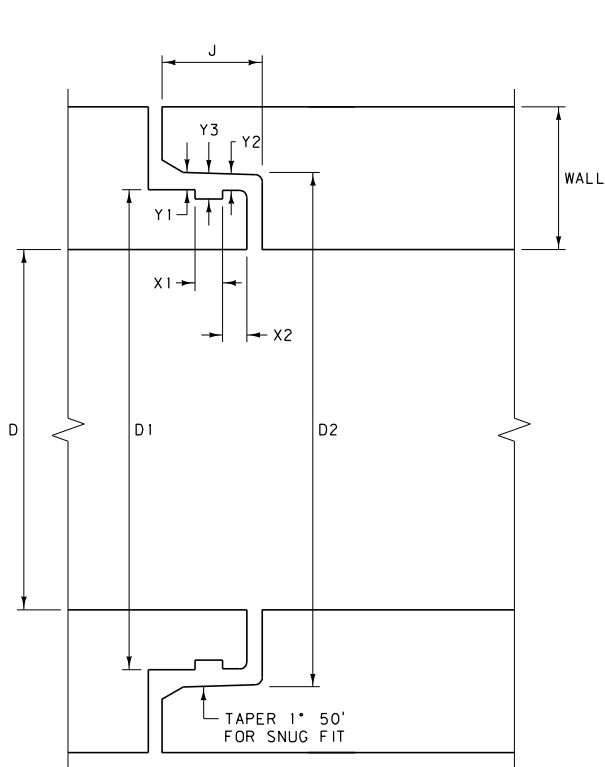

NOTES:

TYPICAL FOR STORM DRAIN AND IRRIGATION APPLICATIONS (FOR HEADS UP TO 20 FEET).

USE RUBBER GASKETS THAT MEET THE REQUIREMENTS OF STANDARD SPECIFICATION 707.02.1.

DETAILED DRAWING	
REFERENCE STANDARD SPEC. SECTION 603, 707, 708	DWG. NO. 603-22
WATER TIGHT JOINT FOR REINFORCED CONCRETE PIPE	
EFFECTIVE: FEBRUARY 2005	
 MONTANA DEPARTMENT OF TRANSPORTATION <i>servicing you with pride</i>	

DIA. D	XSEC. WATER AREA (SQ. FT.)	WT. PER L. F. OF PIPE (LB.)	T * MIN. WALL THICKNESS	J LENGTH OF JOINT	A (NOMINAL) = $\frac{D2 - D1}{2}$	D1	D2	D3	D4
12"	0.79	92	2"	1 3/4"	3/16"	13 1/4"	13 5/8"	13 7/8"	14 1/4"
15"	1.23	127	2 1/4"	2"	3/16"	16 1/2"	16 7/8"	17 1/4"	17 5/8"
18"	1.77	168	2 1/2"	2 1/4"	3/16"	19 5/8"	20"	20 3/8"	20 3/4"
21"	2.40	214	2 3/4"	2 1/2"	3/16"	22 7/8"	23 1/4"	23 3/4"	24 1/8"
24"	3.14	265	3"	2 3/4"	3/16"	26"	26 3/8"	27"	27 3/8"
27"	3.98	322	3 1/4"	3"	3/16"	29 1/4"	29 5/8"	30 1/4"	30 5/8"
30"	4.91	384	3 1/2"	3 1/4"	3/16"	32 3/8"	32 3/4"	33 1/2"	33 3/8"
33"	5.94	452	3 3/4"	3 1/2"	1/4"	35 1/2"	36"	36 3/4"	37 1/4"
36"	7.07	524	4"	3 3/4"	1/4"	38 3/4"	39 1/4"	40"	40 1/2"
42"	9.62	685	4 1/2"	4"	1/4"	45 1/8"	45 3/8"	46 1/2"	47"
48"	12.57	867	5"	4 1/4"	1/4"	51 1/2"	52"	53"	53 1/2"
54"	15.90	1070	5 1/2"	4 1/2"	1/4"	57 7/8"	58 3/8"	59 3/8"	59 7/8"
60"	19.63	1296	6"	5"	1/4"	64 1/4"	64 3/4"	66"	66 1/2"
66"	23.76	1542	6 1/2"	5 1/2"	1/4"	70 5/8"	71 1/8"	72 1/2"	73"
72"	28.27	1810	7"	6"	1/4"	77"	77 1/2"	79"	79 1/2"
78"	33.18	2098	7 1/2"	6 1/2"	1/4"	83 3/8"	83 3/8"	85 5/8"	86 1/3"
84"	38.48	2410	8"	7"	1/4"	89 3/4"	90 1/4"	92 1/8"	92 5/8"
90"	44.18	2740	8 1/2"	7"	1/4"	95 3/4"	96 1/4"	98 1/8"	98 5/8"
96"	50.27	2950	9"	7"	1/4"	102 1/8"	102 5/8"	104 1/2"	105"
102"	56.75	3075	9 1/2"	7 1/2"	1/4"	109"	109 1/2"	111 1/2"	112"
108"	63.62	3870	10"	7 1/2"	1/4"	115 1/2"	116"	118"	118 1/2"

* WALL "B" THICKNESS

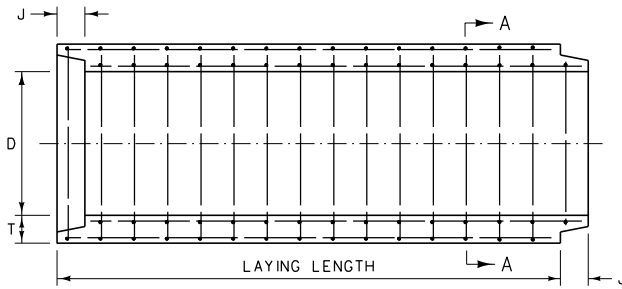

TYPICAL LONGITUDINAL SECTION
36" DIAMETER PIPES AND LARGER

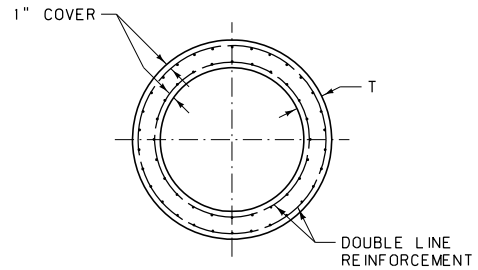

SECTION A-A

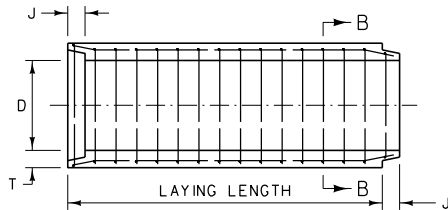

TYPICAL LONGITUDINAL SECTION
33" DIAMETER PIPES AND SMALLER

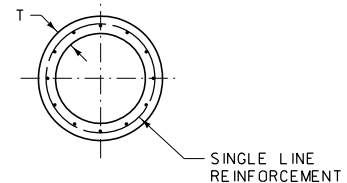

SECTION B-B

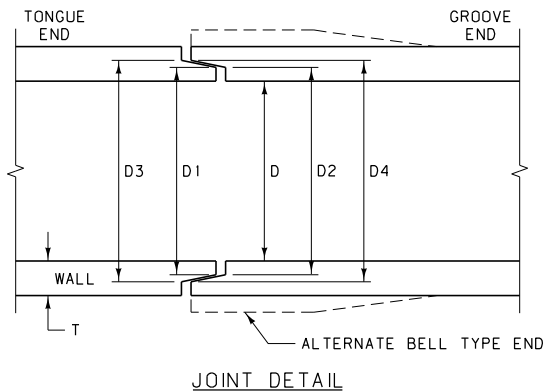

JOINT DETAIL

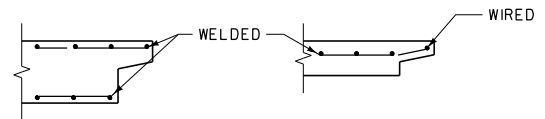

REINFORCING AT ENDS OF PIPE

NOTES:

TOLERANCES IN DIMENSIONS IN ACCORDANCE WITH AASHTO M 170.

TYPICAL FOR DRAINAGE APPLICATIONS.

DETAILED DRAWING	
REFERENCE STANDARD SPEC. SECTION 603, 708	DWG. NO. 603-24
REINFORCED CONCRETE PIPE JOINT	
EFFECTIVE: FEBRUARY 2005	
 MONTANA DEPARTMENT OF TRANSPORTATION <i>servicing you with pride</i>	

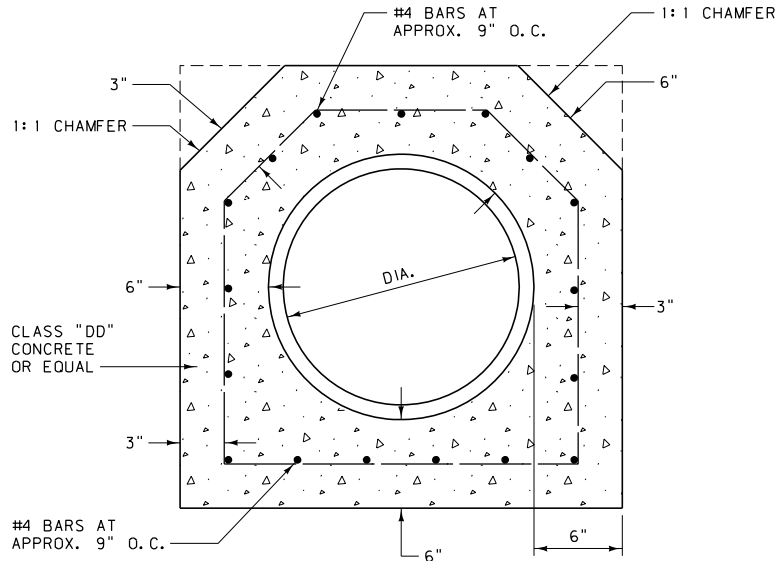

SECTION A-A

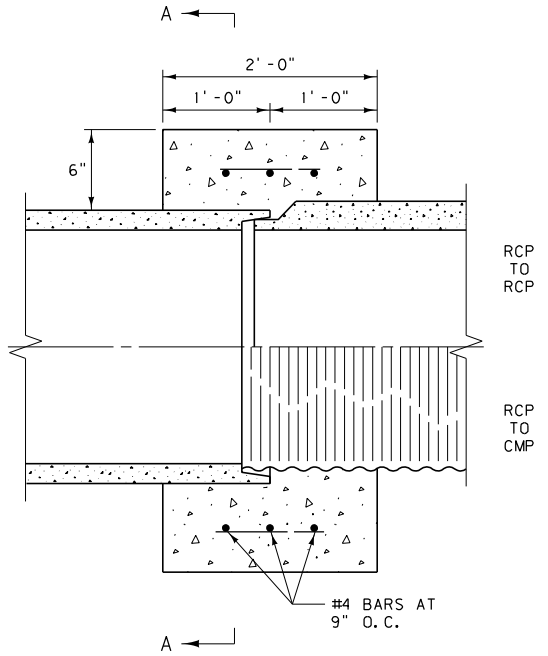

CONNECTION DETAILS

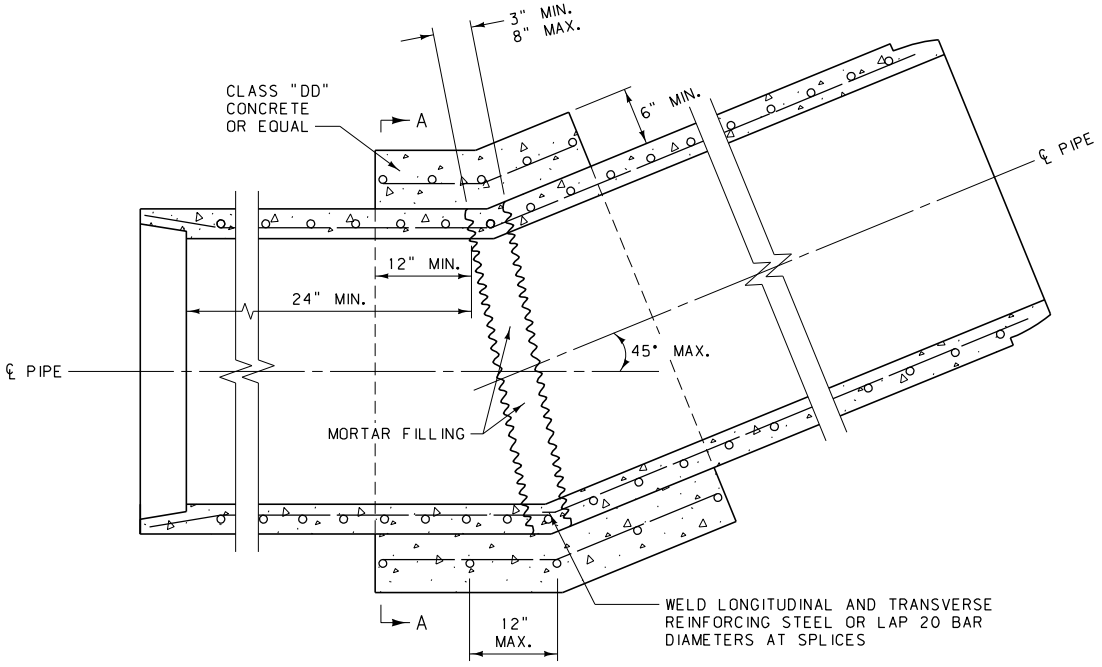

TYPICAL FIELD CAST CONCRETE BEND

DETAILED DRAWING	
REFERENCE STANDARD SPEC. SECTION 603, 708	DWG. NO. 603-26
TYPICAL FIELD CAST CONCRETE CONNECTIONS	
EFFECTIVE: FEBRUARY 2005	
 MONTANA DEPARTMENT OF TRANSPORTATION <i>servicing you with pride</i>	

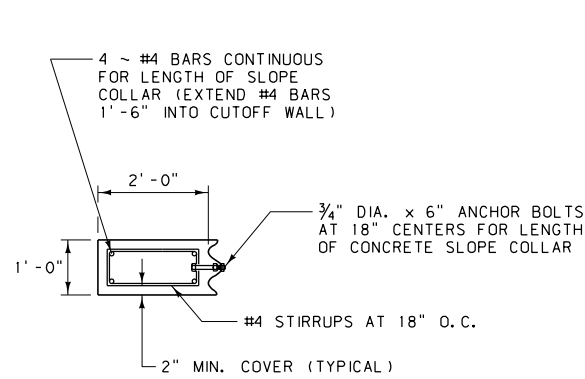

NOTE:
SEE DTL. DWG. NO. 552-00
FOR ANCHOR BOLT DETAILS.

3/4" DIA. ANCHOR BOLTS AT
APPROX. 18" CENTERS FOR
LENGTH OF CONCRETE SLOPE
COLLAR (TYPICAL)

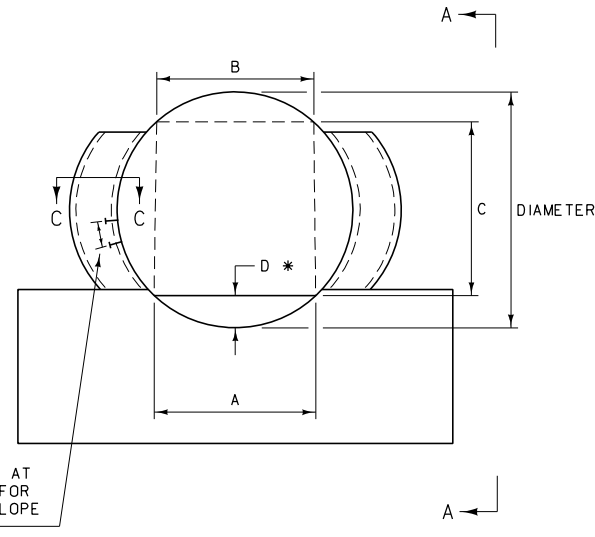

ELEVATION

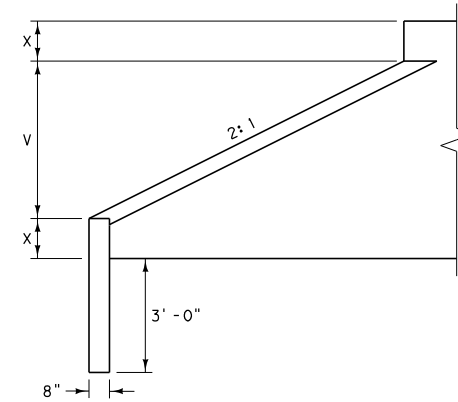

SECTION A-A

NOTES:

DESIGNATE THESE STRUCTURES, IN PLANS AND PROPOSAL, AS "VEHICULAR UNDERPASS." CONFORM MATERIALS, INSTALLATION, AND OTHER PROVISIONS TO THE STANDARD SPECIFICATIONS. USE THE TERM "VEHICULAR UNDERPASS," REGARDLESS OF THE USE OR PURPOSE OF THE STRUCTURE.

PROVIDE END TREATMENT FOR ALL VEHICULAR UNDERPASSES INCLUDING CUTOFF WALLS, BACKFILL RETAINING WALLS AND CONCRETE SLOPE COLLARS.

PROVIDE SURFACING FOR THE INSIDE OF THE STRUCTURE, CROSS-SLOPED TO ALLOW A DRAINAGE COURSE ALONG ONE SIDE.

FOR PLATE THICKNESS SEE ROAD DESIGN MANUAL FILL HEIGHT TABLES.

USE CLASS "DD" CONCRETE OR EQUAL.

SEE DTL. DWG. NO. 552-08 FOR QUANTITIES.

DEPTH OF SURFACING *		
MATERIAL	ALTERNATE "A"	ALTERNATE "B"
PL. MIX SURF.	—	0.20'
CRUSHED AGGREGATE COURSE	BAL.	BAL.

DIAMETER	A	B	C	V	X	* D	BACKFILL RETAINER (C. Y.)	CONCRETE COLLAR (C. Y.)
96"	4'	4'	6.9'	4.0'	2.0'	0.5'	0.04	0.66
120"	7'	7'	7.1'	5.0'	2.5'	1.4'	0.17	0.82
150"	10'	8'	8.6'	6.25'	3.13'	2.5'	0.43	1.08
162"	10'	8'	10.0'	6.75'	3.38'	2.2'	0.38	1.16
186"	12'	10'	10.8'	7.75'	3.88'	2.9'	0.59	1.34
192"	12'	10'	11.5'	8.0'	4.0'	2.7'	0.55	1.38
204"	12'	10'	12.9'	8.5'	4.25'	2.5'	0.51	1.46
216"	12'	10'	14.2'	9.0'	4.50'	2.3'	0.47	1.54
228"	16'	12'	12.5'	9.5'	4.75'	4.4'	1.23	1.72
240"	16'	12'	14.0'	10.0'	5.0'	4.0'	1.10	1.72

DIAMETER	SURFACING QUANTITIES PER LINEAR FOOT FOR DEPTH "D" *					
	ALTERNATE "A"			ALTERNATE "B"		
	C. Y. SURFACING	TONS SURFACING		C. Y. SURFACING	TONS BIT. MATL.	
	CRUSHED AGGREGATE COURSE	COVER MATERIAL	PLANT MIX	CRUSHED AGGREGATE COURSE	PLANT MIX	PRIME SEAL
96"	0.054	0.0056	0.052	0.027	0.0031	0.0005 0.0007
120"	0.255	0.0097	0.097	0.205	0.0058	0.0009 0.0012
150"	0.647	0.0139	0.141	0.574	0.0084	0.0014 0.0017
162"	0.563	0.0139	0.140	0.489	0.0084	0.0014 0.0017
186"	0.882	0.0167	0.169	0.794	0.0102	0.0017 0.0020
192"	0.830	0.0167	0.168	0.744	0.0101	0.0016 0.0020
204"	0.769	0.0167	0.169	0.680	0.0102	0.0016 0.0020
216"	0.702	0.0167	0.168	0.615	0.0101	0.0016 0.0020
228"	1.842	0.0222	0.227	1.725	0.0136	0.0022 0.0026
240"	1.656	0.0222	0.226	1.539	0.0136	0.0022 0.0026

BACKFILL RETAINER & CUTOFF WALL DETAIL

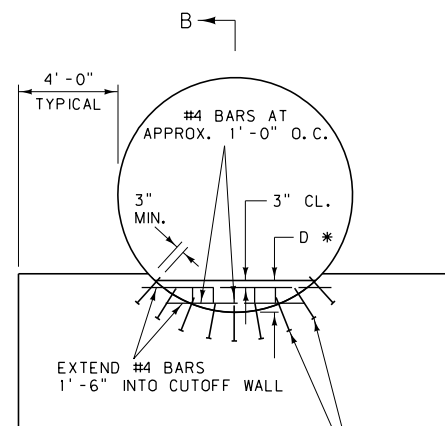

ELEVATION

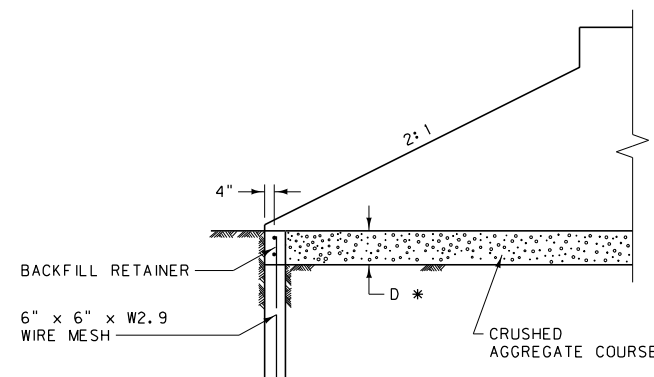

SECTION B-B
(ALTERNATE "A")

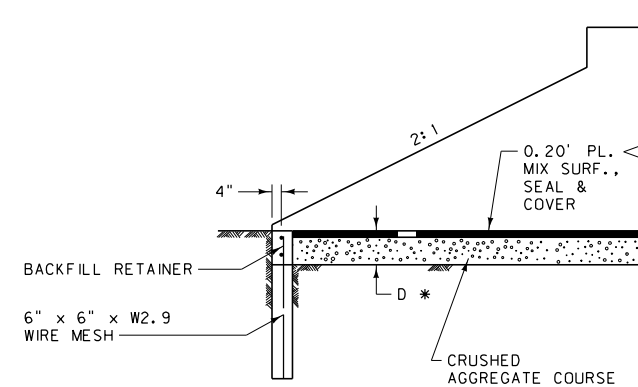

SECTION B-B
(ALTERNATE "B")

NOTE:
INCLUDE CONCRETE COLLAR
WHEN SPECIFIED.

DETAILED DRAWING	
REFERENCE STANDARD SPEC. SECTION 552, 603	DWG. NO. 603-30
VEHICULAR UNDERPASS AND BACKFILL RETAINER & CUTOFF WALL DETAIL	

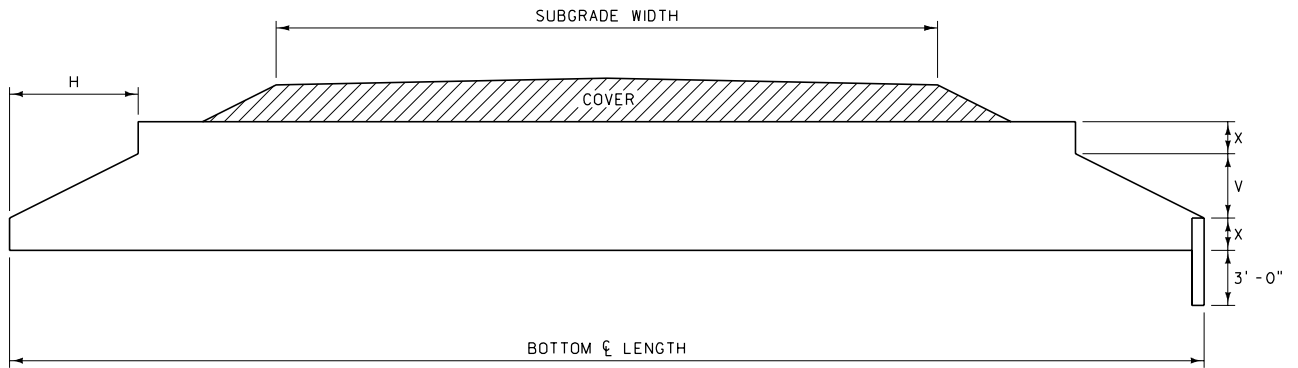

NOTE:
FOR DETAILS COVERING CUTOFF WALLS
SEE DTL. DWG. NO. 552-00.

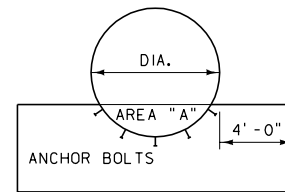

DIA.	X (FT.)	V (FT.)	H (FT.) FOR BEVELS:		AREA "A" (SQ. FT.) *
			1.5:1	2:1	
CSP 3" x 1" OR 5" x 1" CORRUGATIONS					
54"	1.125	2.250	3.375	4.500	3.31
60"	1.250	2.500	3.750	5.000	4.06
66"	1.375	2.750	4.125	5.500	4.89
72"	1.500	3.000	4.500	6.000	5.79
78"	1.625	3.250	4.875	6.500	6.77
84"	1.750	3.500	5.250	7.000	7.83
90"	1.875	3.750	5.625	7.500	8.97
96"	2.000	4.000	6.000	8.000	10.18
102"	2.125	4.250	6.375	8.500	11.47
108"	2.250	4.500	6.750	9.000	12.83
114"	2.375	4.750	7.125	9.500	14.27
120"	2.500	5.000	7.500	10.000	15.79

DIA.	X (FT.)	V (FT.)	H (FT.) FOR BEVELS:		AREA "A" (SQ. FT.) *
			1.5:1	2:1	
SSPP 6" x 2" CORRUGATIONS					
10'-6"	2.625	5.250	7.875	10.500	17.39
11'-0"	2.750	5.500	8.250	11.000	19.06
11'-6"	2.875	5.750	8.625	11.500	20.81
12'-0"	3.000	6.000	9.000	12.000	22.64
12'-6"	3.125	6.250	9.375	12.500	24.54
13'-0"	3.250	6.500	9.750	13.000	26.52
13'-6"	3.375	6.750	10.125	13.500	28.58
14'-0"	3.500	7.000	10.500	14.000	30.71
14'-6"	3.625	7.250	10.875	14.500	32.92
15'-0"	3.750	7.500	11.250	15.000	35.21
15'-6"	3.875	7.750	11.625	15.500	37.57
16'-0"	4.000	8.000	12.000	16.000	40.01
16'-6"	4.125	8.250	12.375	16.500	42.53
17'-0"	4.250	8.500	12.750	17.000	45.12
17'-6"	4.375	8.750	13.125	17.500	47.79
18'-0"	4.500	9.000	13.500	18.000	50.54
19'-0"	4.750	9.500	14.250	19.000	56.26
20'-0"	5.000	10.000	15.000	20.000	62.29
21'-0"	5.250	10.500	15.750	21.000	68.63

* AREA "A" IS TO THE MIDDLE OF THE CORRUGATIONS.

DETAILED DRAWING	
REFERENCE STANDARD SPEC. SECTION 603	DWG. NO. 603-32
STEP BEVEL FOR CIRCULAR METAL CULVERT	
--REVISED-- May 2009	EFFECTIVE: APRIL 2006
 MONTANA DEPARTMENT OF TRANSPORTATION <i>-serving you with pride-</i>	

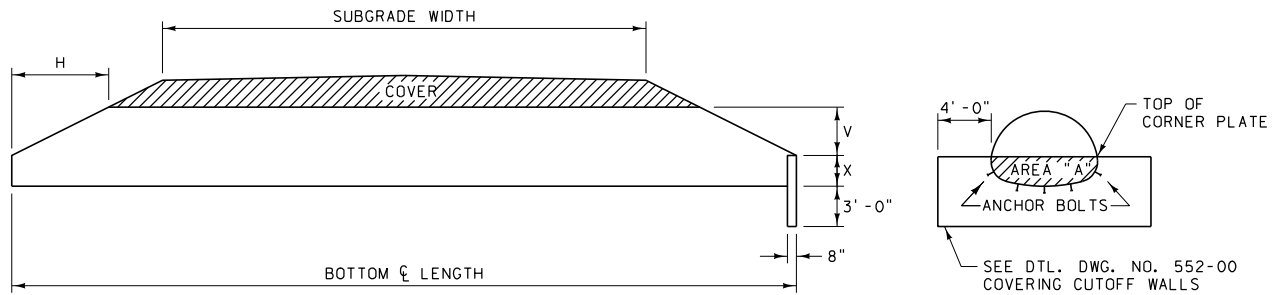

SPAN	RISE	EQUIV. DIA.	X (FT.)	V (FT.)	H (FT.) FOR BEVELS:			AREA "A" (SQ. FT.)
					1.5:1	2:1	2.5:1	
SSPPA 6" x 2" CORRUGATIONS WITH 18" CORNER RADIUS								
6'-1"	4'-7"	66"	2.3	2.3	3.4	4.6	5.7	12.8
6'-9"	4'-11"	72"	2.4	2.5	3.8	5.0	6.3	14.8
7'-3"	5'-3"	78"	2.1	3.2	4.7	6.3	7.9	14.1
7'-11"	5'-7"	84"	2.3	3.3	4.9	6.6	8.2	16.8
8'-7"	5'-11"	90"	2.3	3.6	5.4	7.2	9.0	18.0
9'-4"	6'-3"	96"	2.5	3.8	5.6	7.5	9.4	21.0
9'-9"	6'-7"	102"	2.2	4.4	6.6	8.8	11.0	19.8
10'-8"	6'-11"	108"	2.8	4.1	6.2	8.2	10.3	26.6
11'-5"	7'-3"	114"	2.8	4.5	6.7	8.9	11.1	27.9
11'-10"	7'-7"	120"	2.5	5.1	7.6	10.2	13.6	26.4
12'-6"	7'-11"	126"	2.7	5.2	7.8	10.4	13.0	30.0
12'-10"	8'-4"	132"	2.3	6.0	8.9	11.9	14.9	26.9
SSPPA 6" x 2" CORRUGATIONS WITH 31" CORNER RADIUS								
13'-3"	9'-4"	~	3.9	5.5	8.2	10.9	13.6	45.7
13'-6"	9'-6"	~	3.8	5.7	8.6	11.5	14.3	45.7
14'-0"	9'-8"	144"	4.0	5.7	8.5	11.4	14.2	49.1
14'-3"	9'-10"	~	3.8	6.1	9.1	12.1	15.2	47.6
14'-5"	10'-0"	~	3.7	6.3	9.5	12.7	15.9	47.4
14'-11"	10'-2"	~	4.0	6.2	9.3	12.4	15.5	52.4
15'-4"	10'-4"	156"	4.3	6.0	9.1	12.1	15.1	57.6
15'-7"	10'-6"	~	4.1	6.4	9.6	12.8	16.1	55.9
15'-10"	10'-8"	~	3.9	6.8	10.2	13.6	17.0	54.2
16'-3"	10'-10"	~	4.3	6.5	9.8	13.1	16.4	61.1
16'-6"	11'-0"	168"	4.1	6.9	10.4	13.9	17.3	59.4
17'-0"	11'-2"	~	4.4	6.8	10.2	13.6	17.0	64.7
17'-2"	11'-4"	~	4.3	7.1	10.6	14.1	17.6	64.6
17'-5"	11'-6"	~	4.1	7.4	11.2	14.9	18.6	62.6
17'-11"	11'-8"	180"	4.3	7.4	11.1	14.8	18.5	66.6
18'-1"	11'-10"	~	4.2	7.7	11.5	15.3	19.2	66.4
18'-7"	12'-0"	~	4.5	7.5	11.3	15.0	18.8	72.2
18'-9"	12'-2"	~	4.3	7.9	11.8	15.8	19.7	70.1
19'-3"	12'-4"	192"	4.6	7.7	11.6	15.5	19.4	76.3
19'-6"	12'-6"	~	4.4	8.1	12.2	16.3	20.3	74.1
19'-8"	12'-8"	~	4.3	8.4	12.6	16.8	21.0	73.7
19'-11"	12'-10"	~	4.1	8.8	13.2	17.6	22.0	71.3
20'-5"	13'-0"	204"	4.4	8.6	12.9	17.3	21.6	77.6
20'-7"	13'-2"	~	4.3	8.9	13.4	17.8	22.3	77.2

SPAN	RISE	EQUIV. DIA.	X (FT.)	V (FT.)	H (FT.) FOR BEVELS:			AREA "A" (SQ. FT.)
					1.5:1	2:1	2.5:1	
CSPA 3" x 1" CORRUGATIONS (SEE NOTE ⓧ)								
60"	46"	54"	1.7	2.3	3.5	4.7	5.8	7.1
66"	51"	60"	1.9	2.6	3.9	5.2	6.5	8.7
73"	55"	66"	2.1	2.8	4.1	5.5	6.9	10.7
81"	59"	72"	2.0	3.2	4.8	6.5	8.1	11.1
87"	63"	78"	2.1	3.5	5.2	6.9	8.6	13.2
95"	67"	84"	2.3	3.7	5.5	7.3	9.2	15.3
103"	71"	90"	2.5	3.9	5.8	7.7	9.6	17.8
112"	75"	96"	2.6	4.1	6.1	8.1	10.2	20.2
117"	79"	102"	2.8	4.3	6.4	8.5	10.7	23.1
128"	83"	108"	3.0	4.5	6.7	8.9	11.2	25.9
137"	87"	114"	3.1	4.7	7.0	9.4	11.7	29.0
142"	91"	120"	3.3	4.9	7.3	9.7	12.2	32.2
CSPA 2 2/3" x 1/2" CORRUGATIONS (SEE NOTE ⓧ)								
57"	38"	48"	1.1	2.1	3.1	4.2	5.2	4.5
64"	43"	54"	1.2	2.4	3.5	4.7	5.9	5.6
71"	47"	60"	1.4	2.6	3.8	5.1	6.4	6.9
77"	52"	66"	1.5	2.8	4.3	5.7	7.1	8.2
83"	57"	72"	1.6	3.1	4.7	6.3	7.8	9.6

NOTES:

BEVEL TO TOP OF CORNER PLATE.

PIPE ENDS ARE SQUARE (PERPENDICULAR TO CENTERLINE OF PIPE) AND FILL SLOPES ARE WARPED TO ACCOMMODATE THE SQUARE ENDS UNLESS SPECIFIED OTHERWISE ON PLANS.

ⓧ TABULATED VALUES BASED ON NOMINAL PIPE DIMENSIONS. IN PLACE DIMENSIONS SUBJECT TO TOLERANCES LISTED IN CURRENT AASHTO M 36 AND M 196.

DETAILED DRAWING	
REFERENCE STANDARD SPEC. SECTION 603	DWG. NO. 603-34
BEVEL ON ARCH METAL CULVERT	
EFFECTIVE: FEBRUARY 2005	
 MONTANA DEPARTMENT OF TRANSPORTATION <i>servicing you with pride</i>	

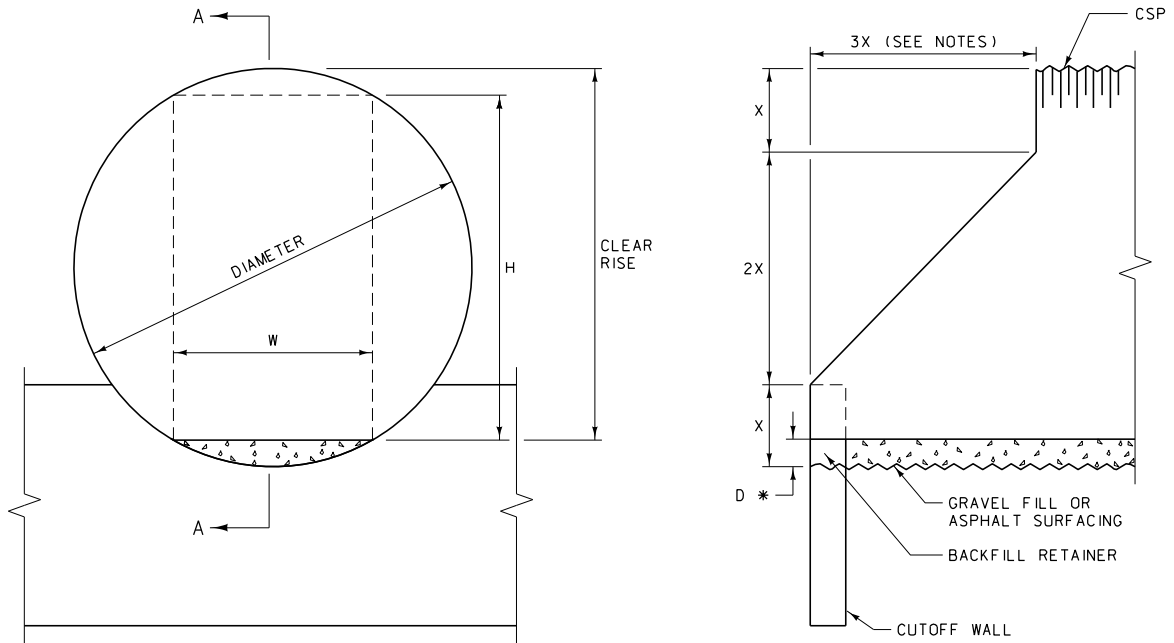

SECTION A-A

DIAMETER	X	* D	CLEAR RISE	H	W	BACKFILL RETAINER (CUBIC YARDS)
84"	21.0"	0.50'	6.5'	6.0'	3.6'	0.1
90"	22.5"	0.75'	6.75'	6.0'	4.5'	0.1
96"	24.0"	0.83'	7.17'	6.34'	4.9'	0.1

DIAMETER	SURFACING QUANTITIES PER LINEAR FOOT FOR DEPTH "D" *				
	FULL DEPTH GRAVEL	0.20' PMS AND REMAINING DEPTH GRAVEL			
	C. Y. SURF.	TONS SURF.	C. Y. SURF.	TONS BIT. MATERIAL	
	CR. TOP SURF.	PLANT MIX	CR. TOP SURF.	PLANT MIX	PRIME
84"	0.045	0.046	0.021	0.0028	0.0004
90"	0.085	0.060	0.054	0.0036	0.0006
96"	0.102	0.066	0.068	0.0040	0.0006

NOTES:

UNLESS OTHERWISE SPECIFIED, INSTALL STOCKPASSES WITH CUTOFF WALLS AND BACKFILL RETAINERS AT EACH END, GRAVEL FILL AND BEDDING MATERIAL.

WHEN SPECIFIED, INSTALL COMBINATION STOCKPASSES AND DRAINS WITH CUTOFF WALLS, BACKFILL RETAINERS AT BOTH ENDS, CONCRETE EDGE PROTECTION AT THE INLET END, RANDOM RIPRAP AT THE OUTLET END, BEDDING MATERIAL AND ASPHALT SURFACING; CROSS SLOPE ASPHALT SURFACING TO ALLOW DRAINAGE COURSE ALONG ONE SIDE. (SEE DTL. DWG. NO. 613-14 AND 613-06.)

UNLESS OTHERWISE SPECIFIED, STEP BEVEL PIPE ENDS AT A 1.5:1 SLOPE.

THE MINIMUM THICKNESS FOR CORRUGATED STEEL PIPE STOCKPASS IS 0.079". (SEE FILL HEIGHT TABLES FOR OTHER THAN THE MINIMUM REQUIREMENTS.)

SEE DTL. DWG. NO. 552-00, 603-30 AND 603-18.

DETAILED DRAWING	
REFERENCE STANDARD SPEC. SECTION 603	DWG. NO. 603-36
CORRUGATED STEEL PIPE STOCKPASS	
EFFECTIVE: FEBRUARY 2005	
 MONTANA DEPARTMENT OF TRANSPORTATION <i>-serving you with pride</i>	