

Ⓐ ALL WARNING SIGNS ARE 1200 x 1200 IN SIZE.
 Ⓑ DIMENSIONS ARE FROM Ⓢ BOLT TO Ⓢ BOLT.

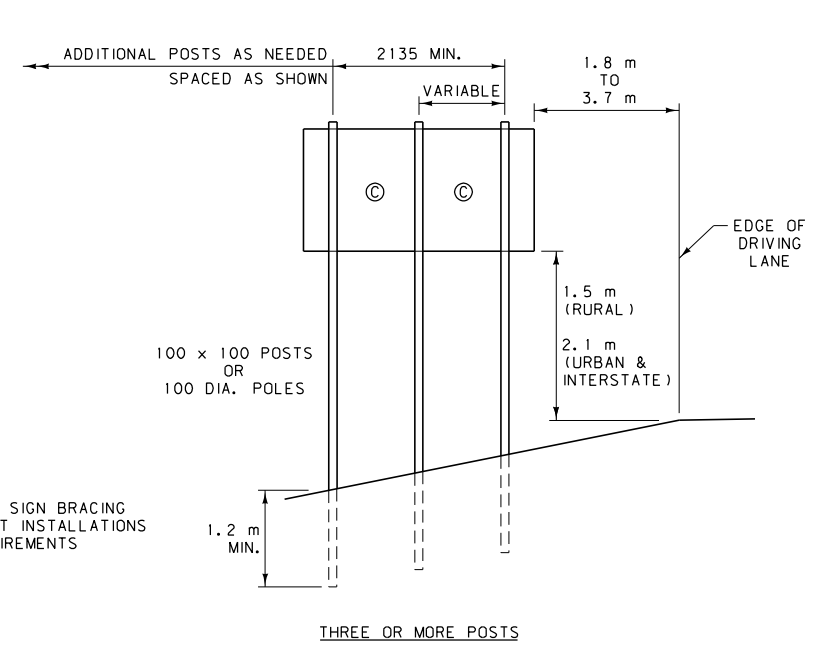

TYPICAL MULTIPLE POST INSTALLATIONS
 (FOR CONSTRUCTION SIGNING ONLY)

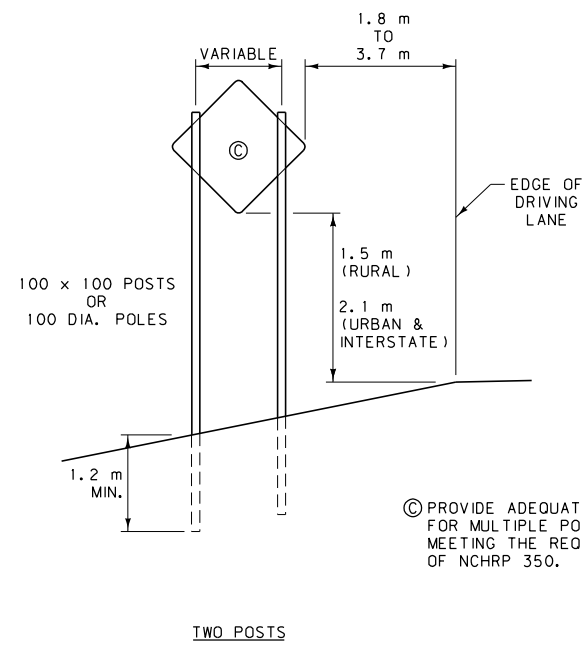
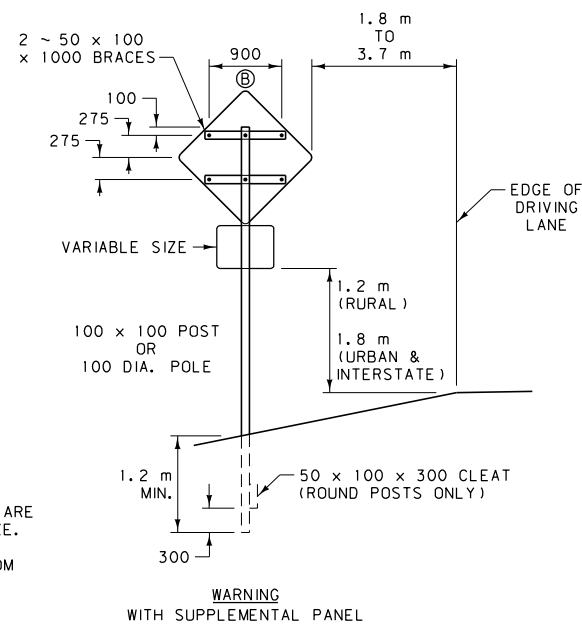
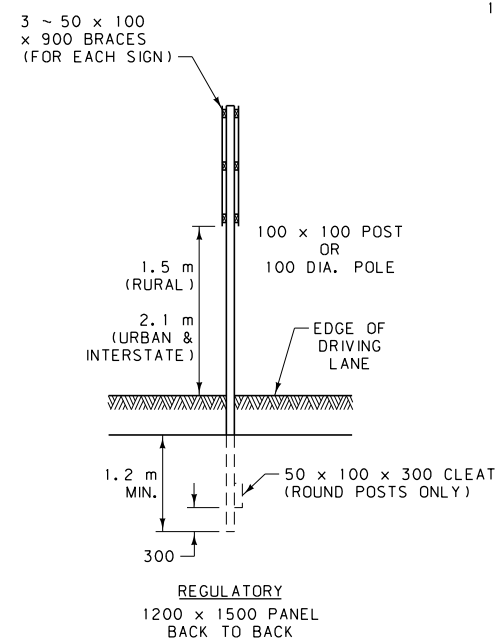
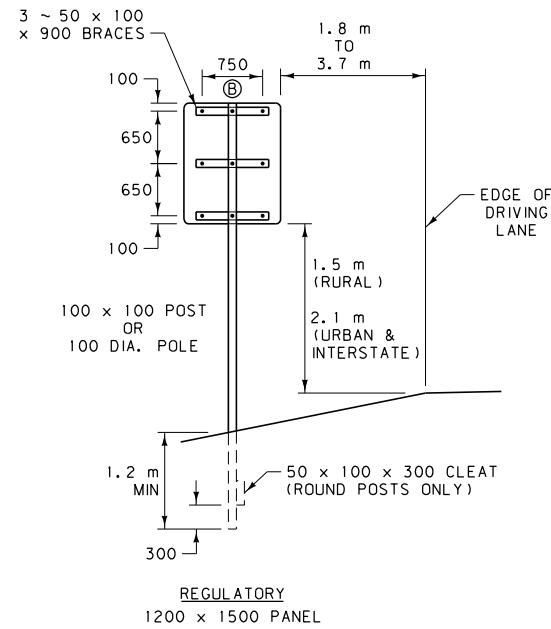

TYPICAL SIGN MOUNTINGS
 (FOR CONSTRUCTION SIGNING ONLY)

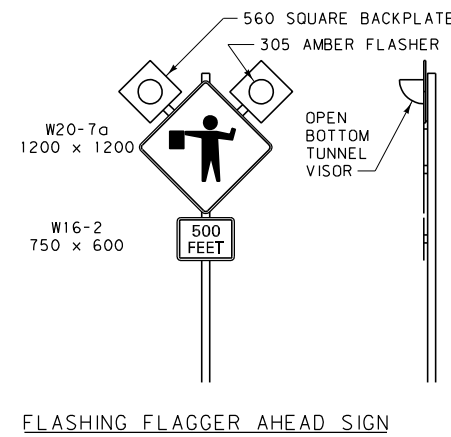
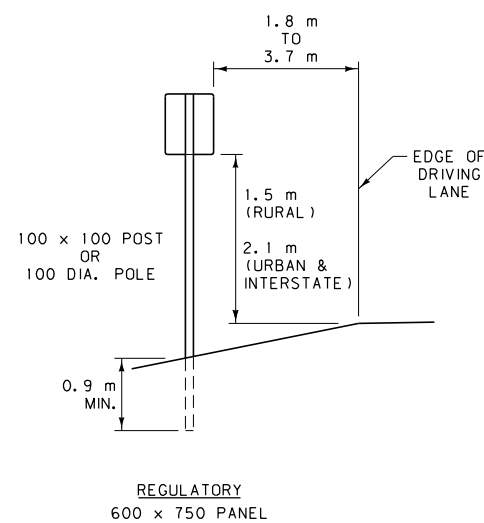

FLASHING FLAGGER AHEAD SIGN

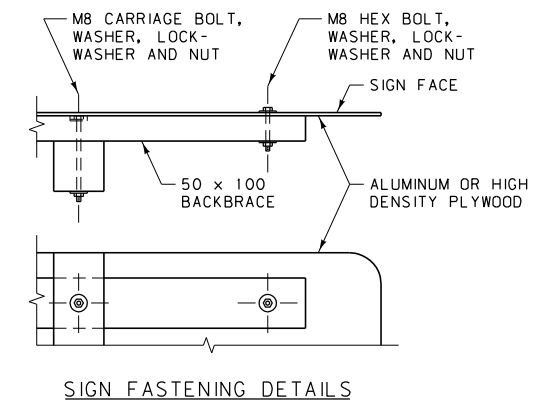

SIGN FASTENING DETAILS

NOTES:

- ① FURNISH AND INSTALL POSTS OR POLES MEETING NCHRP 350 REQUIREMENTS.
- ② FURNISH POST OR POLE LENGTHS TO ACCOMMODATE THE FOUNDATION DEPTH, THE MOUNTING HEIGHT AND THE MOUNTINGS.
- ③ BACKFILL FOUNDATION HOLES IN 205 mm LIFTS, THOROUGHLY TAMPING EACH LIFT.
- ④ IN HIGH WIND AREAS INSTALL LARGER POSTS OR POLES COMPLYING WITH THE FOUNDATION AND BREAKAWAY REQUIREMENTS OF DTL. DWG. 619-20. THE MINIMUM POST SPACING FOR MULTIPLE POSTS LARGER THAN 100 mm IS 2135 mm.
- ⑤ VERTICAL ALIGNMENT OF SIGNS IS TO BE WITHIN 5° OF PLUMB (85 mm IN 1000 mm).
- ⑥ USE THE URBAN MOUNTING HEIGHTS IN BUSINESS, COMMERCIAL, AND RESIDENTIAL DISTRICTS WHERE PARKING AND/OR PEDESTRIAN MOVEMENT IS LIKELY TO OCCUR, OR WHERE THERE ARE OTHER OBSTRUCTIONS TO VIEW. URBAN MOUNTING HEIGHTS MAY ALSO BE USED IN RURAL AREAS FOR INCREASED VISIBILITY.

ALL DIMENSIONS ARE MILLIMETERS (mm) UNLESS OTHERWISE NOTED.

DETAILED DRAWING	
REFERENCE STANDARD SPEC. SECTION 618	DWG. NO. 618-01
CONSTRUCTION SIGN DETAILS	
EFFECTIVE: FEBRUARY 2005	
 MONTANA DEPARTMENT OF TRANSPORTATION	

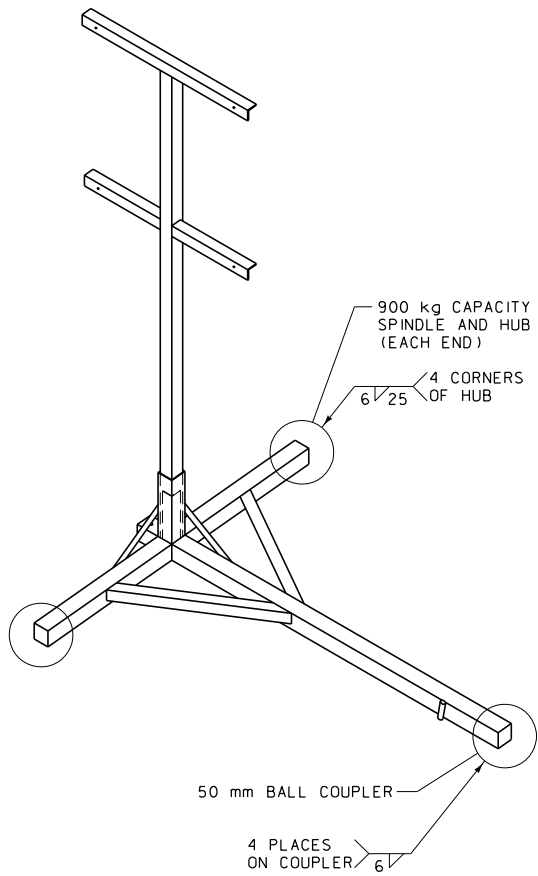

NOTES:

- ① THE MAXIMUM WEIGHT OF THE ASSEMBLY IS 115 kg.
- ② USE A 355 mm WHEEL AND TIRE.
- ③ AUTOMOTIVE AND EQUIPMENT AXLE ASSEMBLIES MAY NOT BE USED FOR TRAILER-MOUNTED SIGN SUPPORTS.
- ④ OTHER NCHRP 350 CRASH TESTED ASSEMBLIES ARE ACCEPTABLE.

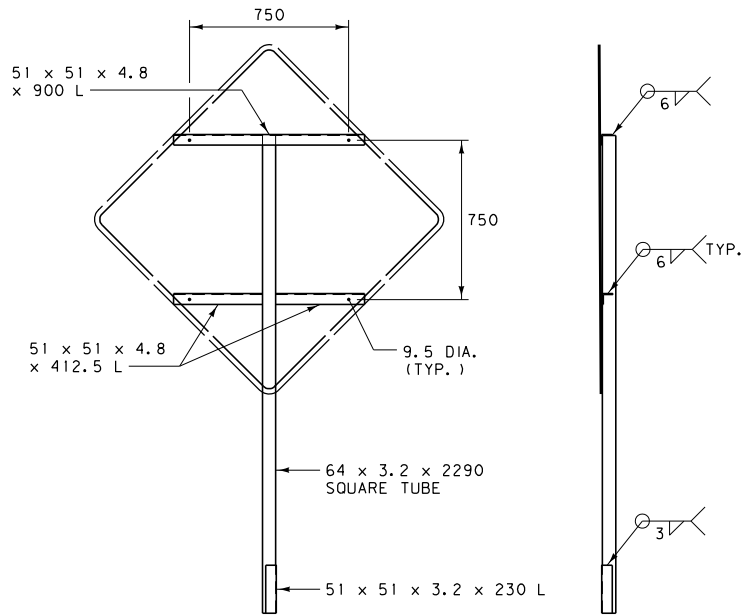

FRONT

RIGHT

SIGN SUPPORT

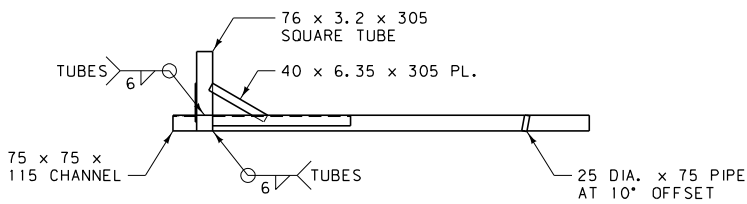

FRONT

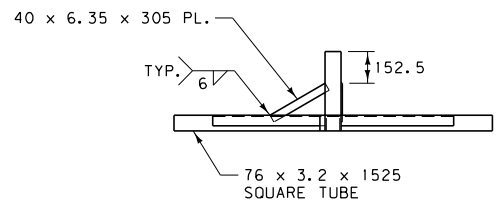

RIGHT

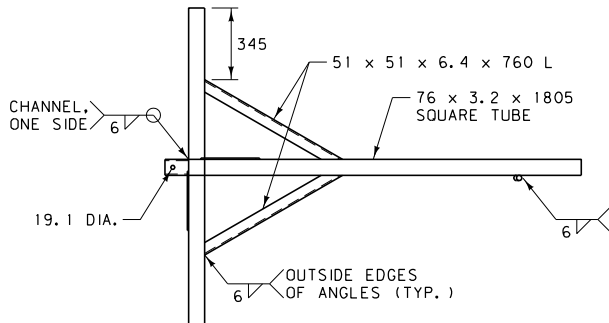

TOP

TRAILER

ALL DIMENSIONS ARE MILLIMETERS (mm) UNLESS OTHERWISE NOTED.

DETAILED DRAWING	
REFERENCE STANDARD SPEC. SECTION 618.715	DWG. NO. 618-02
PORTABLE SIGN SUPPORT ASSEMBLY	
EFFECTIVE: FEBRUARY 2005	
 MONTANA DEPARTMENT OF TRANSPORTATION <i>servicing you with pride</i>	

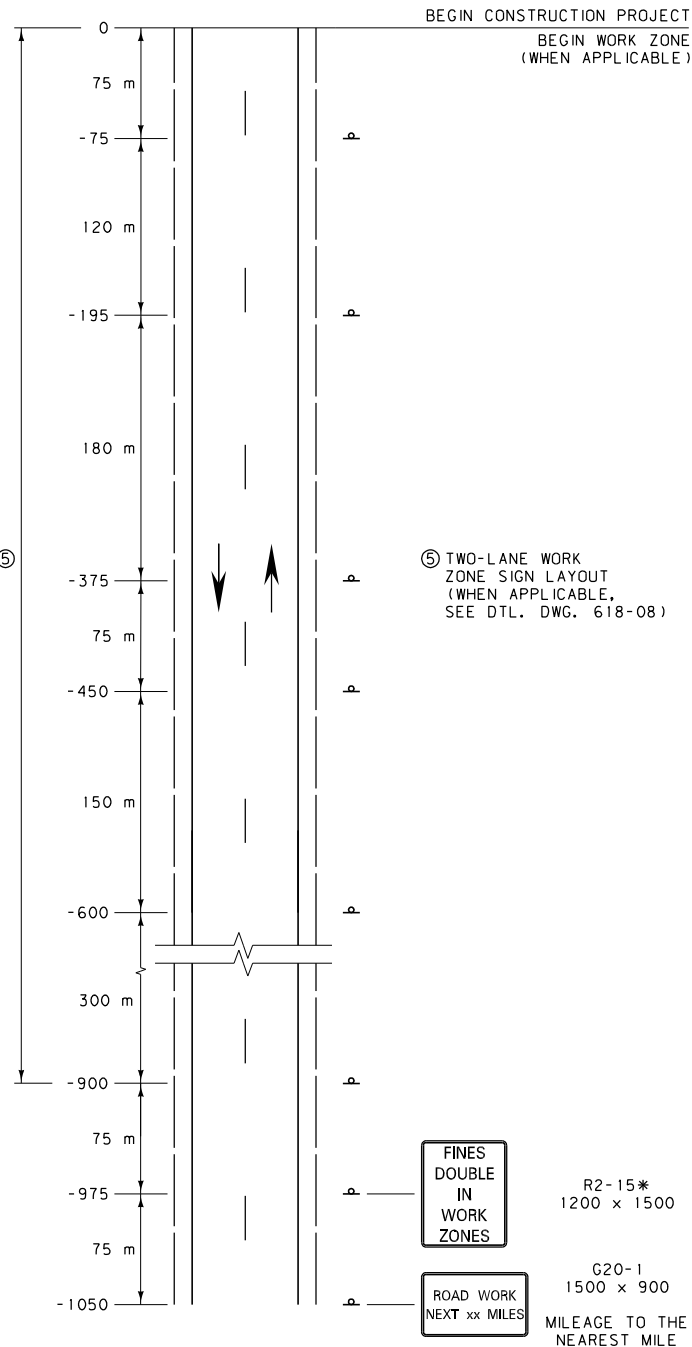
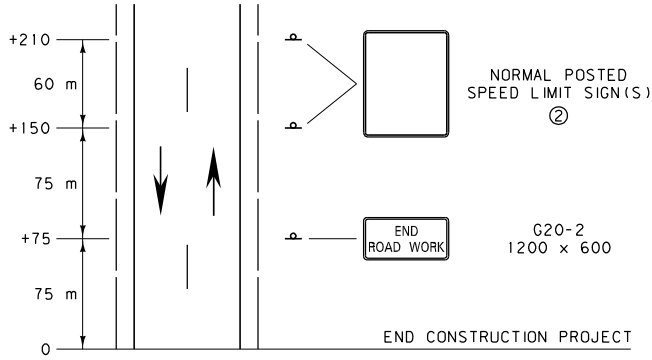

NOTES:

- ① THIS SIGN LAYOUT IS INTENDED TO BE A PERMANENT INSTALLATION FOR THE DURATION OF THE CONSTRUCTION PROJECT, AS APPROVED BY THE ENGINEER. COVER OR REMOVE ANY SIGNS WHEN NOT IN USE, INCLUDING SPEED LIMIT SIGNS NOT WARRANTED. REMOVE ANY SIGN SUPPORTS IF THEY WILL NOT BE NEEDED WITHIN 90 DAYS.
 - ② POST THE END OF CONSTRUCTION PROJECT SPEED LIMIT CONSISTING OF ONE SIGN WHEN THE NORMAL POSTED SPEED LIMIT FOR ALL VEHICLES IS THE SAME. USE TWO SIGNS WHEN CAR, TRUCK AND NIGHTTIME SPEED LIMITS ARE DIFFERENT.
 - ③ INCLUDE REGULATORY SIGNING ONLY IF THE CONSTRUCTION PROJECT CONTAINS A WORK ZONE OR HAS ROADWAY CONDITIONS THAT WARRANT SPEED RESTRICTIONS. MODIFY REGULATORY SIGNS TO MATCH ADJACENT REGULATIONS.
 - ④ THE WORK ZONE REFERS TO THE AREA WITHIN THE CONSTRUCTION PROJECT WHERE WORK IS ACTUALLY TAKING PLACE.
 - ⑤ IN ADDITION TO THE SIGNS SHOWN, INCLUDE THE APPROPRIATE TWO-LANE WORK ZONE SIGNS (DTL. DWG. NO. 618-08) WHEN A WORK ZONE IS LOCATED AT THE BEGINNING OR END OF THE CONSTRUCTION PROJECT.
 - ⑥ SET UP THIS SIGN LAYOUT IN EACH TRAFFIC DIRECTION.
- * DENOTES SIGNS THAT ARE UNIQUE TO MONTANA.

ALL DIMENSIONS ARE MILLIMETERS (mm) UNLESS OTHERWISE NOTED.

DETAILED DRAWING	
REFERENCE STANDARD SPEC. SECTION 618	DWG. NO. 618-04
TWO-LANE CONSTRUCTION PROJECT	
EFFECTIVE: APRIL 2006	

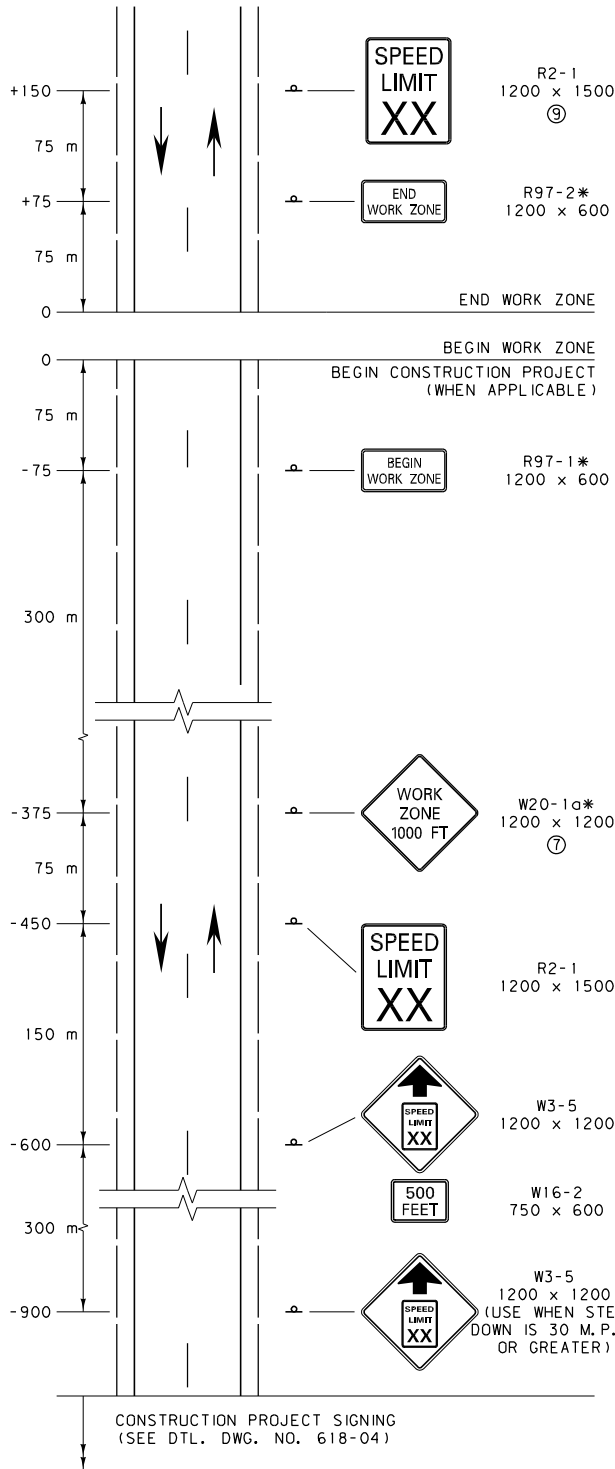

WORK ZONE WITH NO FLAGGER

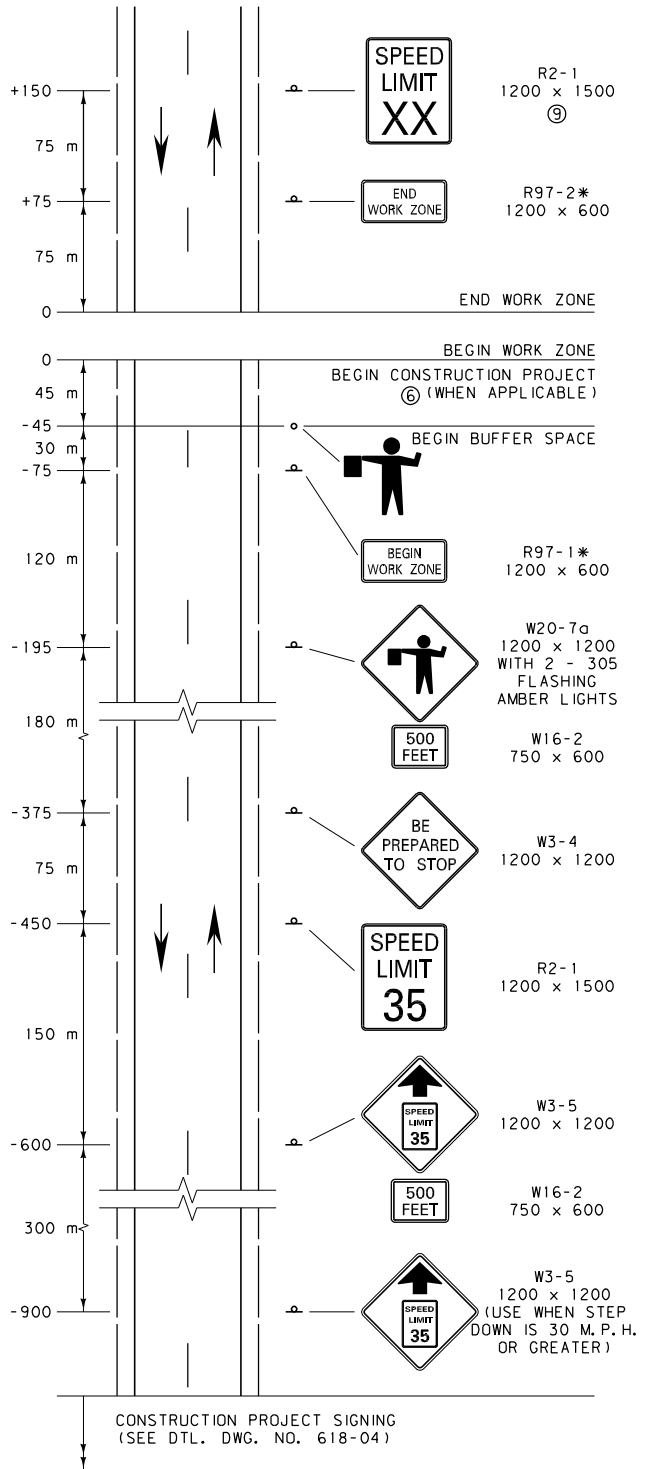

WORK ZONE WITH FLAGGER

NOTES:

- ① THESE SIGN LAYOUTS WORK IN CONJUNCTION WITH THE PERMANENT LAYOUT ILLUSTRATED ON DTL. DWG. NO. 618-04 FOR WORK ZONES LOCATED AT THE BEGIN AND END OF THE CONSTRUCTION PROJECT.
- ② XX = SPEED DETERMINED BY THE ENGINEER.
- ③ INCLUDE REGULATORY SIGNING ONLY IF THERE IS REASON TO RESTRICT SPEED WITHIN THE WORK ZONE. MODIFY REGULATORY SIGNS TO MATCH ADJACENT REGULATIONS.
- ④ SET UP THIS SIGN LAYOUT IN EACH TRAFFIC DIRECTION. COMBINE SUCCESSIVE WORK ZONES WHEN LESS THAN 1.6 KILOMETERS APART.
- ⑤ THE WORK ZONE REFERS TO THE AREA WITHIN THE CONSTRUCTION PROJECT WHERE WORK IS ACTUALLY TAKING PLACE.

- ⑥ THE BUFFER SPACE MAY BE INCREASED FOR DOWNGRADES AND OTHER CONDITIONS THAT AFFECT STOPPING DISTANCE.
- ⑦ USE MORE SPECIFIC SIGNS, WHERE APPLICABLE, SUCH AS W8-3 "PAVEMENT ENDS."
- ⑧ PROVIDE A SECOND FLAGGER WHEN REQUIRED BY STANDARD SPECIFICATIONS, SECTION 618.
- ⑨ POST THE END OF WORK ZONE SPEED LIMIT APPROPRIATE FOR ALL VEHICLES FOR THE REMAINDER OF THE CONSTRUCTION PROJECT BEFORE RESUMING TO NORMAL POSTED SPEED LIMITS AT THE END OF THE CONSTRUCTION PROJECT.

* DENOTES SIGNS THAT ARE UNIQUE TO MONTANA.

ALL DIMENSIONS ARE MILLIMETERS (mm) UNLESS OTHERWISE NOTED.

DETAILED DRAWING	
REFERENCE STANDARD SPEC. SECTION 618	DWG. NO. 618-08
TWO-LANE CONSTRUCTION PROJECT WORK ZONES	
EFFECTIVE: APRIL 2006	
 serving you with pride	MONTANA DEPARTMENT OF TRANSPORTATION

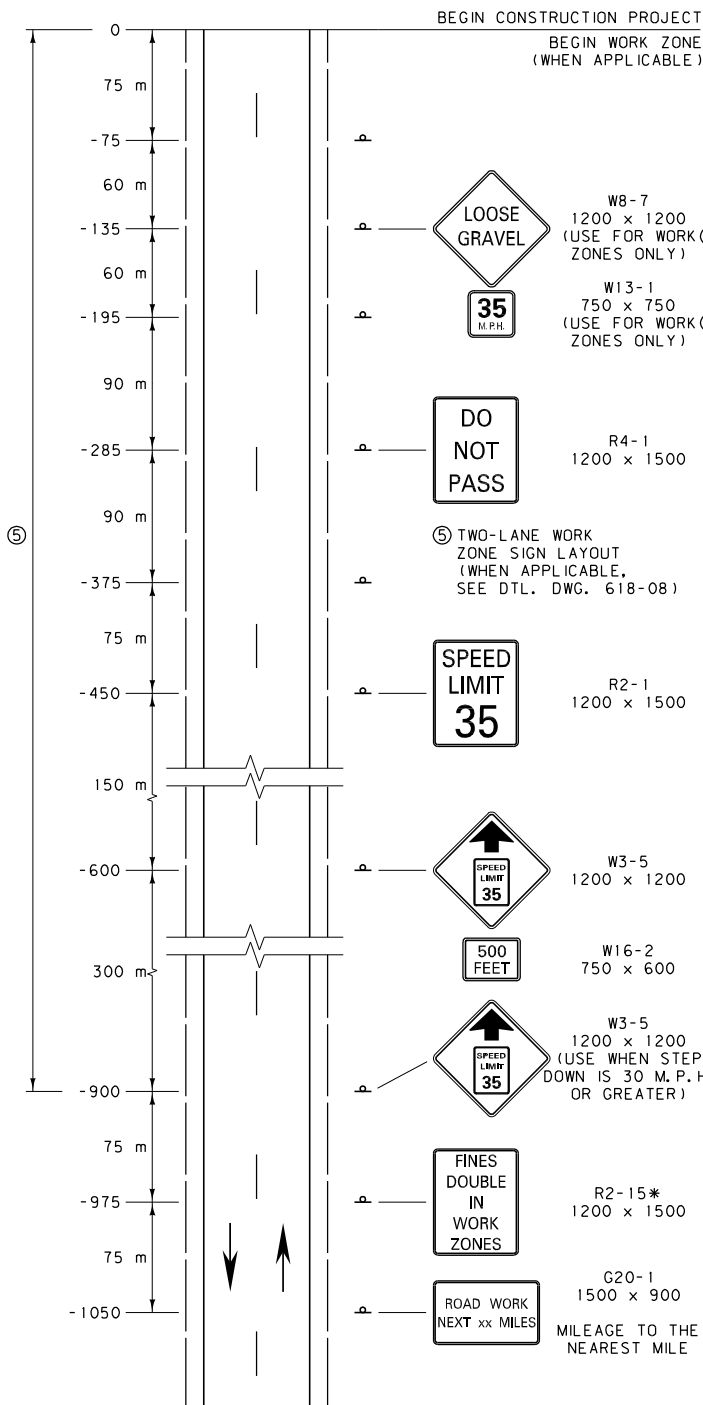
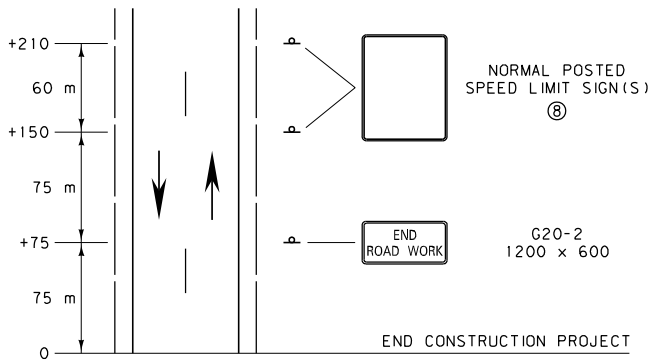

NOTES:

- ① THIS SIGN LAYOUT WORKS IN CONJUNCTION WITH THE PERMANENT LAYOUT ILLUSTRATED ON DTL. DWG. NO. 618-04. COVER OR REMOVE SIGNS WHEN NOT IN USE, INCLUDING SPEED LIMIT SIGNS NOT WARRANTED.
 - ② INCLUDE REGULATORY SIGNING ONLY IF THERE IS REASON TO RESTRICT SPEED WITHIN THE CONSTRUCTION PROJECT. MODIFY REGULATORY SIGNS TO MATCH ADJACENT REGULATIONS.
 - ③ THE WORK ZONE REFERS TO THE AREA WITHIN THE CONSTRUCTION PROJECT WHERE WORK IS ACTUALLY TAKING PLACE.
 - ④ FOR SEAL COAT WORK ZONE ACTIVITIES, USE THE FLAGGER APPLICATION OF THE WORK ZONE LAYOUT FROM DTL. DWG. NO. 618-08.
 - ⑤ IN ADDITION TO THE SIGNS SHOWN, INCLUDE THE APPROPRIATE TWO-LANE WORK ZONE SIGNS WHEN A WORK ZONE IS LOCATED AT THE BEGINNING OR END OF THE CONSTRUCTION PROJECT.
 - ⑥ SET UP THIS SIGN LAYOUT IN EACH TRAFFIC DIRECTION.
 - ⑦ PLACE THE W8-7 AND W13-1 SIGNS AT THE BEGINNING OF EACH WORK ZONE AND AT 3.2 km INTERVALS WITHIN THE WORK ZONES FOR EACH DIRECTION OF TRAVEL.
 - ⑧ POST THE END OF CONSTRUCTION PROJECT SPEED LIMIT CONSISTING OF ONE SIGN WHEN THE NORMAL POSTED SPEED LIMIT FOR ALL VEHICLES IS THE SAME. USE TWO SIGNS WHEN CAR, TRUCK AND NIGHTTIME SPEED LIMITS ARE DIFFERENT.
- * DENOTES SIGNS THAT ARE UNIQUE TO MONTANA.

ALL DIMENSIONS ARE MILLIMETERS (mm) UNLESS OTHERWISE NOTED.

DETAILED DRAWING	
REFERENCE STANDARD SPEC. SECTION 618	DWG. NO. 618-10
TWO-LANE CONSTRUCTION PROJECT SEAL COAT	

EFFECTIVE: APRIL 2006

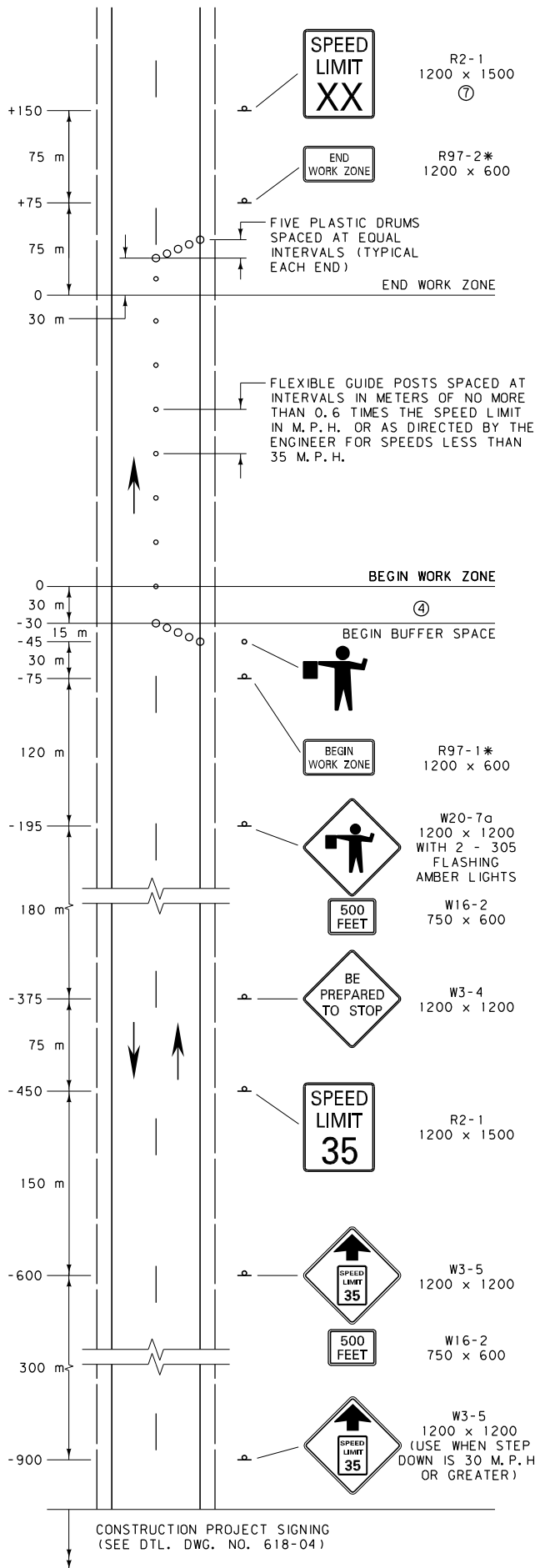

NOTES:

- ① MODIFY REGULATORY SIGNS TO MATCH ADJACENT REGULATIONS.
- ② SET UP THIS SIGN LAYOUT IN EACH TRAFFIC DIRECTION.
- ③ THE WORK ZONE REFERS TO THE AREA WITHIN THE CONSTRUCTION PROJECT WHERE WORK IS ACTUALLY TAKING PLACE.
- ④ THE BUFFER SPACE MAY BE INCREASED FOR DOWNGRADES AND OTHER CONDITIONS THAT AFFECT STOPPING DISTANCE.
- ⑤ PROVIDE A SECOND FLAGGER WHEN REQUIRED BY STANDARD SPECIFICATIONS, SECTION 618.
- ⑥ XX = SPEED DETERMINED BY THE ENGINEER.
- ⑦ POST THE END OF WORK ZONE SPEED LIMIT APPROPRIATE FOR ALL VEHICLES FOR THE REMAINDER OF THE CONSTRUCTION PROJECT BEFORE RESUMING TO NORMAL POSTED SPEED LIMITS AT THE END OF THE CONSTRUCTION PROJECT.

* DENOTES SIGNS THAT ARE UNIQUE TO MONTANA.

ALL DIMENSIONS ARE MILLIMETERS (mm) UNLESS OTHERWISE NOTED.

DETAILED DRAWING	
REFERENCE STANDARD SPEC. SECTION 618	DWG. NO. 618-12
TWO-LANE CONSTRUCTION PROJECT LANE CLOSURE - FLAGGER CONTROLLED	

EFFECTIVE: APRIL 2006

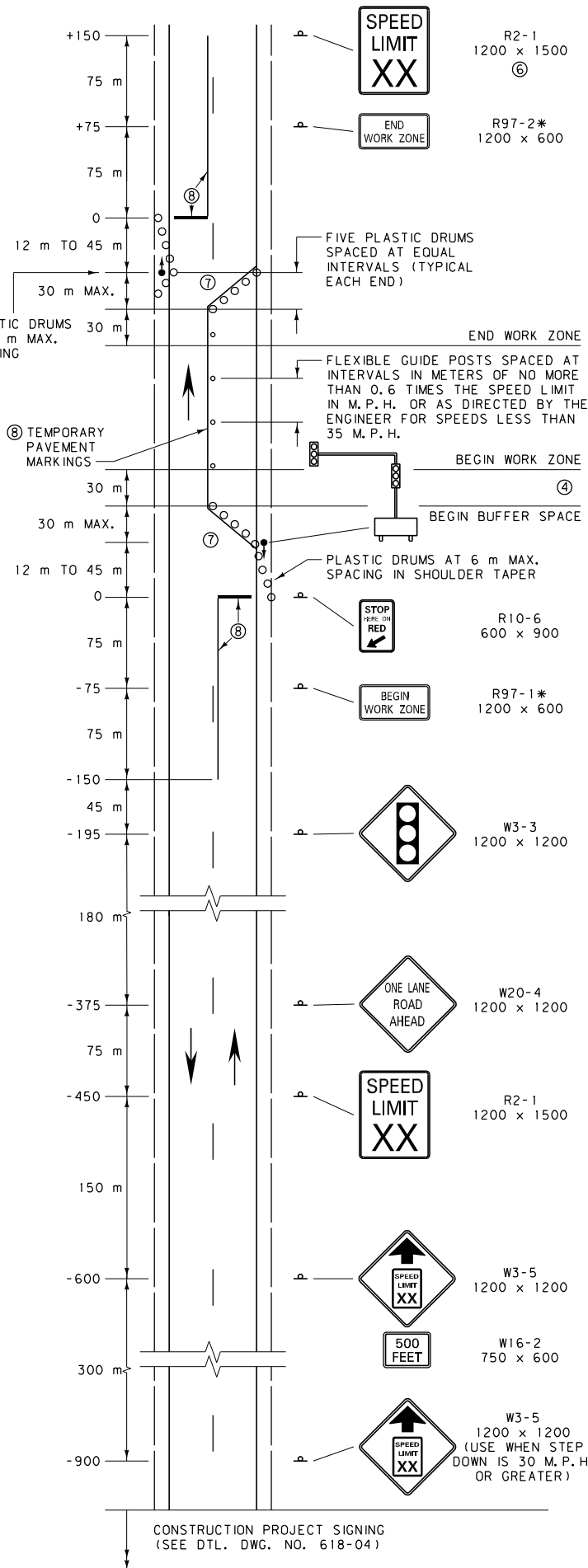

NOTES:

- ① MODIFY REGULATORY SIGNS TO MATCH ADJACENT REGULATIONS.
- ② SET UP THIS SIGN LAYOUT IN EACH TRAFFIC DIRECTION.
- ③ THE WORK ZONE REFERS TO THE AREA WITHIN THE CONSTRUCTION PROJECT WHERE WORK IS ACTUALLY TAKING PLACE.
- ④ THE BUFFER SPACE MAY BE INCREASED FOR DOWNGRADES AND OTHER CONDITIONS THAT AFFECT STOPPING DISTANCE.
- ⑤ XX = SPEED DETERMINED BY THE ENGINEER.
- ⑥ POST THE END OF WORK ZONE SPEED LIMIT APPROPRIATE FOR ALL VEHICLES FOR THE REMAINDER OF THE CONSTRUCTION PROJECT BEFORE RESUMING TO NORMAL POSTED SPEED LIMITS AT THE END OF THE CONSTRUCTION PROJECT.
- ⑦ REMOVE ANY CONFLICTING PAVEMENT MARKINGS BETWEEN THE STOP LINE AND WORK ZONE BOUNDARY.
- ⑧ PLACE TEMPORARY PAVEMENT MARKINGS AS SHOWN WHEN ROADWAY SURFACE IS PAVED. (REMOVABLE PAVEMENT MARKINGS MAY BE USED.) UPON REMOVAL OF THE TEMPORARY TRAFFIC CONTROL SIGNALS, REMOVE ALL TEMPORARY PAVEMENT MARKINGS AND RESTORE PERMANENT OR INTERIM PAVEMENT MARKINGS.
- ⑨ TEMPORARY TRAFFIC CONTROL SIGNALS ARE TO MEET THE PHYSICAL DISPLAY AND OPERATIONAL REQUIREMENTS OF PERMANENT TRAFFIC CONTROL SIGNALS.
- ⑩ ESTABLISH TEMPORARY TRAFFIC CONTROL SIGNAL TIMING BY CONSULTING WITH AN AUTHORIZED TRAFFIC ENGINEER. ENSURE THAT THE DURATIONS OF RED CLEARANCE INTERVALS ARE ADEQUATE TO CLEAR THE ONE-LANE SECTION OF CONFLICTING VEHICLES. INCORPORATE SAFEGUARDS TO AVOID THE POSSIBILITY OF CONFLICTING SIGNAL INDICATIONS AT EACH END OF THE WORK ZONE.
- ⑪ INCORPORATE ANY SIDE APPROACH TRAFFIC THAT OCCURS WITHIN THE WORK ZONE BOUNDARIES INTO THE MAINLINE SIGNAL CONTROLLED OPERATION VIA THE USE OF TEMPORARY TRAFFIC CONTROL SIGNS, DEVICES, ETC.

* DENOTES SIGNS THAT ARE UNIQUE TO MONTANA.

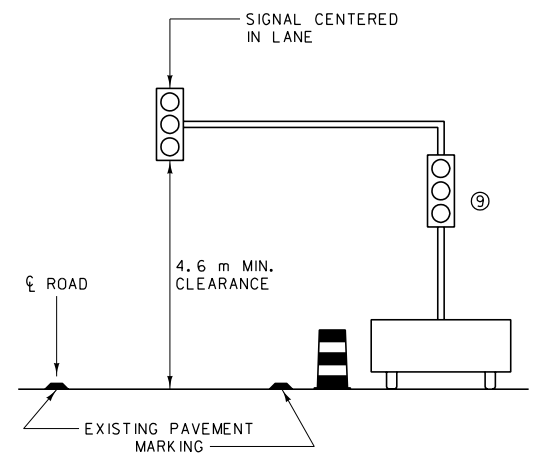

TEMPORARY TRAFFIC CONTROL SIGNAL DETAIL

ALL DIMENSIONS ARE MILLIMETERS (mm) UNLESS OTHERWISE NOTED.

DETAILED DRAWING	
REFERENCE STANDARD SPEC. SECTION 618	DWG. NO. 618-13
TWO-LANE CONSTRUCTION PROJECT LANE CLOSURE-SIGNAL CONTROLLED	

EFFECTIVE: APRIL 2006

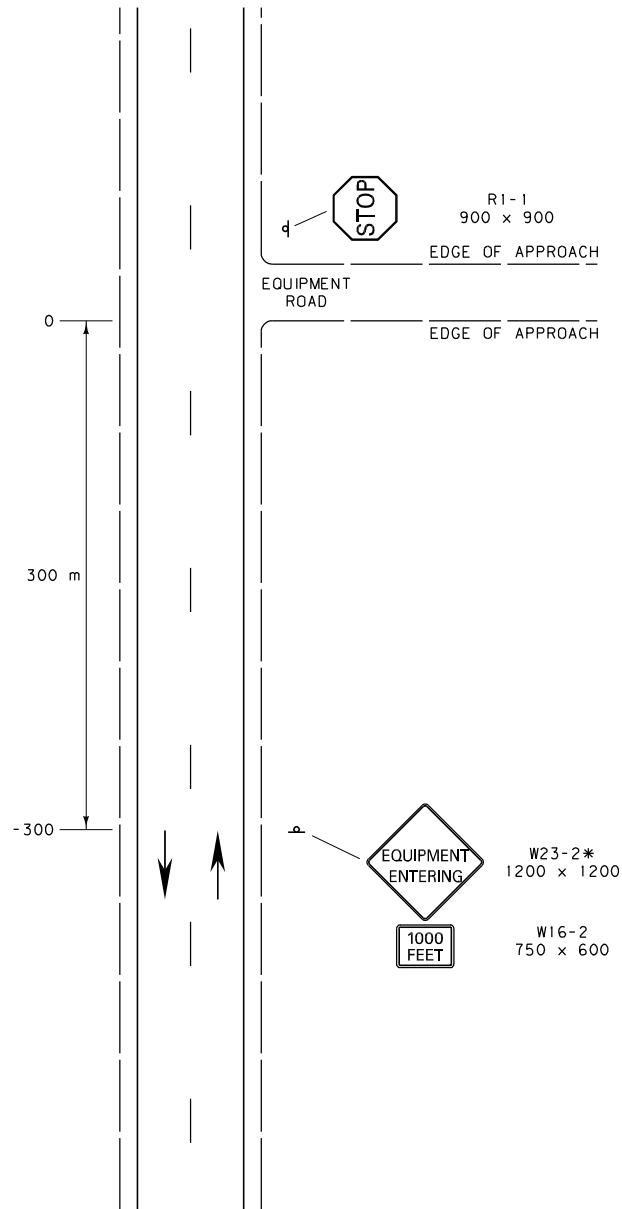

NOTES:

- ① USE THIS SIGN LAYOUT WHEN APPROPRIATE. OTHERWISE REFER TO DTL. DWG. NO. 618-16 WHEN A FLAGGER IS NEEDED.
 - ② SET UP THIS SIGN LAYOUT IN EACH TRAFFIC DIRECTION, AS NEEDED.
- * DENOTES SIGNS THAT ARE UNIQUE TO MONTANA.

ALL DIMENSIONS ARE MILLIMETERS (mm) UNLESS OTHERWISE NOTED.

DETAILED DRAWING	
REFERENCE STANDARD SPEC. SECTION 618	DWG. NO. 618-14
TWO-LANE EQUIPMENT ENTRANCES	
EFFECTIVE: FEBRUARY 2005	
 MONTANA DEPARTMENT OF TRANSPORTATION <i>servicing you with pride</i>	

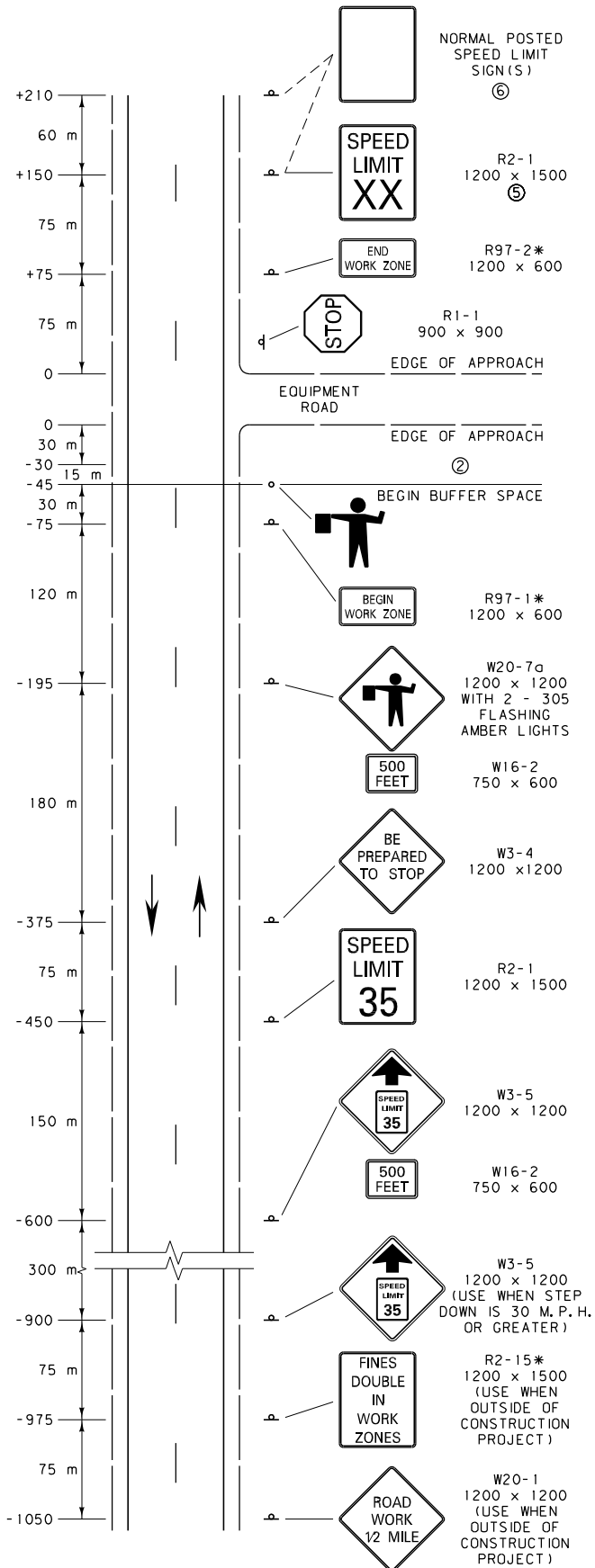

- NOTES:
- ① SET UP THIS SIGN LAYOUT IN EACH TRAFFIC DIRECTION, AS NEEDED.
 - ② THE BUFFER SPACE MAY BE INCREASED FOR DOWNGRADES AND OTHER CONDITIONS THAT AFFECT STOPPING DISTANCE.
 - ③ XX = SPEED DETERMINED BY THE ENGINEER.
 - ④ THE WORK ZONE REFERS TO THE AREA WHERE WORK IS ACTUALLY TAKING PLACE. WHEN THIS OCCURS OUTSIDE OF A CONSTRUCTION PROJECT INCLUDE THE W20-1 AND R2-15* SIGNS.
 - ⑤ POST THE END OF WORK ZONE SPEED LIMIT APPROPRIATE FOR ALL VEHICLES FOR THE REMAINDER OF THE CONSTRUCTION PROJECT BEFORE RESUMING TO NORMAL POSTED SPEED LIMITS AT THE END OF THE CONSTRUCTION PROJECT.
 - ⑥ WHEN OUTSIDE OF A CONSTRUCTION PROJECT, POST THE SPEED LIMIT CONSISTING OF ONE SIGN WHEN THE NORMAL POSTED SPEED LIMIT FOR ALL VEHICLES IS THE SAME. USE TWO SIGNS WHEN CAR, TRUCK AND NIGHTTIME SPEED LIMITS ARE DIFFERENT.
- * DENOTES SIGNS THAT ARE UNIQUE TO MONTANA.

EQUIPMENT ENTRANCE WITH FLAGGER

ALL DIMENSIONS ARE MILLIMETERS (mm) UNLESS OTHERWISE NOTED.

DETAILED DRAWING	
REFERENCE STANDARD SPEC. SECTION 618	DWG. NO. 618-16
TWO-LANE EQUIPMENT ENTRANCES	
EFFECTIVE: APRIL 2006	
MONTANA DEPARTMENT OF TRANSPORTATION <i>servicing you with pride</i>	

NOTES:

- ① INCLUDE REGULATORY SIGNING ONLY IF THERE IS REASON TO RESTRICT SPEED. MODIFY REGULATORY SIGNS TO MATCH ADJACENT REGULATIONS.
 - ② SET UP THIS SIGN LAYOUT IN EACH TRAFFIC DIRECTION.
 - ③ PAVED DETOURS 7.2 m WIDE OR GREATER HAVE 100 mm WHITE SHOULDER STRIPES AND APPROPRIATE CENTERLINE STRIPES.
 - ④ UNPAVED DETOURS MAY REQUIRE ADDITIONAL DELINEATION.
 - ⑤ USE ONLY POST MOUNTED SIGNS. DO NOT USE PORTABLE SIGN MOUNTS.
 - ⑥ PLACE PLASTIC DRUMS AT INTERVALS IN METERS OF NO MORE THAN 0.3 TIMES THE SPEED LIMIT IN M.P.H. OR AS DIRECTED BY THE ENGINEER FOR SPEEDS LESS THAN 35 M.P.H.
 - ⑦ XX = SPEED DETERMINED BY THE DETOUR DESIGN SPEED OR THE ENGINEER.
 - ⑧ THE WORK ZONE REFERS TO THE AREA WITHIN THE CONSTRUCTION PROJECT WHERE WORK IS ACTUALLY TAKING PLACE.
 - ⑨ USE MATERIALS FOR BARRICADE FRAMEWORK AND ASSEMBLY, INCLUDING ANY SIGNS AND MEANS OF ATTACHMENT, THAT MEET THE REQUIREMENTS FOR NCHRP 350 FOR WORK ZONE DEVICES. ALTERNATIVELY, SIGNS ON BARRICADES MAY BE MOUNTED DIRECTLY BEHIND BARRICADES ON SEPARATE SIGN SUPPORTS.
 - ⑩ POST THE END OF WORK ZONE SPEED LIMIT APPROPRIATE FOR ALL VEHICLES FOR THE REMAINDER OF THE CONSTRUCTION PROJECT BEFORE RESUMING TO NORMAL POSTED SPEED LIMITS AT THE END OF THE CONSTRUCTION PROJECT.
- * DENOTES SIGNS THAT ARE UNIQUE TO MONTANA.

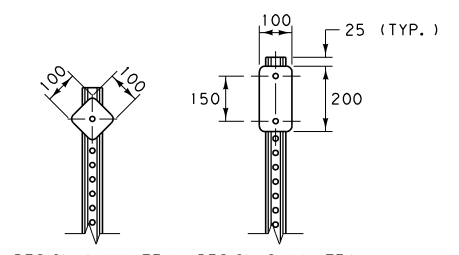

DELINEATOR LEGEND	
	DESIGN A
	DESIGN G

- Ⓐ USE THE W1-4 AND W1-3 SIGNS WHEN THE TANGENT DISTANCE ALONG THE DETOUR IS MORE THAN 180 m.
- Ⓑ USE W1-3 SIGNS ONLY WHEN THE DESIGN SPEED OF THE CURVES IS 50 km/hr (30 M.P.H.) OR LESS.
- Ⓒ INCLUDE THE BEGIN AND END WORK ZONE SIGNS IF A WORK ZONE OCCURS EXCLUSIVELY ON THE DETOUR.

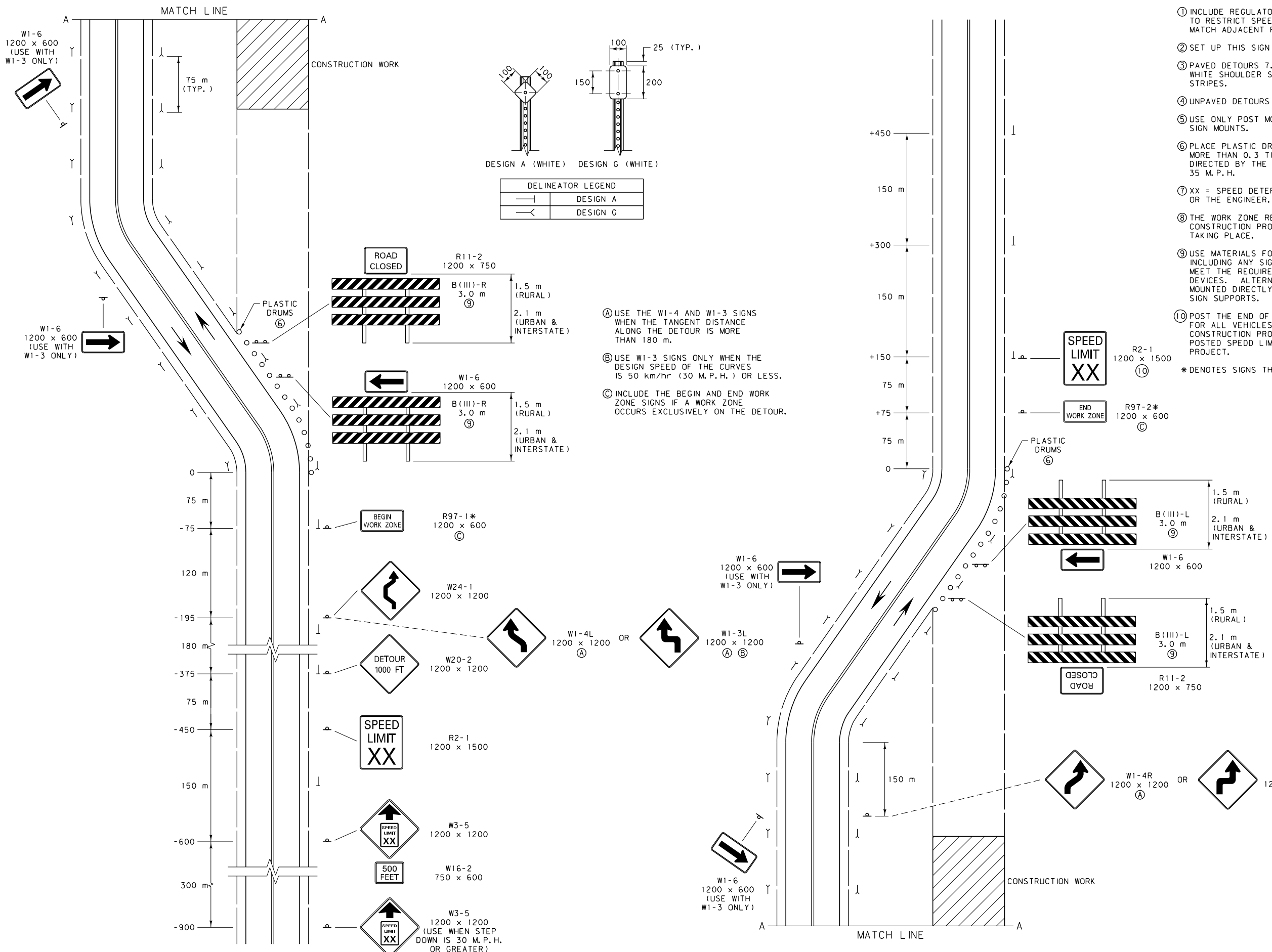

ALL DIMENSIONS ARE MILLIMETERS (mm) UNLESS OTHERWISE NOTED.

DETAILED DRAWING	
REFERENCE STANDARD SPEC. SECTION 618	DWG. NO. 618-18
TWO-LANE CONSTRUCTION PROJECT DETOUR	
EFFECTIVE: APRIL 2006	
MONTANA DEPARTMENT OF TRANSPORTATION <i>servicing you with pride</i>	

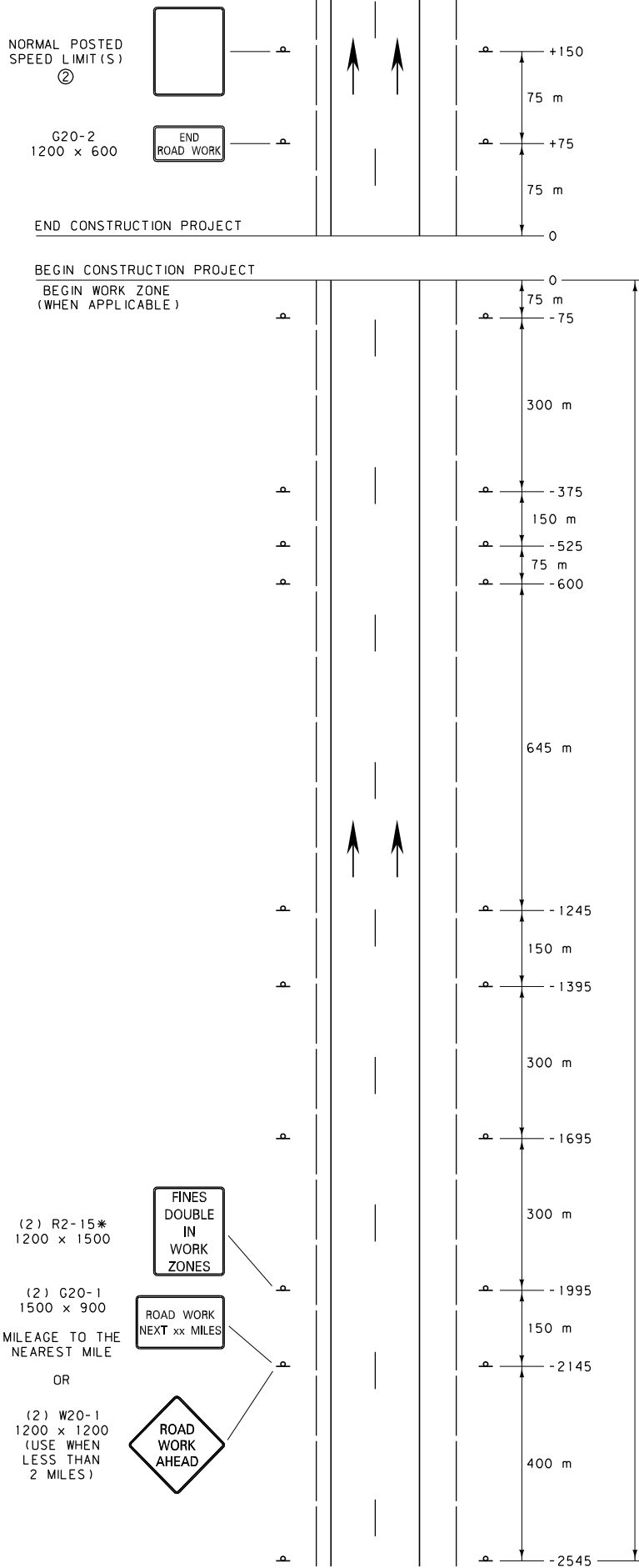

NOTES:

- ① THIS SIGN LAYOUT IS INTENDED TO BE A PERMANENT INSTALLATION FOR THE DURATION OF THE CONSTRUCTION PROJECT, AS APPROVED BY THE ENGINEER. COVER OR REMOVE SIGNS WHEN NOT IN USE, INCLUDING SPEED LIMIT SIGNS NOT WARRANTED. REMOVE ANY SIGN SUPPORTS IF THEY WILL NOT BE NEEDED WITHIN 90 DAYS.
- ② POST THE END OF CONSTRUCTION PROJECT SPEED LIMIT CONSISTING OF ONE LIMIT WHEN THE NORMAL POSTED SPEED LIMIT FOR ALL VEHICLES IS THE SAME. WHEN CAR AND TRUCK SPEED LIMITS DIFFER, POST BOTH LIMITS ON A SINGLE SIGN.
- ③ INCLUDE REGULATORY SIGNING ONLY IF THE CONSTRUCTION PROJECT CONTAINS A WORK ZONE OR HAS ROADWAY CONDITIONS THAT WARRANT SPEED RESTRICTIONS. MODIFY REGULATORY SIGNS TO MATCH ADJACENT REGULATIONS.
- ④ THE WORK ZONE REFERS TO THE AREA WITHIN THE CONSTRUCTION PROJECT WHERE WORK IS ACTUALLY TAKING PLACE.
- ⑤ SET UP THIS SIGN LAYOUT IN EACH TRAFFIC DIRECTION.
- ⑥ IN ADDITION TO THE SIGNS SHOWN, INCLUDE THE APPROPRIATE FOUR-LANE WORK ZONE SIGNS (DTL. DWG. NO. 618-24) WHEN A WORK ZONE FALLS AT THE BEGIN OR END OF THE CONSTRUCTION PROJECT.
- ⑦ DIVIDED FOUR-LANE IS SHOWN. FOR UN-DIVIDED FOUR-LANE, PLACE SIGNS ON RIGHT SIDE ONLY.

* DENOTES SIGNS THAT ARE UNIQUE TO MONTANA.

FOUR-LANE WORK ZONE SIGN LAYOUT (WHEN APPLICABLE, SEE DTL. DWG. 618-24) ⑥

ALL DIMENSIONS ARE MILLIMETERS (mm) UNLESS OTHERWISE NOTED.

DETAILED DRAWING	
REFERENCE STANDARD SPEC. SECTION 618	DWG. NO. 618-20
DIVIDED FOUR-LANE CONSTRUCTION PROJECT	
EFFECTIVE: APRIL 2006	
MONTANA DEPARTMENT OF TRANSPORTATION <i>servicing you with pride</i>	

MATCH LINE FROM
DTL. DWG. NO. 618-30

NOTES:

- ① SPACE CHANNELIZING DEVICES ON TANGENTS AT INTERVALS IN METERS OF NO MORE THAN 0.6 TIMES THE SPEED LIMIT IN M.P.H. AND ON ALL TAPER SECTIONS AT INTERVALS IN METERS OF NO MORE THAN 0.3 TIMES THE SPEED LIMIT IN M.P.H. FOR SPEED LIMITS LESS THAN 35 M.P.H. SPACE CHANNELIZING DEVICES AS DIRECTED BY THE ENGINEER.
- ② OBLITERATE ALL PAVEMENT MARKINGS THAT CONFLICT AT ANY TIME DURING OR AFTER MEDIAN CROSSING USE.
- ③ INDICATED SPACINGS ARE INTENDED TO BE A MAXIMUM AND MAY BE REDUCED IF CONDITIONS WARRANT.
- ④ USE MATERIALS FOR BARRICADE FRAMEWORK AND ASSEMBLY, INCLUDING ANY SIGNS AND MEANS OF ATTACHMENT, THAT MEET THE REQUIREMENTS FOR NCHRP 350 FOR WORK ZONE DEVICES. ALTERNATIVELY, SIGNS ON BARRICADES MAY BE MOUNTED DIRECTLY BEHIND BARRICADES ON SEPARATE SIGN SUPPORTS.

FLEXIBLE GLUE
DOWN GUIDE
POSTS SPACED
AT HALF NORMAL
SPACING

R3-2
900 x 900



30 m

300 m

150 m
MERGING
LANE

150 m
ACCELERATION
LANE

WHITE



W4-1
1200 x 1200

75 m



R5-1
900 x 900

75 m

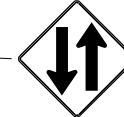

W6-3
1200 x 1200

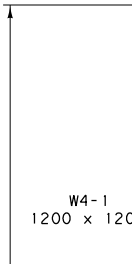

W4-1
1200 x 1200



R5-1a
900 x 600
(ANGLE 20° TOWARDS
CROSS-OVER LANE)

10:1 TAPER
(DESIRABLE)
8:1 TAPER
(MINIMUM)

YELLOW

ROAD
CLOSED

R11-2
1200 x 750

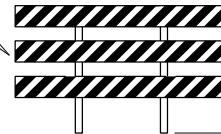

B(III)-R
3.0 m
④
1.5 m
(RURAL)
2.1 m
(URBAN &
INTERSTATE)

R3-2
900 x 900



75 m



W6-3
1200 x 1200

W16-9P
750 x 450



W20-1
1200 x 1200

150 m

LEGEND

- OBLITERATE CONFLICTING PAVEMENT MARKINGS AND FILL ANY EXISTING RUMBLE STRIPS WITH PMS
- PLASTIC DRUMS (SEE NOTES FOR SPACING)
- - - - - RAISED RIGID PAVEMENT MARKERS TYPE I OR II AT 1.5 m SPACING
- ==== DOUBLE YELLOW PAINT OR DOUBLE PLASTIC PAVEMENT MARKING TABS AT 1.5 m SPACING
- FLEXIBLE GLUE-DOWN GUIDE POSTS ON TWO-LANE (SEE NOTES FOR SPACING EXCEPT AS SHOWN)

ALL DIMENSIONS ARE MILLIMETERS
(mm) UNLESS OTHERWISE NOTED.

DETAILED DRAWING	
REFERENCE STANDARD SPEC. SECTION 618	DWG. NO. 618-21
TEMPORARY ENTRANCE RAMP MEDIAN CROSSING	
EFFECTIVE: APRIL 2006	
MONTANA DEPARTMENT OF TRANSPORTATION serving you with pride	

LEGEND

- OBLITERATE CONFLICTING PAVEMENT MARKINGS AND FILL ANY EXISTING RUMBLE STRIPS WITH PMS
- PLASTIC DRUMS (SEE NOTES FOR SPACING)
- - - - - RAISED RIGID PAVEMENT MARKERS TYPE I OR II AT 1.5 m SPACING
- ==== DOUBLE YELLOW PAINT OR DOUBLE PLASTIC PAVEMENT MARKING TABS AT 1.5 m SPACING
- FLEXIBLE GLUE-DOWN GUIDE POSTS ON TWO-LANE (SEE NOTES FOR SPACING EXCEPT AS SHOWN)

E5-1
1500 x 1200



R3-2
900 x 900



FLEXIBLE GLUE
DOWN GUIDE
POSTS SPACED
AT HALF NORMAL
SPACING

W6-3
1200 x 1200



E7-1
1800 x 900

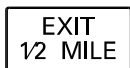

YELLOW

WHITE

10: 1 TAPER
(DESIRABLE)

8: 1 TAPER
(MINIMUM)

NOTES:

- ① SPACE CHANNELIZING DEVICES ON TANGENTS AT INTERVALS IN METERS OF NO MORE THAN 0.6 TIMES THE SPEED LIMIT IN M.P.H. AND ON ALL TAPER SECTIONS AT INTERVALS IN METERS OF NO MORE THAN 0.3 TIMES THE SPEED LIMIT IN M.P.H. FOR SPEED LIMITS LESS THAN 35 M.P.H., SPACE CHANNELIZING DEVICES AS DIRECTED BY THE ENGINEER.
- ② OBLITERATE ALL PAVEMENT MARKINGS THAT CONFLICT AT ANY TIME DURING OR AFTER MEDIAN CROSSING USE.
- ③ INDICATED SPACINGS ARE INTENDED TO BE A MAXIMUM AND MAY BE REDUCED IF CONDITIONS WARRANT.
- ④ PROVIDE ADDITIONAL SIGNING FOR EXIT DESTINATION WHEN EXIT DELINIATION IS NOT VISIBLE.
- ⑤ USE MATERIALS FOR BARRICADE FRAMEWORK AND ASSEMBLY, INCLUDING ANY SIGNS AND MEANS OF ATTACHMENT, THAT MEET THE REQUIREMENTS FOR NCHRP 350 FOR WORK ZONE DEVICES. ALTERNATIVELY, SIGNS ON BARRICADES MAY BE MOUNTED DIRECTLY BEHIND BARRICADES ON SEPARATE SIGN SUPPORTS.

ALL DIMENSIONS ARE MILLIMETERS (mm) UNLESS OTHERWISE NOTED.

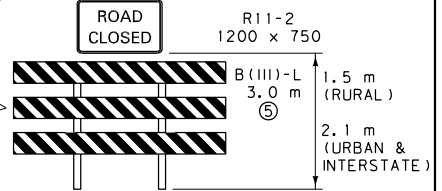

DETAILED DRAWING	
REFERENCE STANDARD SPEC. SECTION 618	DWG. NO. 618-22
TEMPORARY EXIT RAMP MEDIAN CROSSING	
EFFECTIVE: APRIL 2006	

NOTE:
THIS SEQUENCE OF SIGNS IS IDENTICAL FOR BOTH WORK ZONES SHOWN ON THIS DETAIL.

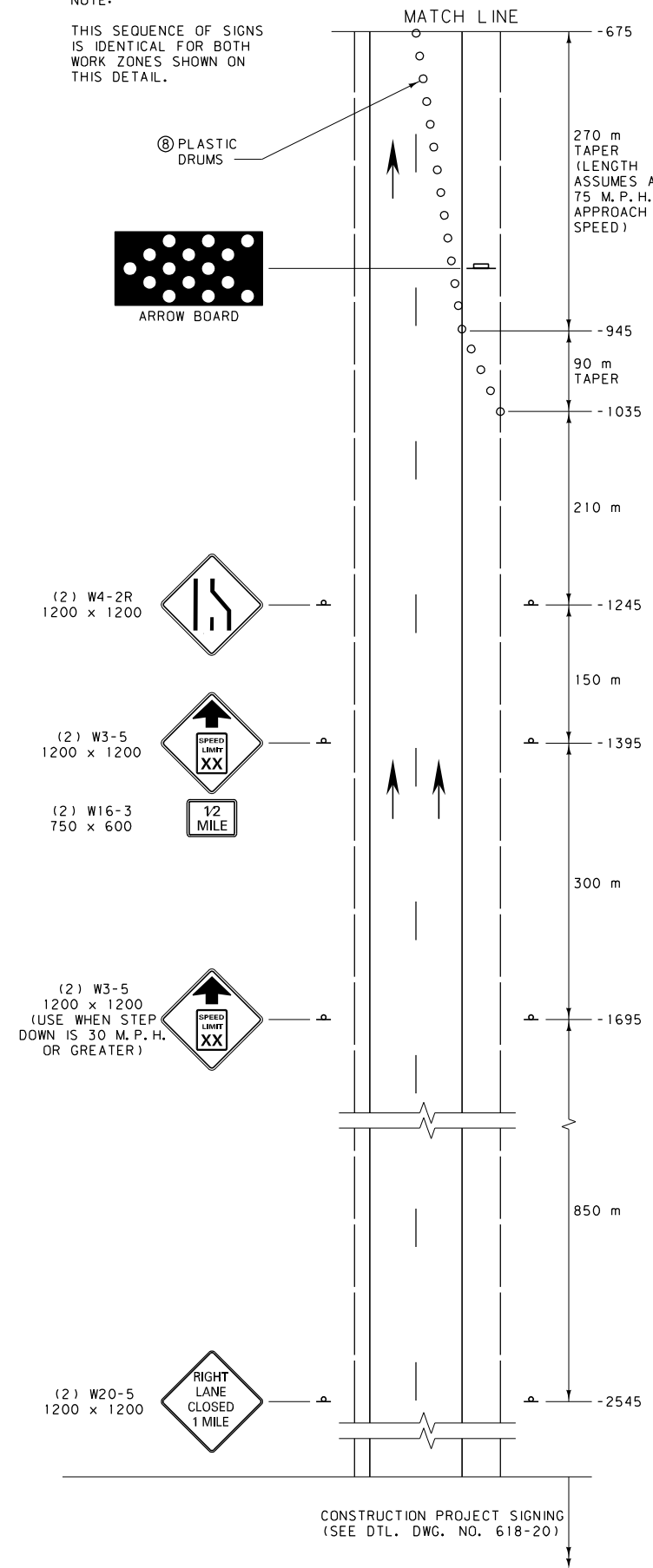

CONSTRUCTION PROJECT SIGNING
(SEE DTL. DWG. NO. 618-20)

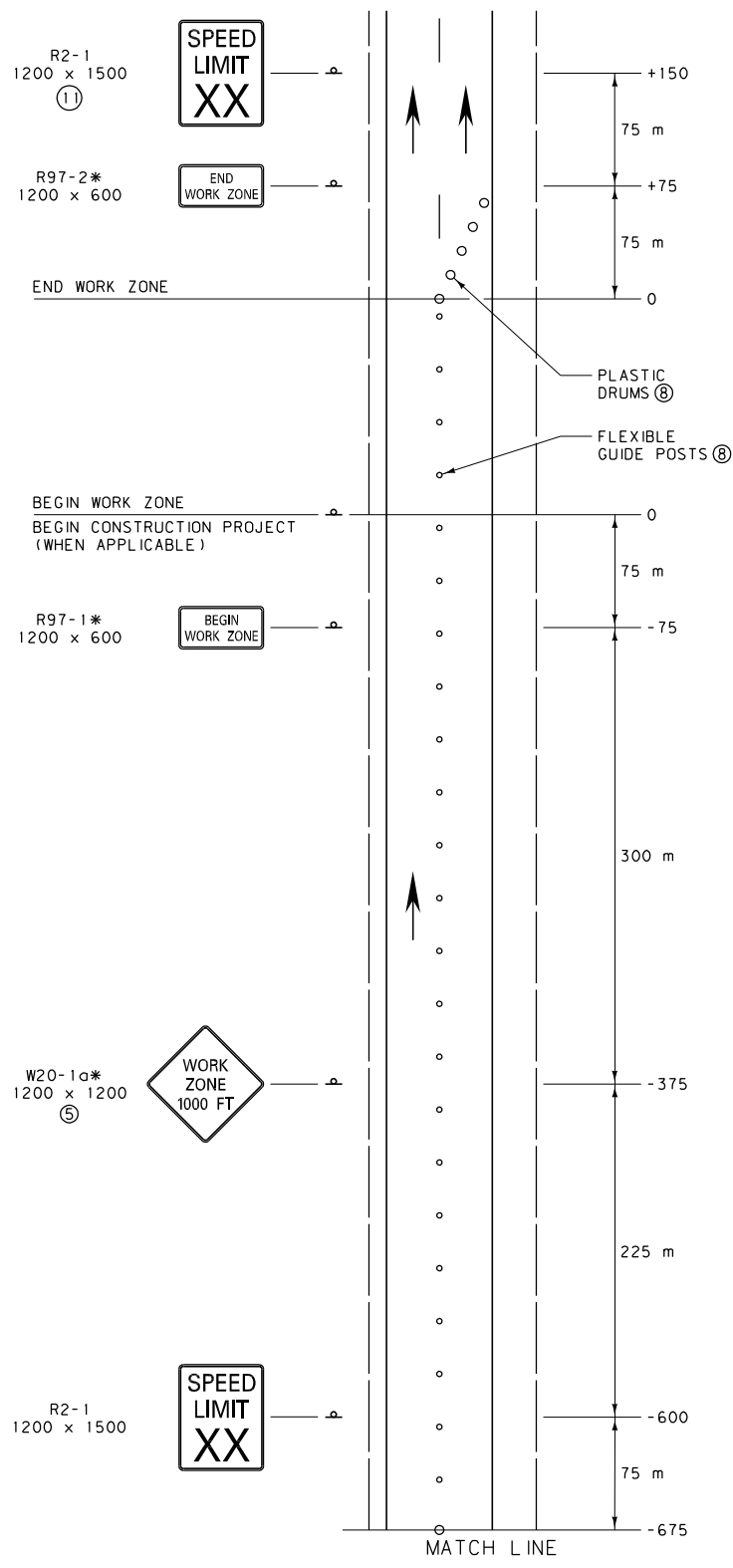

WORK ZONE WITH NO FLAGGER

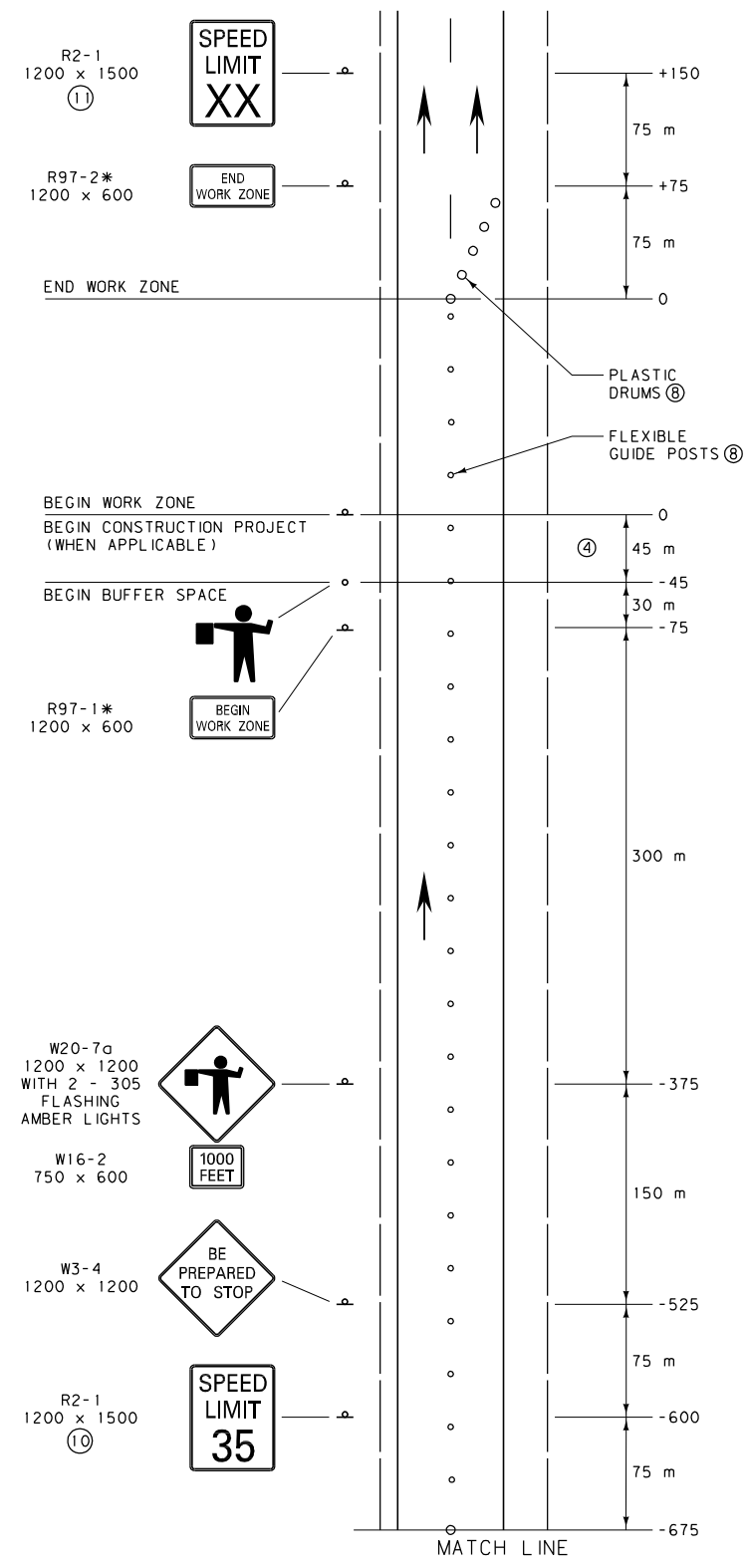

WORK ZONE WITH FLAGGER

- NOTES:
- ① THESE SIGN LAYOUTS WORK IN CONJUNCTION WITH THE PERMANENT LAYOUT ILLUSTRATED ON DTL. DWG. NO. 618-20 FOR WORK ZONES LOCATED AT THE BEGIN AND END OF THE CONSTRUCTION PROJECT.
 - ② INCLUDE REGULATORY SIGNING ONLY IF THERE IS REASON TO RESTRICT SPEED WITHIN THE WORK ZONE. MODIFY REGULATORY SIGNS TO MATCH ADJACENT REGULATIONS.
 - ③ THE WORK ZONE REFERS TO THE AREA WITHIN THE CONSTRUCTION PROJECT WHERE WORK IS ACTUALLY TAKING PLACE.
 - ④ THE BUFFER SPACE MAY BE INCREASED FOR DOWNGRADES AND OTHER CONDITIONS THAT AFFECT STOPPING DISTANCE.
 - ⑤ USE MORE SPECIFIC SIGNS, WHERE APPLICABLE, SUCH AS W8-3 "PAVEMENT ENDS."
 - ⑥ XX = SPEED DETERMINED BY THE ENGINEER.
 - ⑦ PROVIDE A SECOND FLAGGER WHEN REQUIRED BY STANDARD SPECIFICATIONS, SECTION 618.
 - ⑧ SPACE FLEXIBLE GUIDE POSTS ON TANGENTS AT INTERVALS IN METERS OF NO MORE THAN 0.6 TIMES THE SPEED LIMIT IN M. P. H. SPACE PLASTIC DRUMS IN ALL TAPER SECTIONS AT INTERVALS IN METERS OF NO MORE THAN 0.3 TIMES THE SPEED LIMIT IN M. P. H. FOR SPEED LIMITS LESS THAN 35 M. P. H., SPACE CHANNELIZING DEVICES AS DIRECTED BY THE ENGINEER.
 - ⑨ WHEN PORTABLE SIGNS ARE USED, PLACE AS DIRECTED BY THE ENGINEER.
 - ⑩ IF FLAGGER IS MORE THAN 1.6 km FROM THE LANE CLOSURE, INCLUDE W3-5 SIGNS, AS REQUIRED.
 - ⑪ POST THE END OF WORK ZONE SPEED LIMIT APPROPRIATE FOR ALL VEHICLES FOR THE REMAINDER OF THE CONSTRUCTION PROJECT BEFORE RESUMING TO NORMAL POSTED SPEED LIMITS AT THE END OF THE CONSTRUCTION PROJECT.

* DENOTES SIGNS THAT ARE UNIQUE TO MONTANA.

ALL DIMENSIONS ARE MILLIMETERS (mm) UNLESS OTHERWISE NOTED.

DETAILED DRAWING	
REFERENCE STANDARD SPEC. SECTION 618	DWG. NO. 618-24
DIVIDED FOUR-LANE CONSTRUCTION PROJECT WORK ZONES	
EFFECTIVE: APRIL 2006	
	MONTANA DEPARTMENT OF TRANSPORTATION

NOTE:
THIS SEQUENCE OF SIGNS IS IDENTICAL FOR BOTH WORK ZONES SHOWN ON THIS DETAIL.

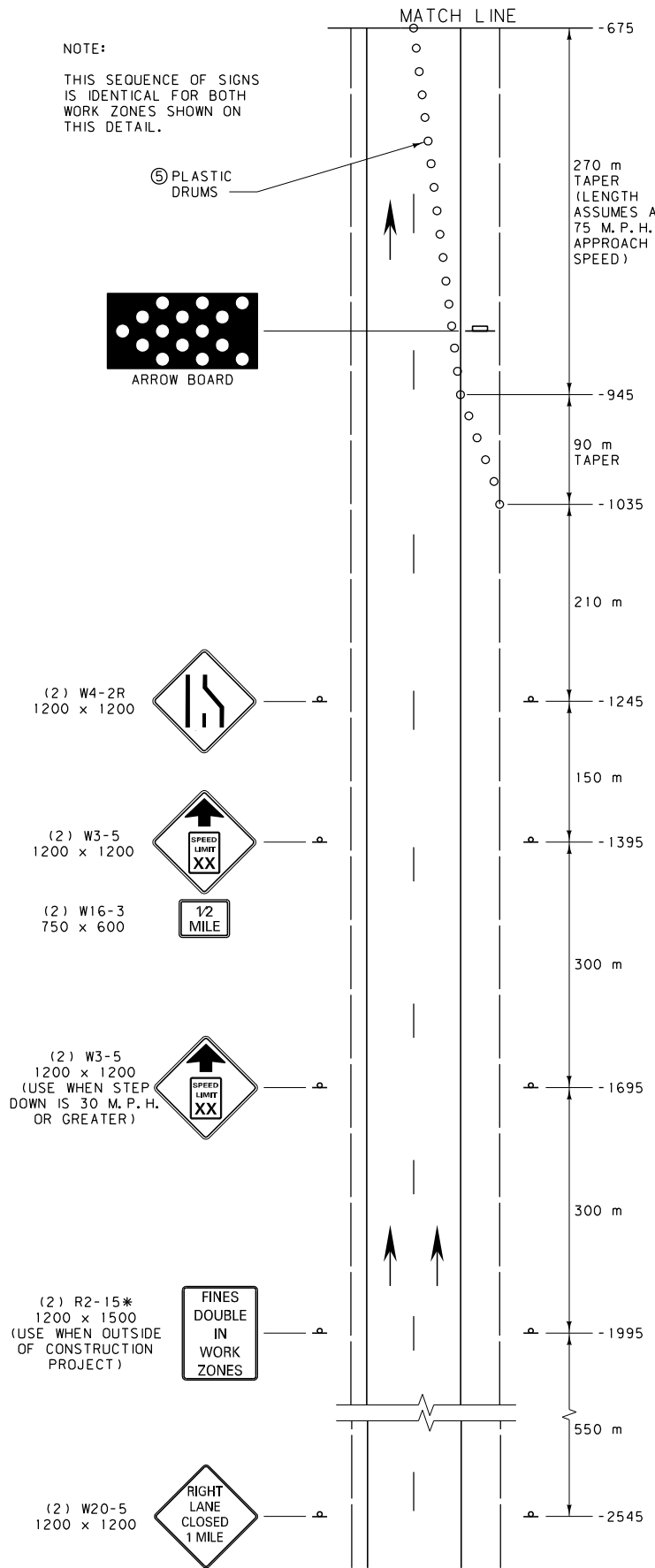

NORMAL POSTED SPEED LIMIT(S)

- ⑧
- OR
- R2-1
1200 x 1500
- ⑦
- R97-2*
1200 x 600

⑤ FLEXIBLE GUIDE POSTS SPACED AT HALF NORMAL SPACING

R97-1*
1200 x 600

3 PLASTIC DRUMS

⑤ FLEXIBLE GUIDE POSTS

W23-2*
1200 x 1200

W16-2
750 x 600

R2-1
1200 x 1500

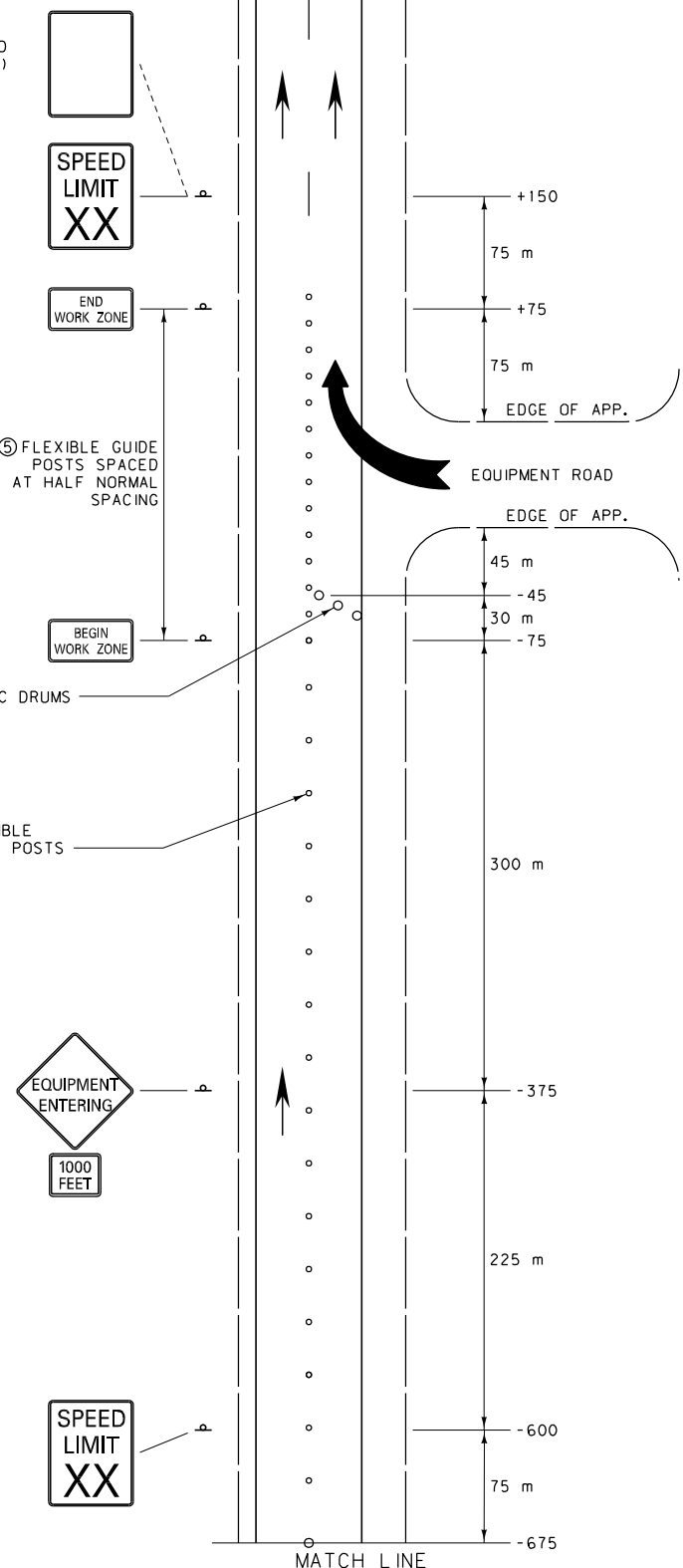

EQUIPMENT ENTRANCE WITH NO FLAGGER

NORMAL POSTED SPEED LIMIT(S)

- ⑧
- OR
- R2-1
1200 x 1500
- ⑦
- R97-2*
1200 x 600

BEGIN BUFFER SPACE

R97-1*
1200 x 600

3 PLASTIC DRUMS

⑤ FLEXIBLE GUIDE POSTS

W20-7a
1200 x 1200 WITH 2 - 305 FLASHING AMBER LIGHTS

W16-2
750 x 600

W3-4
1200 x 1200

R2-1
1200 x 1500

⑥

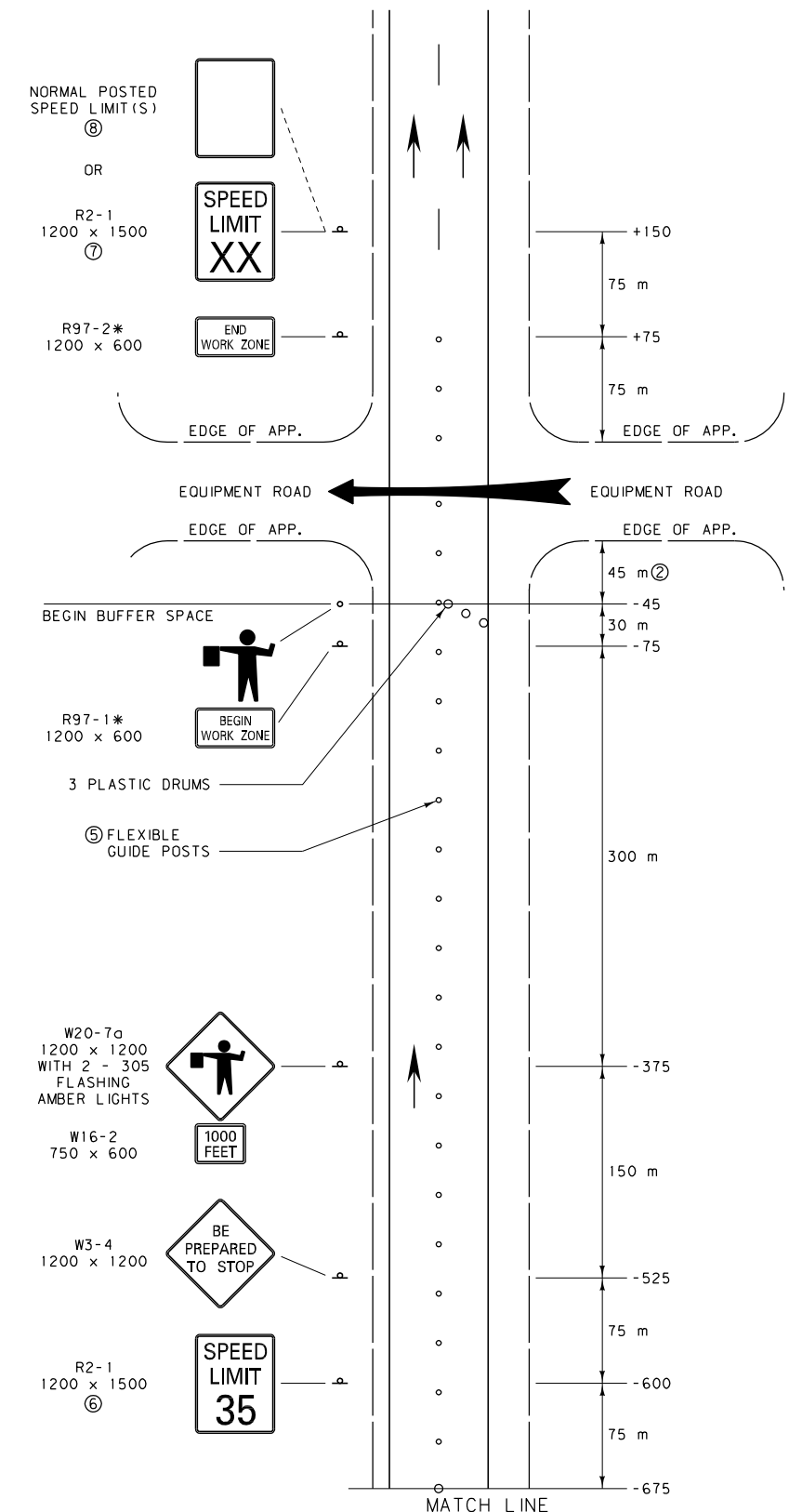

EQUIPMENT ENTRANCE WITH FLAGGER

- NOTES:
- ① INCLUDE REGULATORY SIGNING ONLY IF THERE IS REASON TO RESTRICT SPEED WITHIN THE WORK ZONE. MODIFY REGULATORY SIGNS TO MATCH ADJACENT REGULATIONS.
 - ② THE BUFFER SPACE MAY BE INCREASED FOR DOWNGRADES AND OTHER CONDITIONS THAT AFFECT STOPPING DISTANCE.
 - ③ XX = SPEED DETERMINED BY THE ENGINEER.
 - ④ THE WORK ZONE REFERS TO THE AREA WHERE WORK IS ACTUALLY TAKING PLACE. WHEN THIS OCCURS OUTSIDE OF A CONSTRUCTION PROJECT, INCLUDE THE R2-15* SIGN.
 - ⑤ SPACE FLEXIBLE GUIDE POSTS ON TANGENTS AT INTERVALS IN METERS OF NO MORE THAN 0.6 TIMES THE SPEED LIMIT IN M.P.H. SPACE PLASTIC DRUMS IN ALL TAPER SECTIONS AT INTERVALS IN METERS OF NO MORE THAN 0.3 TIMES THE SPEED LIMIT IN M.P.H. FOR SPEED LIMITS LESS THAN 35 M.P.H., SPACE CHANNELIZING DEVICES AS DIRECTED BY THE ENGINEER.
 - ⑥ IF FLAGGER IS MORE THAN 1.6 km FROM THE LANE CLOSURE, INCLUDE W3-5 SIGNS, AS REQUIRED.
 - ⑦ POST THE END OF WORK ZONE SPEED LIMIT APPROPRIATE FOR ALL VEHICLES FOR THE REMAINDER OF THE CONSTRUCTION PROJECT BEFORE RESUMING TO NORMAL POSTED SPEED LIMITS AT THE END OF THE CONSTRUCTION PROJECT.
 - ⑧ WHEN OUTSIDE OF A CONSTRUCTION PROJECT, POST THE SPEED LIMIT CONSISTING OF ONE LIMIT WHEN THE NORMAL POSTED SPEED LIMIT FOR ALL VEHICLES IS THE SAME. WHEN CAR AND TRUCK SPEED LIMITS DIFFER, POST BOTH LIMITS ON A SINGLE SIGN.
- * DENOTES SIGNS THAT ARE UNIQUE TO MONTANA.

ALL DIMENSIONS ARE MILLIMETERS (mm) UNLESS OTHERWISE NOTED.

DETAILED DRAWING	
REFERENCE STANDARD SPEC. SECTION 618	DWG. NO. 618-27
DIVIDED FOUR-LANE EQUIPMENT ENTRANCES	
EFFECTIVE: APRIL 2006	
MONTANA DEPARTMENT OF TRANSPORTATION <i>servicing you with pride</i>	

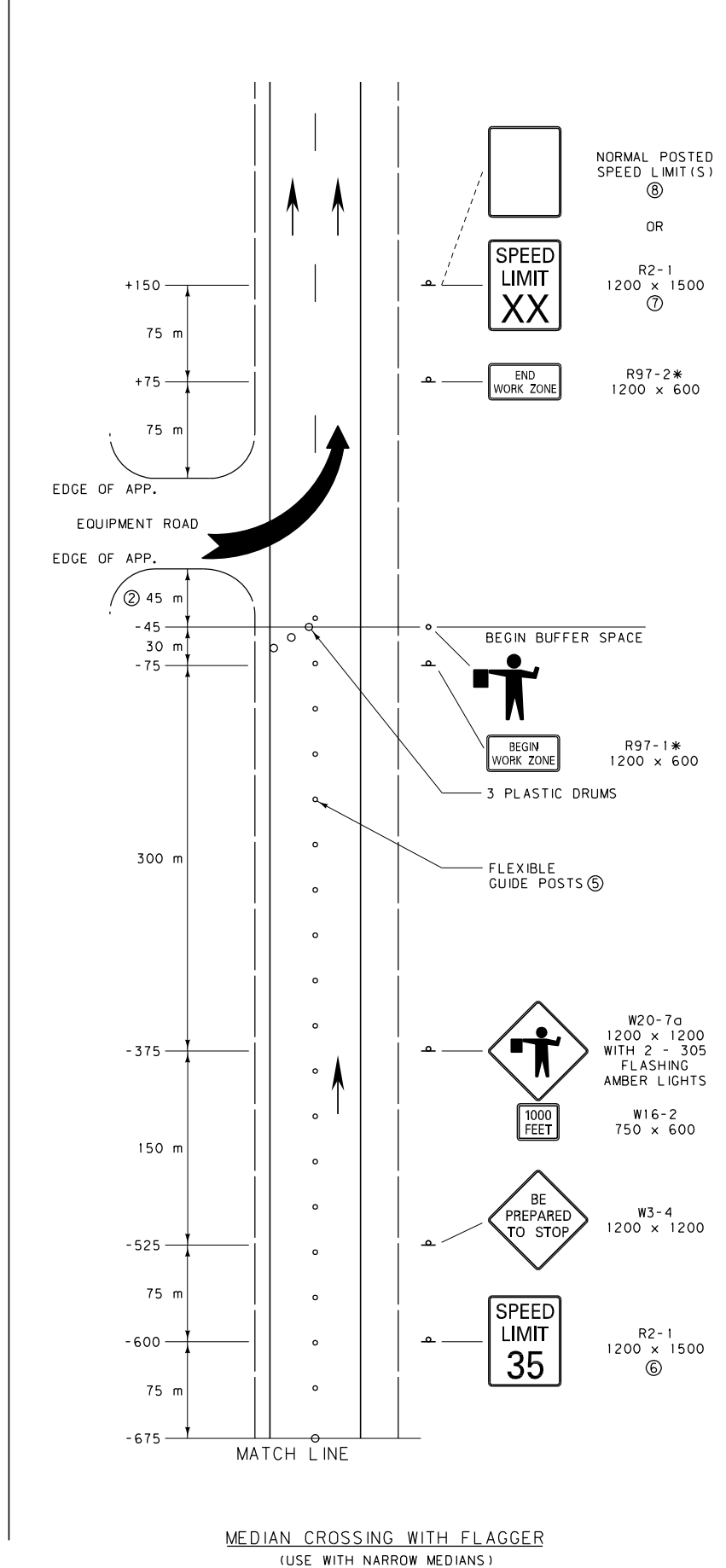
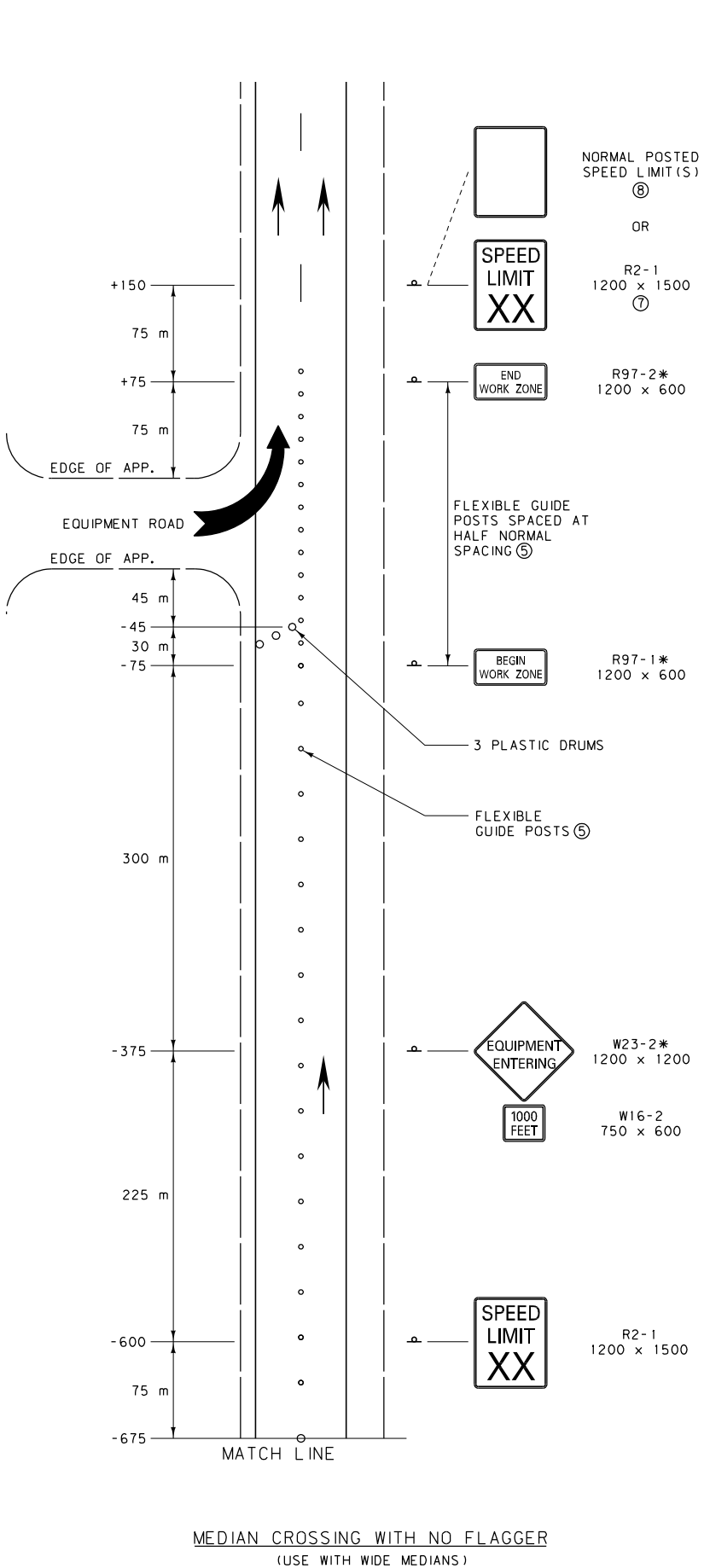
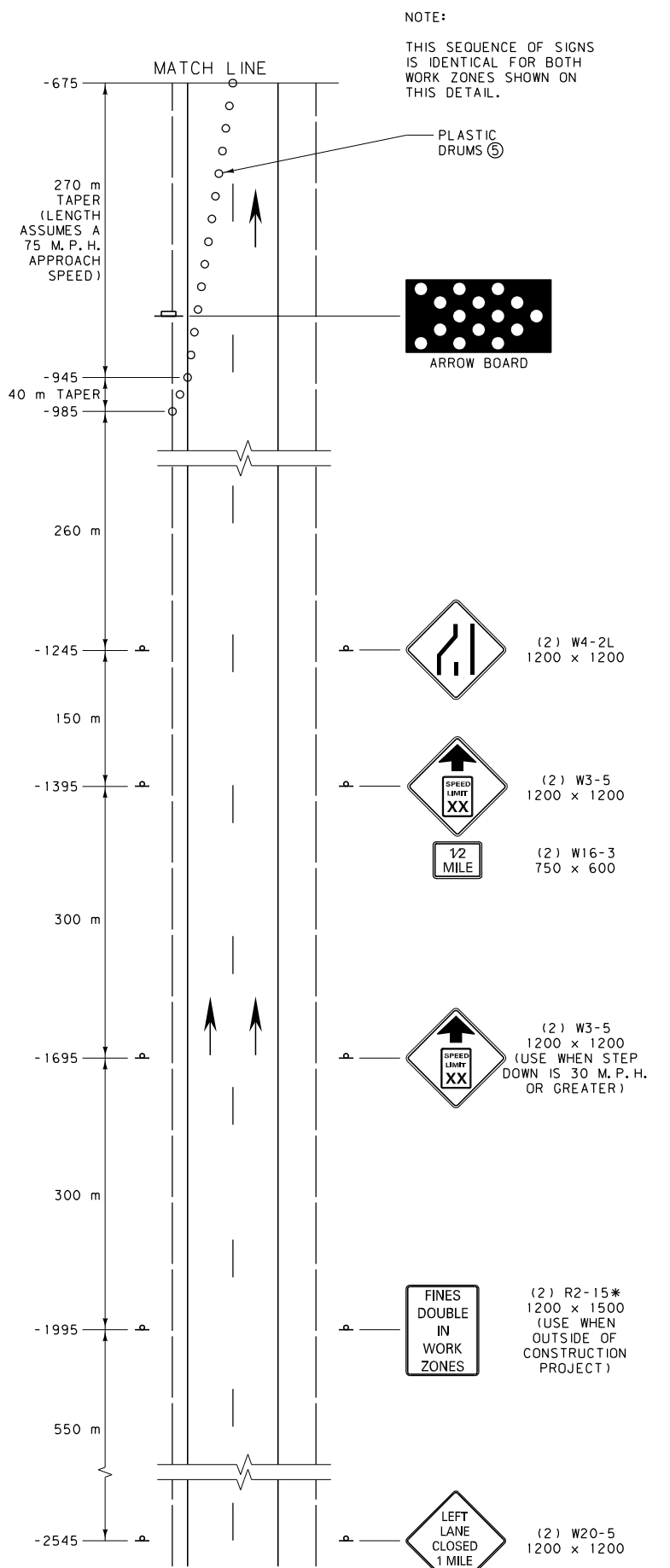

- NOTES:
- ① INCLUDE REGULATORY SIGNING ONLY IF THERE IS REASON TO RESTRICT SPEED WITHIN THE WORK ZONE. MODIFY REGULATORY SIGNS TO MATCH ADJACENT REGULATIONS.
 - ② THE BUFFER SPACE MAY BE INCREASED FOR DOWNGRADES AND OTHER CONDITIONS THAT AFFECT STOPPING DISTANCE.
 - ③ XX = SPEED DETERMINED BY THE ENGINEER.
 - ④ THE WORK ZONE REFERS TO THE AREA WHERE WORK IS ACTUALLY TAKING PLACE. WHEN THIS OCCURS OUTSIDE OF A CONSTRUCTION PROJECT, INCLUDE THE W20-1 AND R2-15* SIGNS.
 - ⑤ SPACE FLEXIBLE GUIDE POSTS ON TANGENTS AT INTERVALS IN METERS OF NO MORE THAN 0.6 TIMES THE SPEED LIMIT IN M.P.H. SPACE PLASTIC DRUMS IN ALL TAPER SECTIONS AT INTERVALS IN METERS OF NO MORE THAN 0.3 TIMES THE SPEED LIMIT IN M.P.H. FOR SPEED LIMITS LESS THAN 35 M.P.H., SPACE CHANNELIZING DEVICES AS DIRECTED BY THE ENGINEER.
 - ⑥ IF FLAGGER IS MORE THAN 1.6 km FROM THE LANE CLOSURE, INCLUDE W3-5 SIGNS, AS REQUIRED.
 - ⑦ POST THE END OF WORK ZONE SPEED LIMIT APPROPRIATE FOR ALL VEHICLES FOR THE REMAINDER OF THE CONSTRUCTION PROJECT BEFORE RESUMING TO NORMAL POSTED SPEED LIMITS AT THE END OF THE CONSTRUCTION PROJECT.
 - ⑧ WHEN OUTSIDE OF A CONSTRUCTION PROJECT, POST THE SPEED LIMIT CONSISTING OF ONE LIMIT WHEN THE NORMAL POSTED SPEED LIMIT FOR ALL VEHICLES IS THE SAME. WHEN CAR AND TRUCK SPEED LIMITS DIFFER, POST BOTH LIMITS ON A SINGLE SIGN.
- * DENOTES SIGNS THAT ARE UNIQUE TO MONTANA.

ALL DIMENSIONS ARE MILLIMETERS (mm) UNLESS OTHERWISE NOTED.

DETAILED DRAWING	
REFERENCE STANDARD SPEC. SECTION 618	DWG. NO. 618-28
DIVIDED FOUR-LANE MEDIAN CROSSINGS	
EFFECTIVE: APRIL 2006	
	MONTANA DEPARTMENT OF TRANSPORTATION

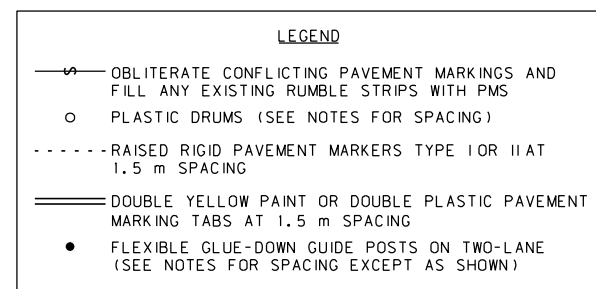
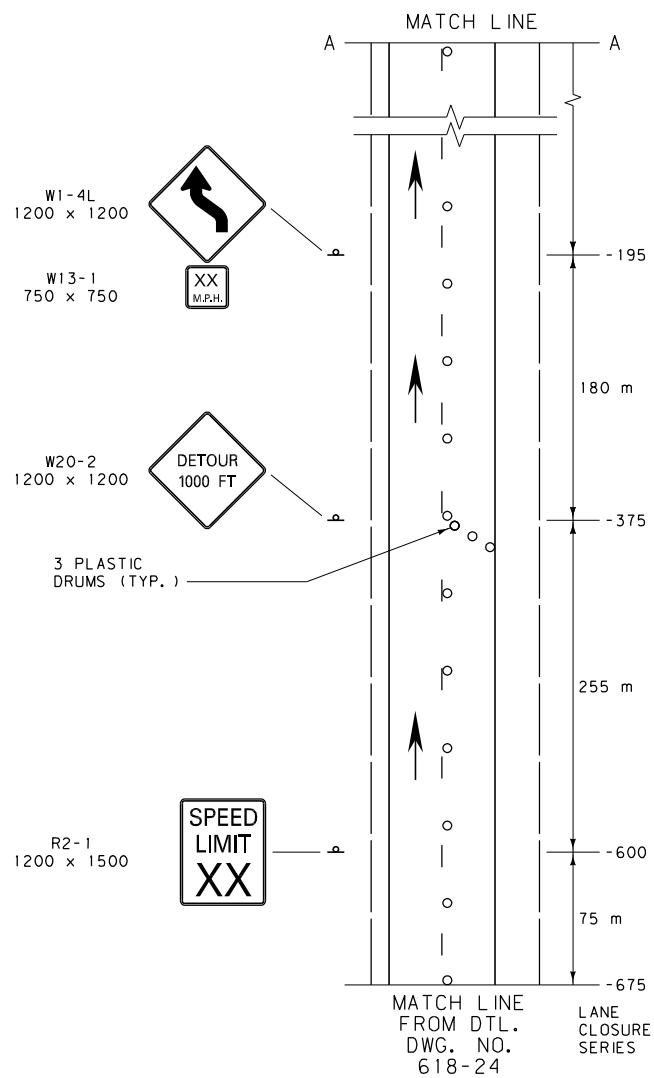

- NOTES:**
- ① INCLUDE REGULATORY SIGNING ONLY AS REQUIRED. MODIFY REGULATORY SIGNS TO MATCH ADJACENT REGULATIONS.
 - ② THE WORK ZONE REFERS TO THE AREA WITHIN THE CONSTRUCTION PROJECT WHERE WORK IS ACTUALLY TAKING PLACE.
 - ③ INDICATED SPACINGS ARE INTENDED TO BE A MAXIMUM AND MAY BE REDUCED IF CONDITIONS WARRANT.
 - ④ XX = SPEED DETERMINED BY THE MEDIAN CROSSING DESIGN SPEED OR THE ENGINEER.
 - ⑤ SPACE CHANNELIZING DEVICES ON TANGENTS AT INTERVALS IN METERS OF NO MORE THAN 0.6 TIMES THE SPEED LIMIT IN M.P.H. AND ON ALL TAPER SECTIONS AT INTERVALS IN METERS OF NO MORE THAN 0.3 TIMES THE SPEED LIMIT IN M.P.H. FOR SPEED LIMITS LESS THAN 35 M.P.H., SPACE CHANNELIZING DEVICES AS DIRECTED BY THE ENGINEER.
 - ⑥ OBLITERATE ALL PAVEMENT MARKINGS THAT CONFLICT AT ANY TIME DURING OR AFTER MEDIAN CROSSING USE.
 - ⑦ USE MATERIALS FOR BARRICADE FRAMEWORK AND ASSEMBLY, INCLUDING ANY SIGNS AND MEANS OF ATTACHMENT, THAT MEET THE REQUIREMENTS FOR NCHRP 350 FOR WORK ZONE DEVICES. ALTERNATIVELY, SIGNS ON BARRICADES MAY BE MOUNTED DIRECTLY BEHIND BARRICADES ON SEPARATE SIGN SUPPORTS.

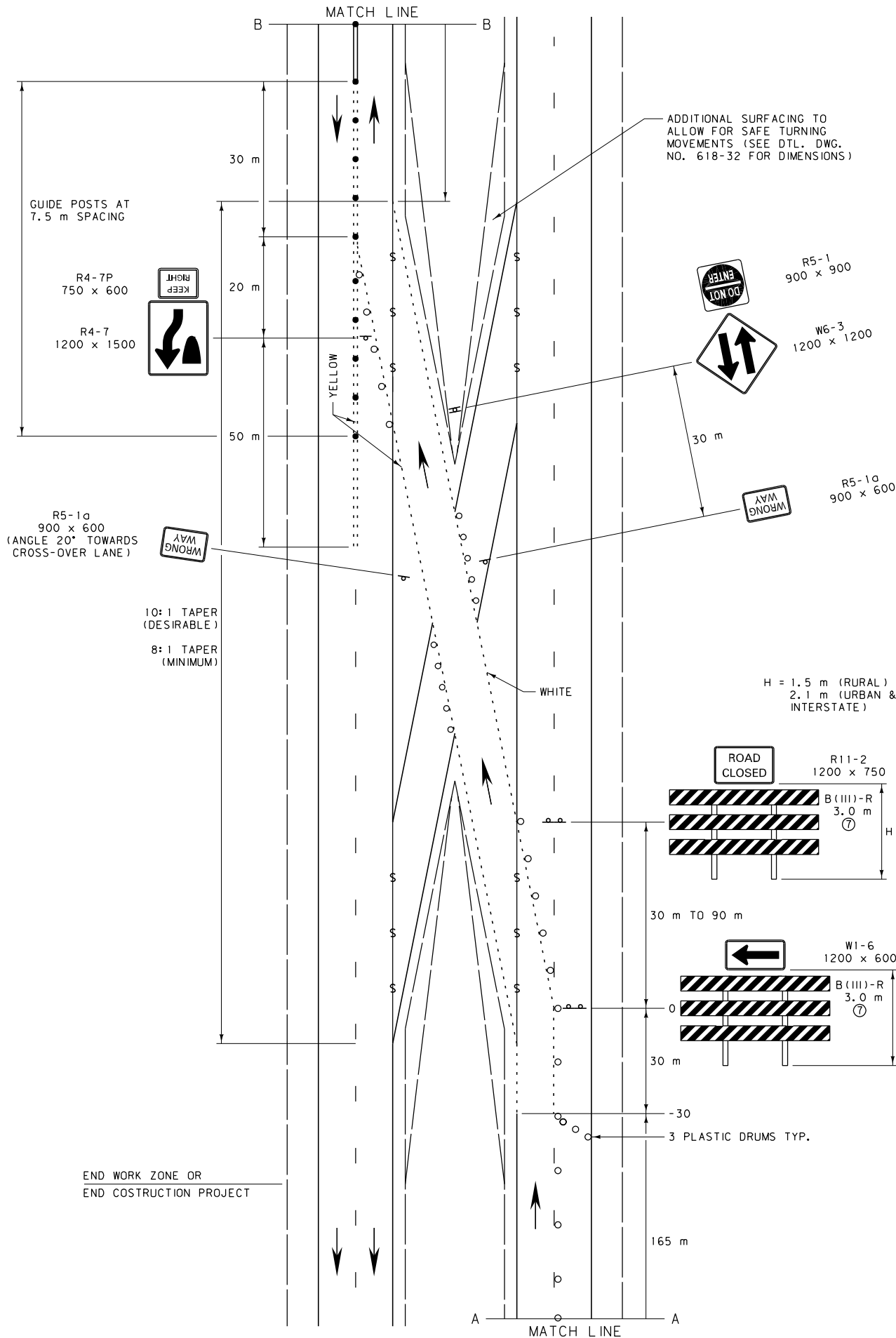

END WORK ZONE OR
END COSTRUCTION PROJECT

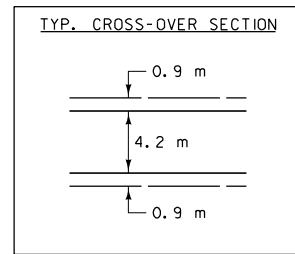
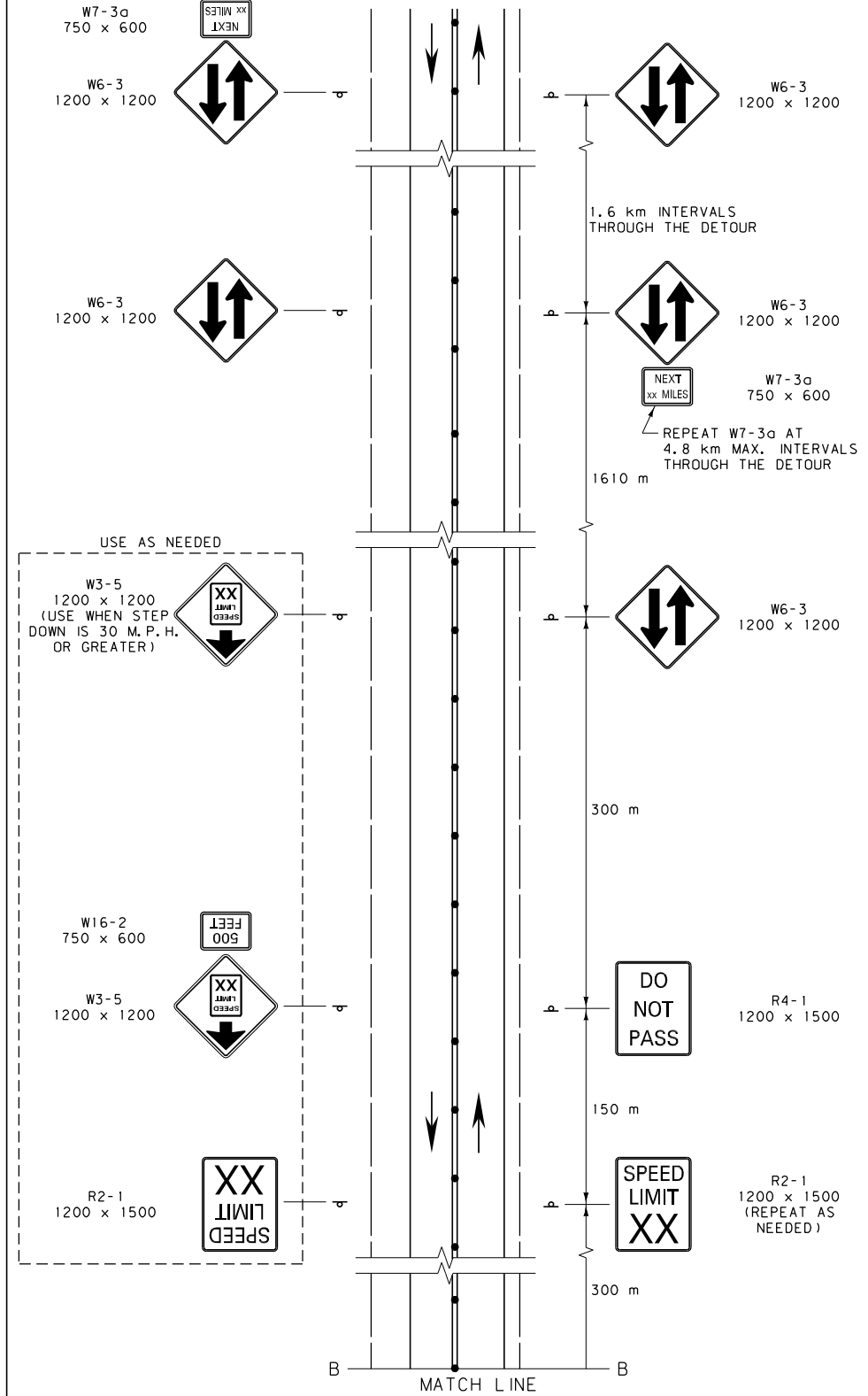

ALL DIMENSIONS ARE MILLIMETERS (mm) UNLESS OTHERWISE NOTED.

DETAILED DRAWING

REFERENCE DWG. NO.
STANDARD SPEC. 618-30

TEMPORARY
FOUR-LANE TO TWO-LANE
MEDIAN CROSSING

EFFECTIVE: APRIL 2006

MDT MONTANA DEPARTMENT OF TRANSPORTATION
serving you with pride

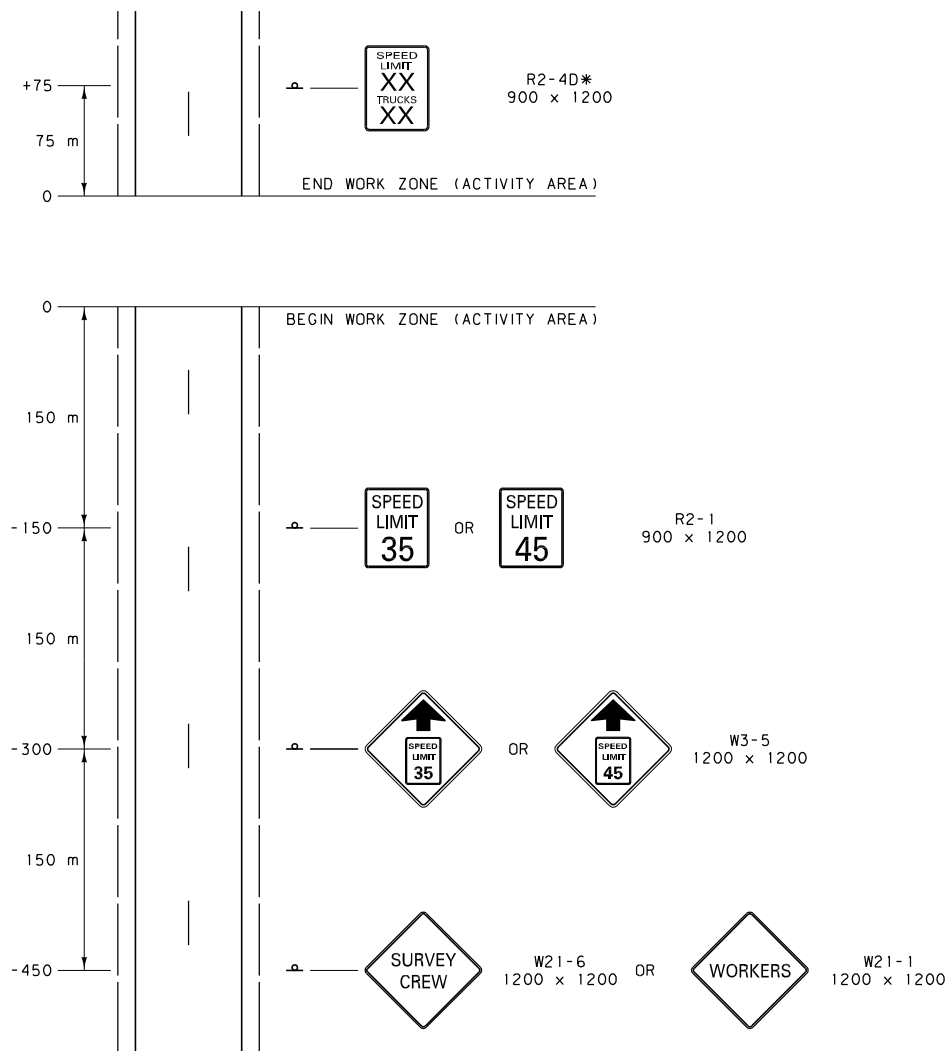

NOTES:

- ① SHORT DURATION ACTIVITIES ARE DEFINED AS THOSE LASTING UP TO ONE HOUR.
 - ② USE THIS SIGN LAYOUT WHEN WORK IS TO TAKE PLACE ON THE TRAVELED WAY. SIGNING FOR WORK ON OR NEAR THE SHOULDER MAY BE LIMITED TO THE USE OF ONE 1200 mm WARNING SIGN FOR EACH TRAVEL DIRECTION. SIGNING FOR WORK OUTSIDE THE SHOULDER MAY BE LIMITED TO THE USE OF ONE 1200 mm WARNING SIGN FOR THE TRAVEL DIRECTION ADJACENT TO THE WORK.
 - ③ SIGN BOTH TRAVEL DIRECTIONS ON TWO-LANE, TWO-WAY ROADWAYS OR BOTH SHOULDERS ON TWO-LANE, ONE-WAY ROADWAYS.
 - ④ PROVIDE AT LEAST THE DISTANCE SHOWN FOR DELINEATOR MOUNTED SIGNS.
 - ⑤ SEE DTL. DWG. NO. 618-36 "SHORT-TERM STATIONARY CREW SIGNING" IF THE DOUBLE PENALTY REGULATION IS TO BE UTILIZED.
 - ⑥ XX = NORMAL POSTED SPEED LIMIT(S).
- * DENOTES SIGNS THAT ARE UNIQUE TO MONTANA.

ALL DIMENSIONS ARE MILLIMETERS (mm) UNLESS OTHERWISE NOTED.

DETAILED DRAWING	
REFERENCE STANDARD SPEC. SECTION 618	DWG. NO. 618-34
SHORT DURATION CREW SIGNING	
EFFECTIVE: APRIL 2006	
 MONTANA DEPARTMENT OF TRANSPORTATION <i>servicing you with pride</i>	

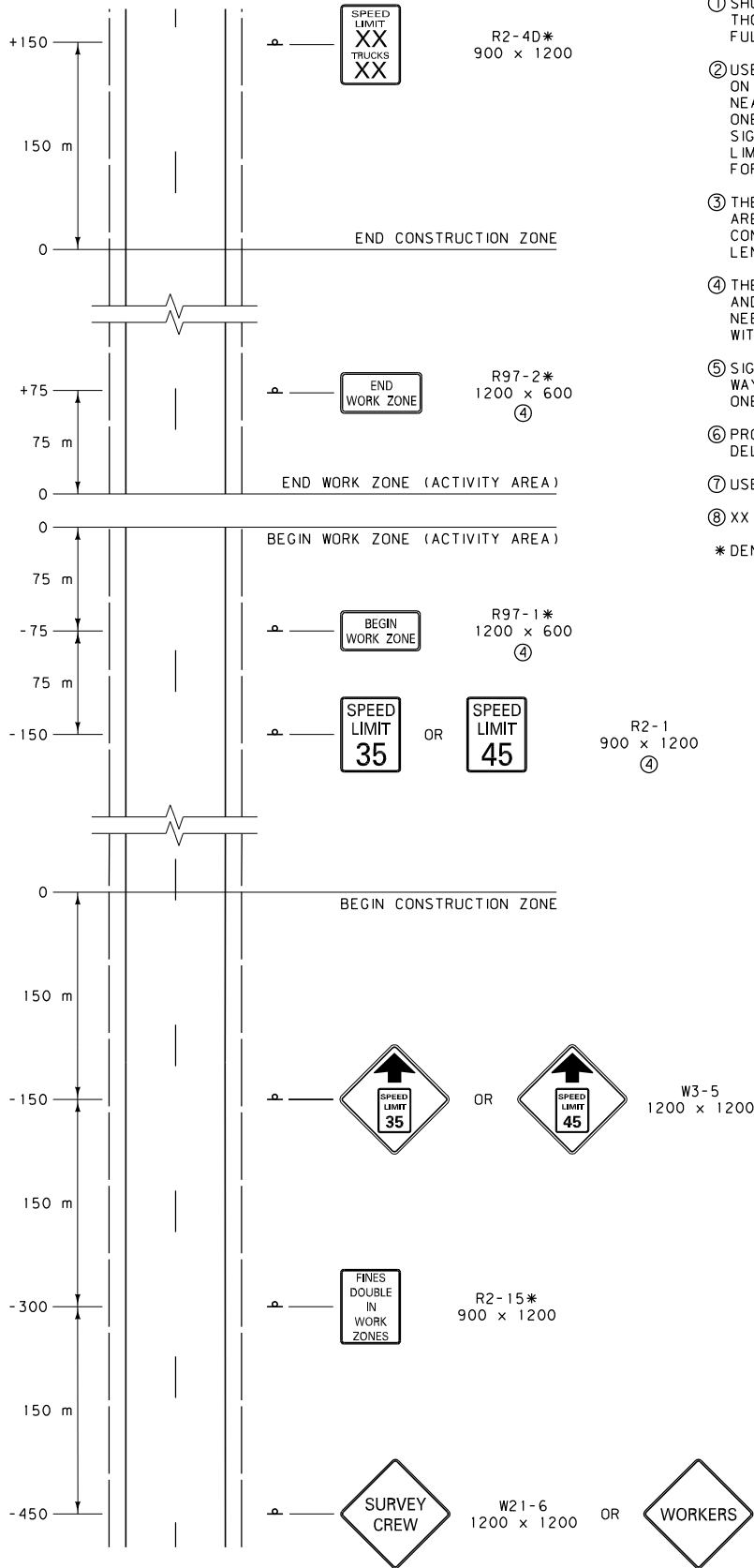

NOTES:

- ① SHORT-TERM STATIONARY ACTIVITIES ARE DEFINED AS THOSE LASTING GREATER THAN ONE HOUR, UP TO A FULL SHIFT.
 - ② USE THIS SIGN LAYOUT WHEN WORK IS TO TAKE PLACE ON THE TRAVELED WAY. SIGNING FOR WORK ON OR NEAR THE SHOULDER MAY BE LIMITED TO THE USE OF ONE 1200 mm WARNING SIGN FOR EACH TRAVEL DIRECTION. SIGNING FOR WORK OUTSIDE THE SHOULDER MAY BE LIMITED TO THE USE OF ONE 1200 mm WARNING SIGN FOR THE TRAVEL DIRECTION ADJACENT TO THE WORK.
 - ③ THE CONSTRUCTION ZONE REFERS TO THE GENERAL AREA THAT REQUIRES TEMPORARY WORK ZONE TRAFFIC CONTROL. IT SHOULD NOT EXCEED 4.8 KILOMETERS IN LENGTH.
 - ④ THE TWO SIGNS MARKING THE WORK ZONE BOUNDARIES AND THE REGULATORY SPEED SIGN MUST MOVE AS NEEDED WITHIN THE CONSTRUCTION ZONE TO REMAIN WITHIN 150 METERS OF THE WORK ACTIVITY.
 - ⑤ SIGN BOTH TRAVEL DIRECTIONS ON TWO-LANE, TWO-WAY ROADWAYS OR BOTH SHOULDERS ON TWO-LANE, ONE-WAY ROADWAYS.
 - ⑥ PROVIDE AT LEAST THE DISTANCE SHOWN FOR DELINEATOR MOUNTED SIGNS.
 - ⑦ USE REFLECTIVE DEVICES.
 - ⑧ XX = NORMAL POSTED SPEED LIMIT(S).
- * DENOTES SIGNS THAT ARE UNIQUE TO MONTANA.

ALL DIMENSIONS ARE MILLIMETERS (mm) UNLESS OTHERWISE NOTED.

DETAILED DRAWING	
REFERENCE STANDARD SPEC. SECTION 618	DWG. NO. 618-36
SHORT-TERM STATIONARY CREW SIGNING	

EFFECTIVE: APRIL 2006

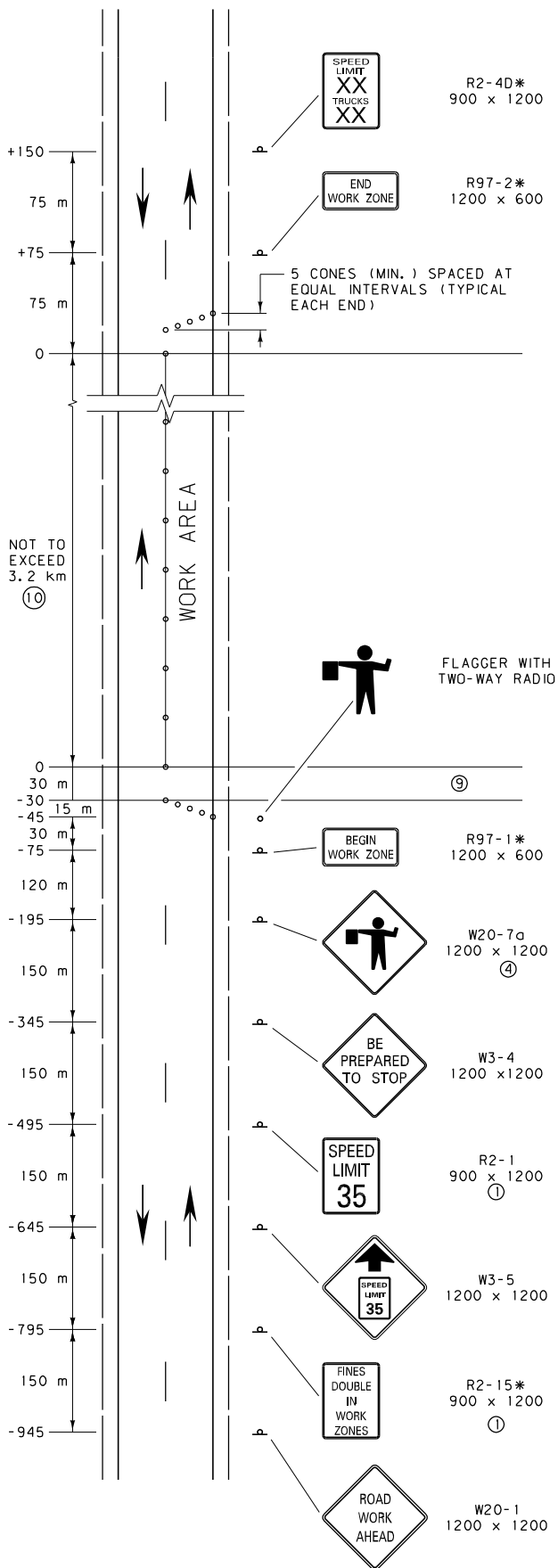

NOTES:

- ① MINIMUM REGULATORY SIGN SIZE IS 600 mm x 750 mm ON TWO-LANE ROADS.
 - ② ON ROADWAYS WITH HIGH TRAFFIC VOLUMES OR VISIBILITY RESTRICTIONS, A 150 m SPACING FOR ALL SIGNS IS RECOMMENDED.
 - ③ SPACE CHANNELIZING DEVICES AT INTERVALS IN METERS OF 0.6 TIMES THE SPEED LIMIT IN M.P.H. THROUGH THE BUFFER AND WORK AREA.
 - ④ IF A NEED ARISES TO INCREASE VEHICLE STORAGE, ADD AN ADDITIONAL W20-7a "FLAGGER AHEAD" SIGN BETWEEN THE R2-1 AND W3-4 SIGNS AND/OR CONSIDER AN ADDITIONAL ADVANCE FLAGGER.
 - ⑤ A MIRROR IMAGE OF THIS SIGN SEQUENCE IS REQUIRED FOR THE TRAFFIC FROM THE OPPOSITE DIRECTION.
 - ⑥ FOR MORE INFORMATION OR CLARIFICATION CONTACT THE DISTRICT TRAFFIC ENGINEER. FOR EXAMPLE, IF WORK ZONE IS CLOSE TO A HORIZONTAL CURVE, A VERTICAL CURVE, A BRIDGE, INTERCHANGE, POOR SIGHT DISTANCE, OR OTHER SPECIAL CONDITION.
 - ⑦ COVER ANY CONFLICTING SIGNS IN THE WORK ZONE.
 - ⑧ SHORT-TERM WORK ZONE SIGNING IS NOT REQUIRED TO BE POST MOUNTED.
 - ⑨ THE BUFFER SPACE CAN BE LATERAL AND LONGITUDINAL AND MAY BE INCREASED FOR DOWNGRADES AND OTHER CONDITIONS THAT AFFECT STOPPING DISTANCE.
 - ⑩ TYPICALLY 3.2 KILOMETERS IS THE MAX. WORK AREA. HOWEVER, WHEN SIGHT DISTANCE, BUFFER ZONES OR ACCOMPLISHMENT RATES FOR EQUIPMENT ARE CONSIDERED, SOME MINOR ADJUSTMENTS TO THIS MAX. MAY BE CONSIDERED.
 - ⑪ XX = NORMAL POSTED SPEED LIMIT(S).
- * DENOTES SIGNS THAT ARE UNIQUE TO MONTANA.

ALL DIMENSIONS ARE MILLIMETERS (mm) UNLESS OTHERWISE NOTED.

DETAILED DRAWING	
REFERENCE STANDARD SPEC. SECTION 618	DWG. NO. 618-M1
MAINTENANCE GUIDELINE FOR SHORT-TERM TWO-LANE CRACK SEALING WORK ZONE	

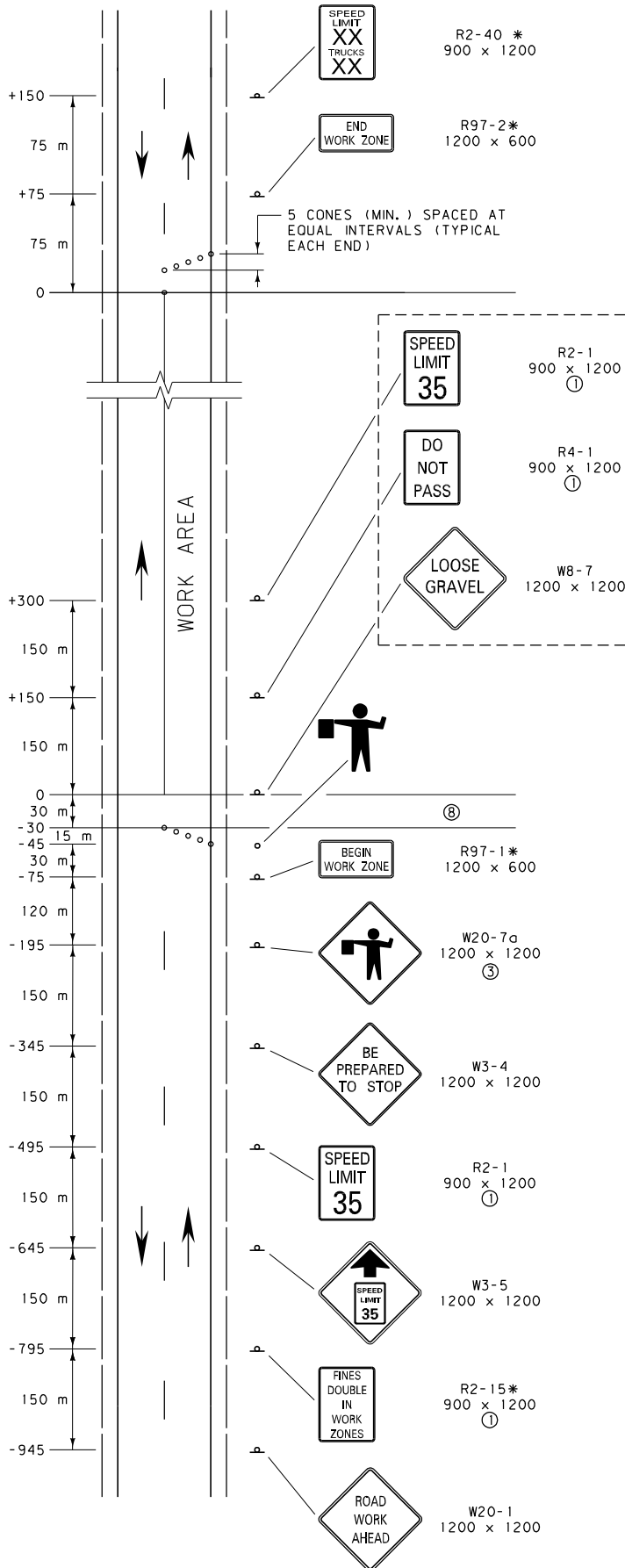

NOTE:
TO BE POSTED AT THE START OF THE WORK AND REPEATED AT 3.2 km INTERVALS UNTIL THE SURFACE IS SWEEPED AND STRIPED.

NOTES:

- ① MINIMUM REGULATORY SIGN SIZE IS 600 mm x 750 mm ON TWO-LANE ROADS.
 - ② ON ROADWAYS WITH HIGH TRAFFIC VOLUMES OR VISIBILITY RESTRICTIONS, A 150 m SPACING FOR ALL SIGNS IS RECOMMENDED.
 - ③ IF A NEED ARISES TO INCREASE VEHICLE STORAGE, ADD AN ADDITIONAL W20-7a "FLAGGER AHEAD" SIGN BETWEEN THE R2-1 AND W3-4 SIGNS AND/OR CONSIDER AN ADDITIONAL ADVANCE FLAGGER.
 - ④ A MIRROR IMAGE OF THIS SIGN SEQUENCE IS REQUIRED FOR THE TRAFFIC FROM THE OPPOSITE DIRECTION.
 - ⑤ FOR MORE INFORMATION OR CLARIFICATION CONTACT THE DISTRICT TRAFFIC ENGINEER. FOR EXAMPLE, IF WORK ZONE IS CLOSE TO A HORIZONTAL CURVE, A VERTICAL CURVE, A BRIDGE, INTERCHANGE, POOR SIGHT DISTANCE OR OTHER SPECIAL CONDITION.
 - ⑥ COVER ANY CONFLICTING SIGNS IN THE WORK ZONE.
 - ⑦ SHORT-TERM WORK ZONE SIGNING IS NOT REQUIRED TO BE POST MOUNTED.
 - ⑧ THE BUFFER SPACE CAN BE LATERAL AND LONGITUDINAL AND MAY BE INCREASED FOR DOWNGRADES AND OTHER CONDITIONS THAT AFFECT STOPPING DISTANCE.
 - ⑨ XX = NORMAL POSTED SPEED LIMIT(S).
- * DENOTES SIGNS THAT ARE UNIQUE TO MONTANA.

ALL DIMENSIONS ARE MILLIMETERS (mm) UNLESS OTHERWISE NOTED.

DETAILED DRAWING	
REFERENCE STANDARD SPEC. SECTION 618	DWG. NO. 618-M2
MAINT. GUIDELINE FOR SHORT-TERM TWO-LANE CHIP SEAL & OVERLAY (PILOTED TRAFFIC)	
EFFECTIVE: APRIL 2006	

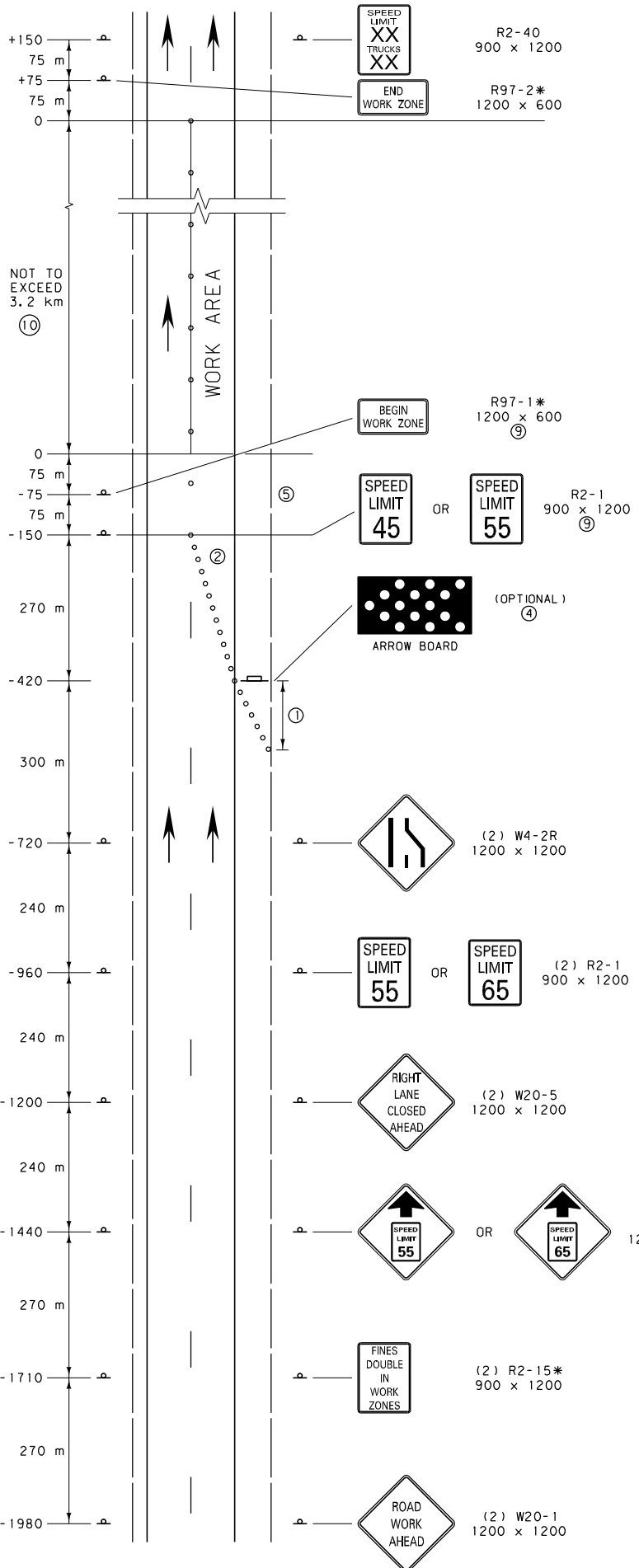

NOTES:

- ① USE A MINIMUM 90 m SHOULDER TAPER.
 - ② USE THIRTEEN APPROVED CHANNELIZING DEVICES FOR A 3.6 m LANE CLOSURE TAPER (75 M.P.H. SPACED AT 22.5 m.) ASSURE THAT THE TAPER IS A MINIMUM LENGTH OF 270 m.
 - ③ SPACE CHANNELIZING DEVICES AT INTERVALS IN METERS OF 0.6 TIMES THE SPEED LIMIT IN M.P.H. THROUGH THE BUFFER AND WORK AREA.
 - ④ PLACE THE ARROW BOARD (IF USED) ON THE SHOULDER AT THE START OF THE TRAVEL LANE CLOSURE TAPER.
 - ⑤ THE BUFFER SPACE CAN BE LATERAL AND LONGITUDINAL. KEEP THE BUFFER SPACE CLEAR OF EQUIPMENT AND PERSONNEL.
 - ⑥ FOR MORE INFORMATION OR CLARIFICATION CONTACT THE DISTRICT TRAFFIC ENGINEER. FOR EXAMPLE, IF WORK AREA IS CLOSE TO A HORIZONTAL CURVE, A VERTICAL CURVE, A BRIDGE, INTERCHANGE, POOR SIGHT DISTANCE OR OTHER SPECIAL CONDITION.
 - ⑦ COVER ANY CONFLICTING SIGNS IN THE WORK AREA.
 - ⑧ SHORT-TERM WORK ZONE SIGNING IS NOT REQUIRED TO BE POST MOUNTED.
 - ⑨ WHEN THE WORK ZONE CHANGES WITHIN THE CONSTRUCTION ZONE THESE SIGNS SHOULD BE MOVED TO REFLECT THE ACTUAL WORK ZONE.
 - ⑩ TYPICALLY 3.2 KILOMETERS IS THE MAX. WORK AREA. HOWEVER, WHEN SIGHT DISTANCE, BUFFER ZONES OR ACCOMPLISHMENT RATES FOR EQUIPMENT ARE CONSIDERED, SOME MINOR ADJUSTMENTS TO THIS MAX. MAY BE CONSIDERED.
 - ⑪ XX = NORMAL POSTED SPEED LIMIT(S).
- * DENOTES SIGNS THAT ARE UNIQUE TO MONTANA.

ALL DIMENSIONS ARE MILLIMETERS (mm) UNLESS OTHERWISE NOTED.

DETAILED DRAWING	
REFERENCE STANDARD SPEC. SECTION 618	DWG. NO. 618-M3
MAINTENANCE GUIDELINE FOR SHORT-TERM LANE CLOSURE ON INTERSTATE	
EFFECTIVE: APRIL 2006	
 MONTANA DEPARTMENT OF TRANSPORTATION <i>servicing you with pride</i>	

POSTED SPEED LIMIT FOR WORK ZONE (M. P. H.)	SIGN SPACING (A)	SPACING OF CHANNELIZING DEVICES (MAX.) (G) **	BUFFER SPACE ④ (B)
25	30	8	15
35	30	12	30

** SPACE ALL CHANNELIZING DEVICES AT "G" UNLESS OTHERWISE NOTED.

SIGN LAYOUT IDENTICAL TO OPPOSING TRAFFIC SIGN LAYOUT

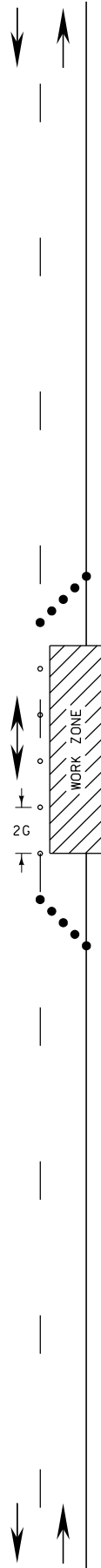
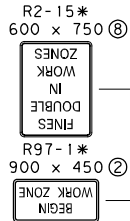

NOTES:

- USE THIS SIGN LAYOUT IN URBAN APPLICATIONS ONLY. USE THE RURAL, OPEN ROADWAY SIGNING DETAILS WHEN HIGHER SPEED LIMITS ARE USED.
- THE WORK ZONE REFERS TO THE AREA WHERE WORK IS ACTUALLY TAKING PLACE. KEEP THE BEGIN AND END WORK ZONE SIGNS WITHIN 150 m OF THE WORK ZONE BOUNDARY. INCLUDE THE BEGIN AND END WORK ZONE SIGNS WHEN WORK IS IN PROGRESS OR WHEN CONDITIONS WARRANT.
- INCLUDE SPEED LIMIT SIGNS ONLY IF THERE IS A REASON TO RESTRICT SPEED. COVER CONFLICTING EXISTING SPEED LIMIT SIGNS.
- THE BUFFER SPACE MAY BE INCREASED FOR DOWNGRADES AND OTHER CONDITIONS THAT AFFECT STOPPING DISTANCE.
- IF PEDESTRIAN TRAFFIC IS IMPACTED SEE DTL. DWG. NO. 618-U05.
- LARGER SIGN SIZES MAY BE APPROVED BY THE ENGINEER.
- PLACE END ROADWORK SIGN AT END OF PROJECT LIMITS.
- IN LIEU OF TWO SIGNS, THE FINES DOUBLE AND BEGIN WORK ZONE SIGNS CAN BE COMBINED ON ONE SIGN FACE.
- POST EXISTING SPEED LIMIT IF CHANGED BY WORKZONE.

LEGEND

- - FLEXIBLE GUIDE POSTS
- - PLASTIC DRUMS
- * - DENOTES SIGNS THAT ARE UNIQUE TO MONTANA.
- XX - SPEED DETERMINED BY THE ENGINEER. (25 M. P. H. OR 35 M. P. H.)

DETAILED DRAWING	
REFERENCE STANDARD SPEC. SECTION 618	DWG. NO. 618-U01

LANE CLOSURE-FLAGGER CONTROLLED (URBAN TWO LANE, TWO WAY ROAD)

EFFECTIVE: MAY 2009



ALL DIMENSIONS ARE MILLIMETERS (mm) UNLESS OTHERWISE NOTED.

POSTED SPEED LIMIT FOR WORK ZONE	SIGN SPACING (A)	TAPER LENGTH (L)	SPACING OF CHANNELIZING DEVICES (MAX.) (G) **	BUFFER SPACE ④ (B)
(M. P. H.)	m	m	m	m
25	30	40	8	15
35	30	84	12	30

** SPACE ALL CHANNELIZING DEVICES AT "G" UNLESS OTHERWISE NOTED.

NOTES:

- ① USE THIS SIGN LAYOUT IN URBAN APPLICATIONS ONLY. USE THE RURAL, OPEN ROADWAY SIGNING DETAILS WHEN HIGHER SPEED LIMITS ARE USED.
- ② THE WORK ZONE REFERS TO THE AREA WHERE WORK IS ACTUALLY TAKING PLACE. KEEP THE BEGIN AND END WORK ZONE SIGNS WITHIN 150 m OF THE WORK ZONE BOUNDARY. INCLUDE THE BEGIN AND END WORK ZONE SIGNS WHEN WORK IS IN PROGRESS OR WHEN CONDITIONS WARRANT.
- ③ INCLUDE SPEED LIMIT SIGNS ONLY IF THERE IS A REASON TO RESTRICT SPEED. COVER CONFLICTING EXISTING SPEED LIMIT SIGNS.
- ④ THE BUFFER SPACE MAY BE INCREASED FOR DOWNGRADES AND OTHER CONDITIONS THAT AFFECT STOPPING DISTANCE.
- ⑤ THIS LAYOUT SHOULD ONLY BE USED WHEN THERE IS AT LEAST 3.0 m IN WIDTH BETWEEN THE CHANNELIZING DEVICES AND THE EDGE OF PAVEMENT.
- ⑥ IF PEDESTRIAN TRAFFIC IS IMPACTED SEE DTL. DWG. NO. 618-U05.
- ⑦ LARGER SIGN SIZES MAY BE APPROVED BY THE ENGINEER.
- ⑧ PLACE END ROAD WORK SIGNS AT END OF PROJECT LIMITS.
- ⑨ POST EXISTING SPEED LIMIT IF CHANGED BY WORK ZONE.
- ⑩ IN LIEU OF TWO SIGNS, THE FINES DOUBLE AND BEGIN WORK ZONE SIGNS CAN BE COMBINED ON ONE SIGN FACE.

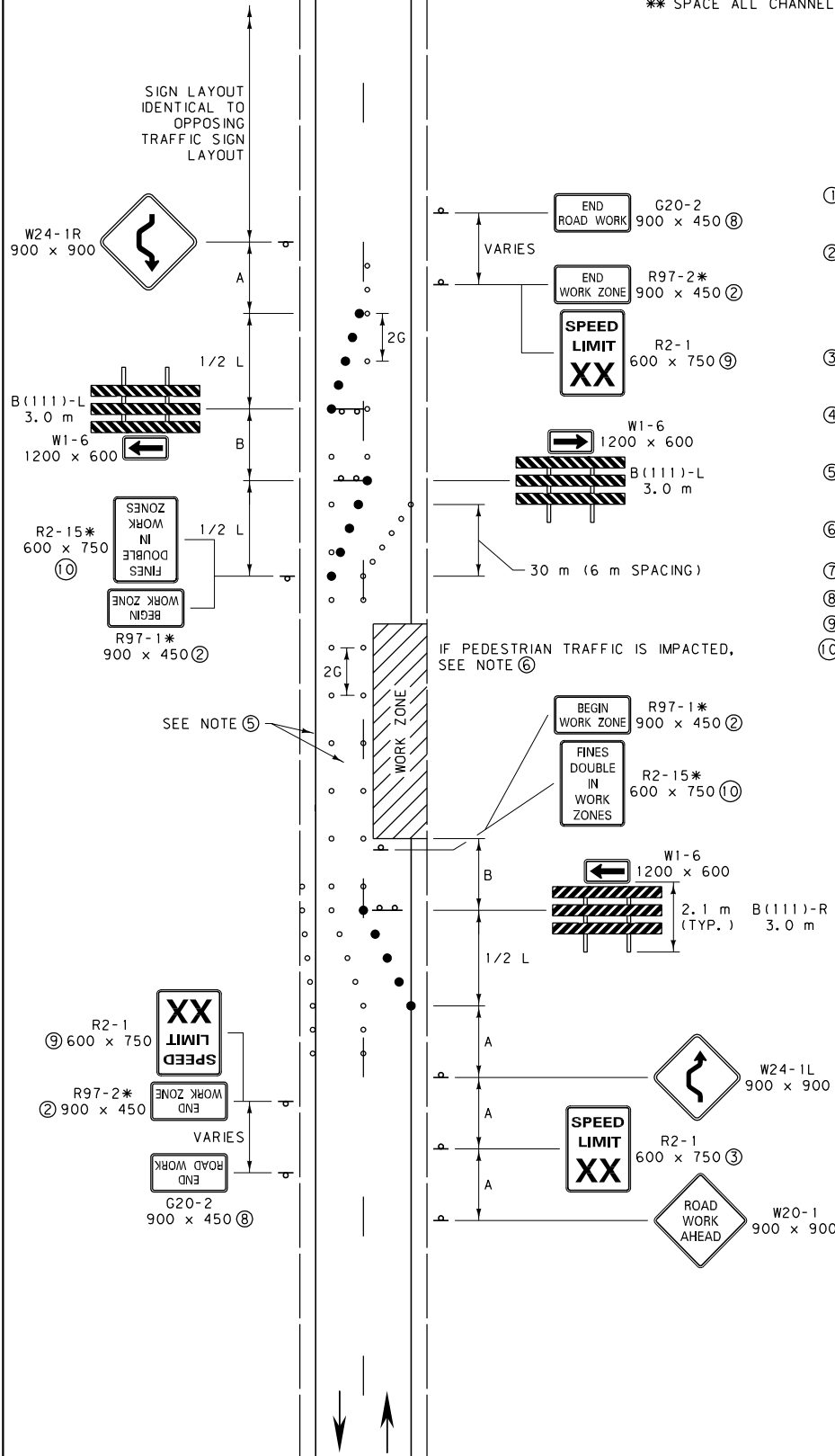

LEGEND

- - FLEXIBLE GUIDE POSTS
- - PLASTIC DRUMS
- * - DENOTES SIGNS THAT ARE UNIQUE TO MONTANA.
- XX - SPEED DETERMINED BY THE ENGINEER. (25 M. P. H. OR 35 M. P. H.)

ALL DIMENSIONS ARE MILLIMETERS (mm) UNLESS OTHERWISE NOTED.

DETAILED DRAWING	
REFERENCE STANDARD SPEC. SECTION 618	DWG. NO. 618-U02
WORK ZONE OCCUPIES ONE HALF OF ROAD (LOW SPEED URBAN TWO-LANE, TWO-WAY ROAD)	
EFFECTIVE: MAY 2009	

POSTED SPEED LIMIT FOR WORK ZONE (M. P. H.)	SIGN SPACING (A)	TAPER LENGTH (L)	SPACING OF CHANNELIZING DEVICES (MAX.) (G) **	BUFFER SPACE (B)
25	30	40	8	15
35	30	84	12	30

** SPACE ALL CHANNELIZING DEVICES AT "G" UNLESS OTHERWISE NOTED.

NOTES:

- ① USE THIS SIGN LAYOUT IN URBAN APPLICATIONS ONLY. USE THE RURAL, OPEN ROADWAY SIGNING DETAILS WHEN HIGHER SPEED LIMITS ARE USED.
- ② THE WORK ZONE REFERS TO THE AREA WHERE WORK IS ACTUALLY TAKING PLACE. KEEP THE BEGIN AND END WORK ZONE SIGNS WITHIN 150 m OF THE WORK ZONE BOUNDARY. INCLUDE THE BEGIN AND END WORK ZONE SIGNS WHEN WORK IS IN PROGRESS OR WHEN CONDITIONS WARRANT.
- ③ INCLUDE SPEED LIMIT SIGNS ONLY IF THERE IS A REASON TO RESTRICT SPEED. COVER CONFLICTING EXISTING SPEED LIMIT SIGNS.
- ④ THE BUFFER SPACE MAY BE INCREASED FOR DOWNGRADES AND OTHER CONDITIONS THAT AFFECT STOPPING DISTANCE.
- ⑤ THIS LAYOUT SHOULD ONLY BE USED WHEN THERE IS AT LEAST 3 m IN WIDTH BETWEEN THE CHANNELIZING DEVICES AND THE EDGE OF PAVEMENT. PROVIDE NO PARKING SIGNS WHEN APPROPRIATE.
- ⑥ LARGER SIGNS MAY BE APPROVED BY THE ENGINEER.
- ⑦ PLACE END ROAD WORK SIGNS AT END OF PROJECT LIMITS.
- ⑧ IN LIEU OF TWO SIGNS, THE FINES DOUBLE AND BEGIN WORK ZONE SIGNS CAN BE COMBINED ON ONE SIGN FACE.
- ⑨ POST EXISTING SPEED LIMIT IF CHANGED BY WORK ZONE.

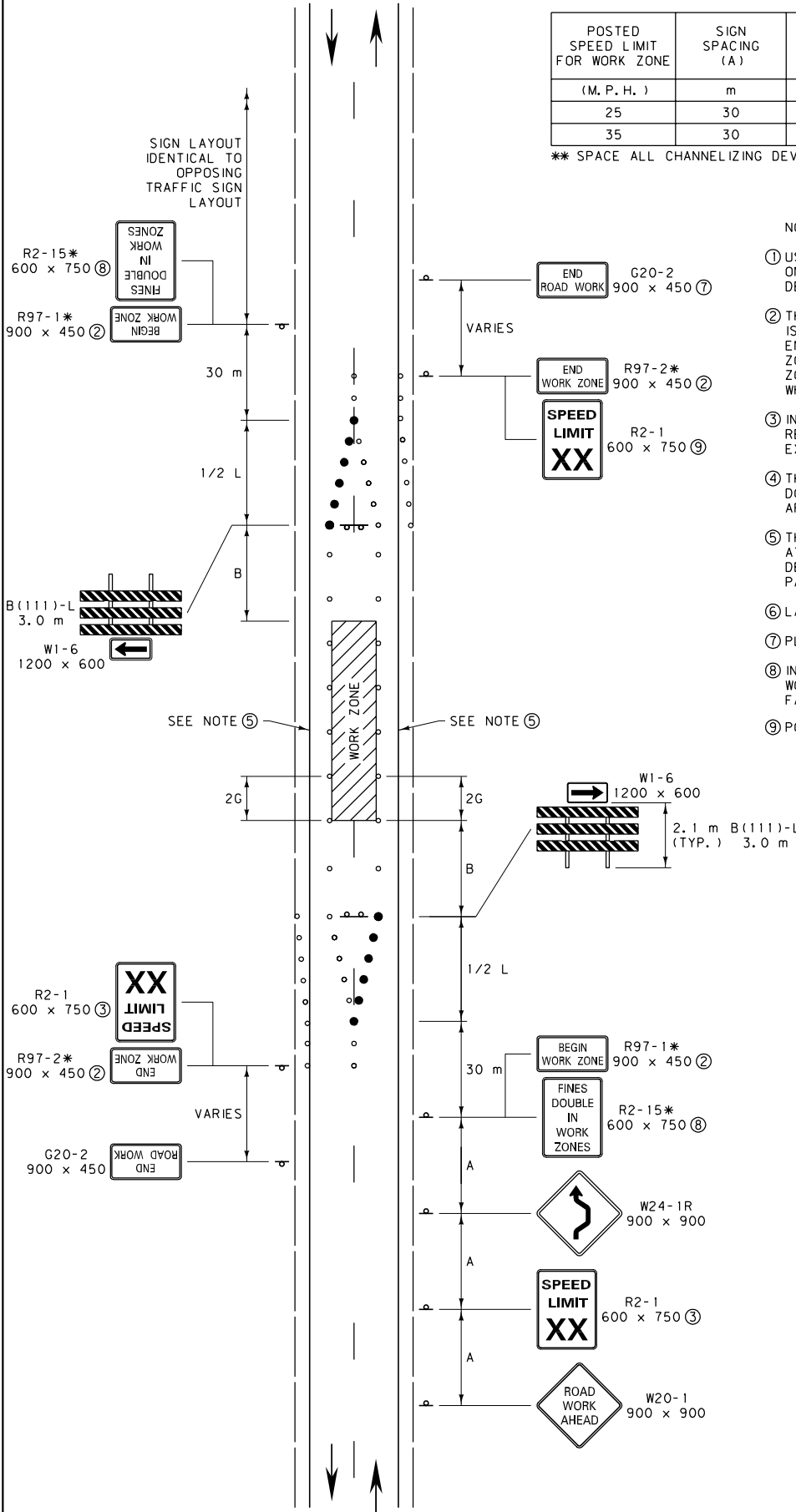

LEGEND

- - FLEXIBLE GUIDE POSTS
- - PLASTIC DRUMS
- * - DENOTES SIGNS THAT ARE UNIQUE TO MONTANA.
- XX - SPEED DETERMINED BY THE ENGINEER. (25 M. P. H. OR 35 M. P. H.)

ALL DIMENSIONS ARE MILLIMETERS (mm) UNLESS OTHERWISE NOTED.

DETAILED DRAWING	
REFERENCE STANDARD SPEC. SECTION 618	DWG. NO. 618-U03
WORK ZONE IN CENTER OF ROAD (URBAN TWO-LANE, TWO-WAY ROAD)	
EFFECTIVE: MAY 2009	
MONTANA DEPARTMENT OF TRANSPORTATION <i>servicing you with pride</i>	

