

REGULATORY
R1-1 / R1-2

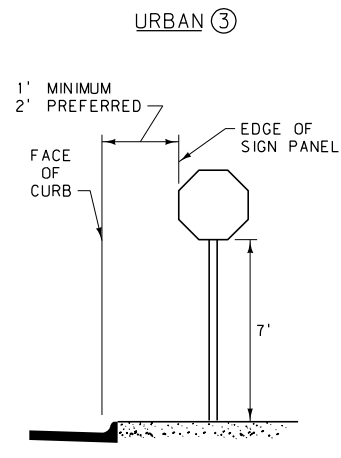

GUIDE SIGNS

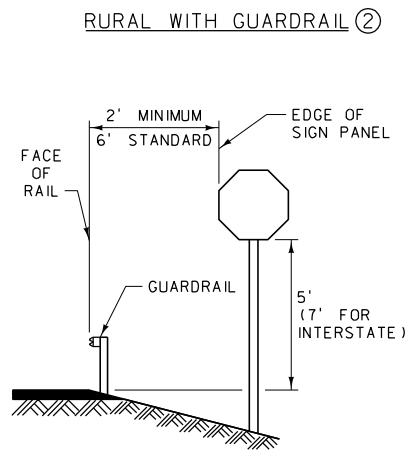
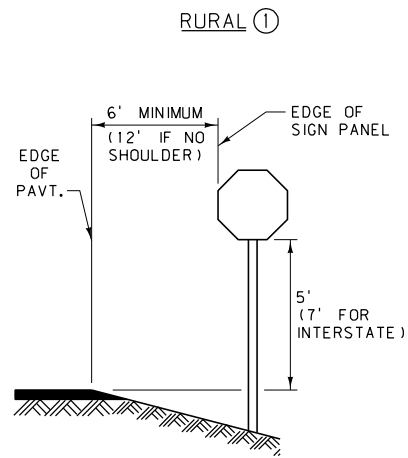
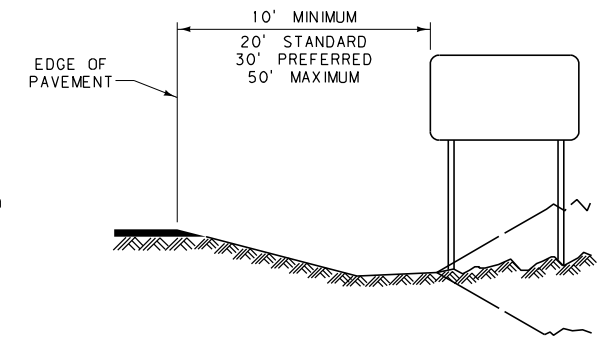
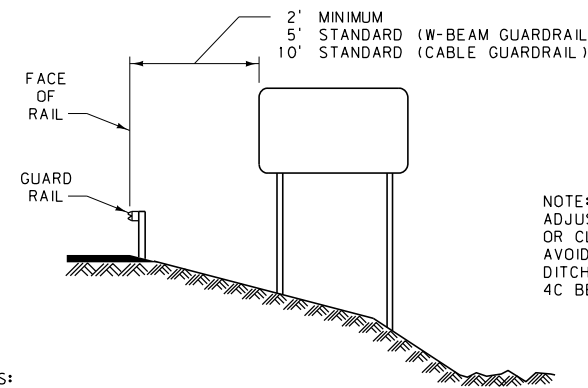

NOTE:
ADJUST SIGN LOCATION
OR CLEARANCE SLIGHTLY TO
AVOID PLACING POSTS IN
DITCH BOTTOMS. SEE NOTE
4C BELOW.

NOTES:

- PLACE ALL SIGNS AT THE CLEARANCE AND MOUNTING HEIGHTS SHOWN.
 - FOR REGULATORY, WARNING AND ROUTE MARKER SIGNS, AND THEIR ASSEMBLIES, ON HIGHWAYS OTHER THAN INTERSTATE:
 - USE DIAGRAMS LOCATED IN COLUMN ① WHEN PLACING THESE SIGNS IN STANDARD RURAL CONDITIONS. USE COLUMN ② WHEN PLACING THESE SIGNS BEHIND GUARDRAIL IN RURAL CONDITIONS. USE COLUMN ③ WHEN PLACING THESE SIGNS IN URBAN CONDITIONS WHERE THERE IS ADEQUATE CLEARANCE AND SIDEWALK WIDTH.
 - WHERE SIDEWALK WIDTH IS LIMITED IN URBAN CONDITIONS, SEE DTL. DWG. NO. 619-18 FOR PLACEMENT DETAILS.
 - FOR REGULATORY (ALL OTHER), WARNING AND ROUTE MARKER SIGNS, AND THEIR ASSEMBLIES, ON INTERSTATE HIGHWAYS: THE CLEARANCE IS 20' FROM THE EDGE OF PAVEMENT IN COLUMN ① FOR STANDARD RURAL CONDITIONS. THE CLEARANCES LISTED IN COLUMNS ② AND ③ REMAIN AS SHOWN.
 - FOR GUIDE SIGNS AND THEIR ASSEMBLIES:
 - USE THE DIAGRAMS LOCATED ABOVE WHEN PLACING THESE SIGNS IN THE GIVEN RURAL CONDITIONS.
- B) FOR PLACEMENT OF THESE SIGNS IN URBAN CONDITIONS, SEE THE SIGN LOCATION AND SPECIFICATION SHEETS IN THE SIGNING PLANS FOR EACH INDIVIDUAL SIGN.
C) THE MAXIMUM CLEARANCE OF THESE SIGNS IS 50' IN ANY CONDITION.
D) SEE DTL. DWG. NO. 619-08 FOR MOUNTING HEIGHTS.
- WITHIN THE CITY LIMITS OR IN A SIDEWALK AND CURB AREA, MOUNT SIGNS TO HAVE THE PROPER CLEARANCES, BUT AVOID ANY CONFLICT BETWEEN THE POST AND THE MAIN WALKING AREA OF THE SIDEWALK, OR WITH DOORWAYS OR WINDOWS OF ADJACENT BUILDINGS. THE EXACT LOCATION OF THESE SIGN INSTALLATIONS WILL BE DETERMINED BY THE ENGINEER. SEE DTL. DWG. NO. 619-18 FOR VARIOUS CANTILEVER TYPE MOUNTINGS.
 - EVALUATE SIGNS WITHIN CLEAR ZONES (TABLES BELOW) FOR SUPPORT BREAKAWAY REQUIREMENTS (CONTACT MDT TRAFFIC SECTION FOR CRITERIA).

REGULATORY
EXCEPT R1-1 / R1-2

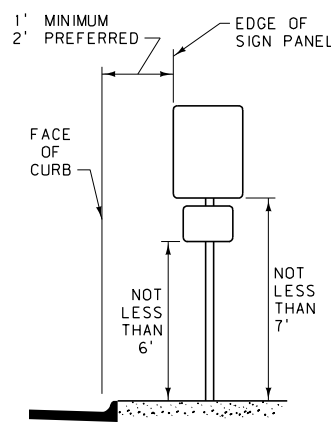
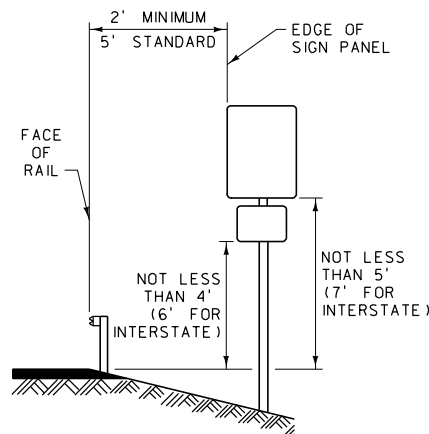
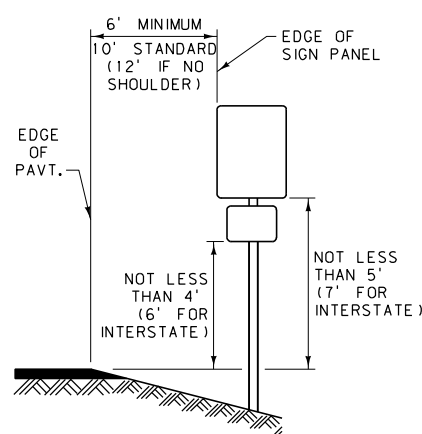

WARNING

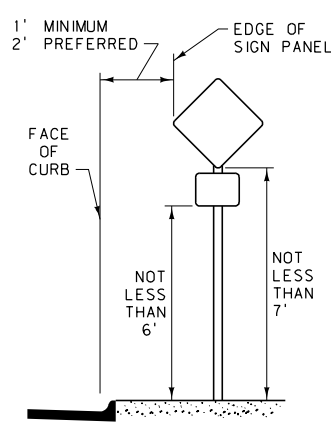
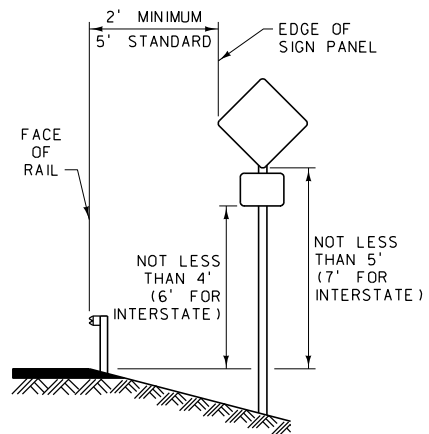
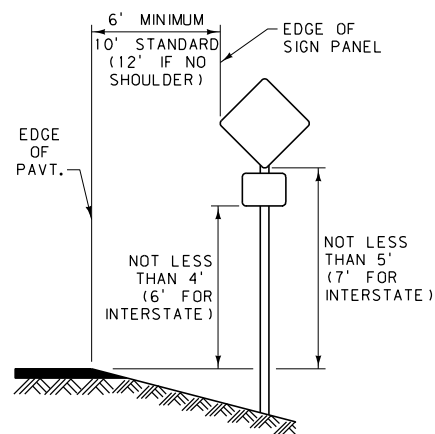

ROUTE MARKERS

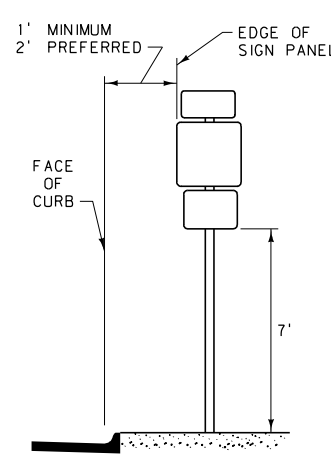
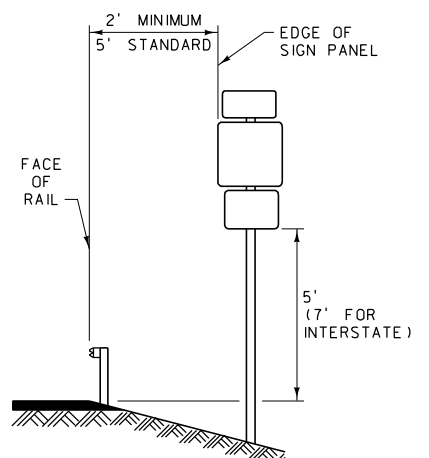
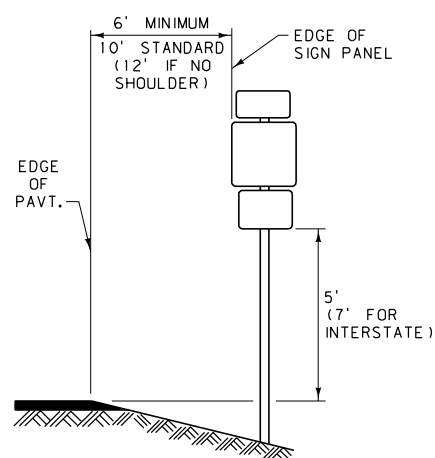

CLEAR ZONE DISTANCES
(IN FEET FROM EDGE OF DRIVING LANE)

DESIGN SPEED	DESIGN ADT	FILL SLOPES			CUT SLOPES		
		6:1 OR FLATTER	5:1 TO 4:1	3:1	3:1	4:1 TO 5:1	6:1 OR FLATTER
40 MPH OR LESS	UNDER 750	7-10	7-10	**	7-10	7-10	7-10
	750-1499	10-12	12-14	**	10-12	10-12	10-12
	1500-6000	12-14	14-16	**	12-14	12-14	12-14
	OVER 6000	14-16	16-18	**	14-16	14-16	14-16
45-50 MPH	UNDER 750	10-12	12-14	**	8-10	8-10	10-12
	750-1499	12-14	16-20	**	10-12	12-14	14-16
	1500-6000	16-18	20-26	**	12-14	14-16	16-18
	OVER 6000	18-20	24-28	**	14-16	18-20	20-22
55 MPH	UNDER 750	12-14	14-18	**	8-10	10-12	10-12
	750-1499	16-18	20-24	**	10-12	14-16	16-18
	1500-6000	20-22	24-30	**	14-16	16-18	20-22
	OVER 6000	22-24	26-32 *	**	16-18	20-22	22-24
60 MPH	UNDER 750	16-18	20-24	**	10-12	12-14	14-16
	750-1499	20-24	26-32 *	**	12-14	16-18	20-22
	1500-6000	26-30	32-40 *	**	14-18	18-22	24-26
	OVER 6000	30-32 *	36-44 *	**	20-22	24-26	26-28
65-70 MPH	UNDER 750	18-20	20-26	**	10-12	14-16	14-16
	750-1499	24-26	28-36 *	**	12-16	18-20	20-22
	1500-6000	28-32 *	34-42 *	**	16-20	22-24	26-28
	OVER 6000	30-34 *	38-46 *	**	22-24	26-30	28-30

HORIZONTAL CURVE ADJUSTMENTS
(APPLICABLE ON OUTSIDE OF CURVE ONLY)

RADIUS (FT)	DESIGN SPEED (MPH)						
	40	45	50	55	60	65	70
2860	1.1	1.1	1.1	1.2	1.2	1.2	1.3
2290	1.1	1.1	1.2	1.2	1.2	1.3	1.3
1910	1.1	1.2	1.2	1.2	1.3	1.3	1.4
1640	1.1	1.2	1.2	1.3	1.3	1.4	1.5
1430	1.2	1.2	1.3	1.3	1.4	1.4	1.4
1270	1.2	1.2	1.3	1.3	1.4	1.5	
1150	1.2	1.2	1.3	1.4	1.5		
950	1.2	1.3	1.4	1.5	1.5		
820	1.3	1.3	1.4	1.5			
720	1.3	1.4	1.5				
640	1.3	1.4	1.5				
570	1.4	1.5					
380	1.5						

TO AVOID GLARE, TURN SIGN AWAY FROM ROADWAY. ANGLE SIGNS GREATER THAN 30° FROM SHOULDER TOWARDS ROADWAY.

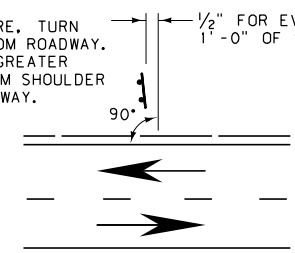

SKUEW DIAGRAM

* WHEN AN INVESTIGATION OR ACCIDENT HISTORY INDICATES A HIGH PROBABILITY OF ACCIDENTS, CLEAR ZONE DISTANCES GREATER THAN 30' MAY BE PROVIDED AS INDICATED. CLEAR ZONES MAY ALSO BE LIMITED TO 30' TO PROVIDE A CONSISTENT ROADWAY TEMPLATE WHEN EXPERIENCE WITH PREVIOUS SIMILAR PROJECTS INDICATES SATISFACTORY PERFORMANCE.

** FIXED OBJECTS, INCLUDING SIGN POSTS, SHOULD NOT BE ALLOWED IN THE VICINITY OF THE TOE OF THESE SLOPES. SEE AASHTO ROADSIDE DESIGN GUIDE FOR ADDITIONAL CONSIDERATIONS IN LOCATING SIGNS.

DETAILED DRAWING

REFERENCE DWG. NO.
STANDARD SPEC. 619-00
SECTION 619

SIGN CLEARANCES AND MOUNTING HEIGHTS

EFFECTIVE: APRIL 2006

MDT serving you with pride MONTANA DEPARTMENT OF TRANSPORTATION

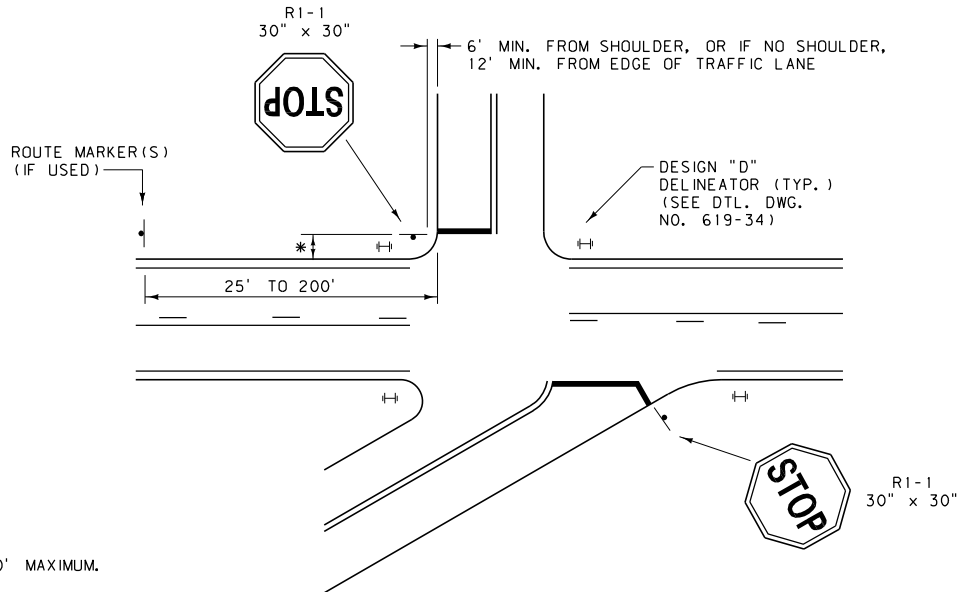

RURAL

NOTES:

* 6' MINIMUM; 50' MAXIMUM.

PLACE R1-1 SIGN AT THE BEGINNING OF CURB RADIUS OR SHOULDER RADIUS, OR 4 FEET MIN. IN ADVANCE OF THE MARKED OR UNMARKED CROSSWALK.

SEE PLANS FOR FINAL SIGNING AND PAVEMENT MARKING LOCATIONS.

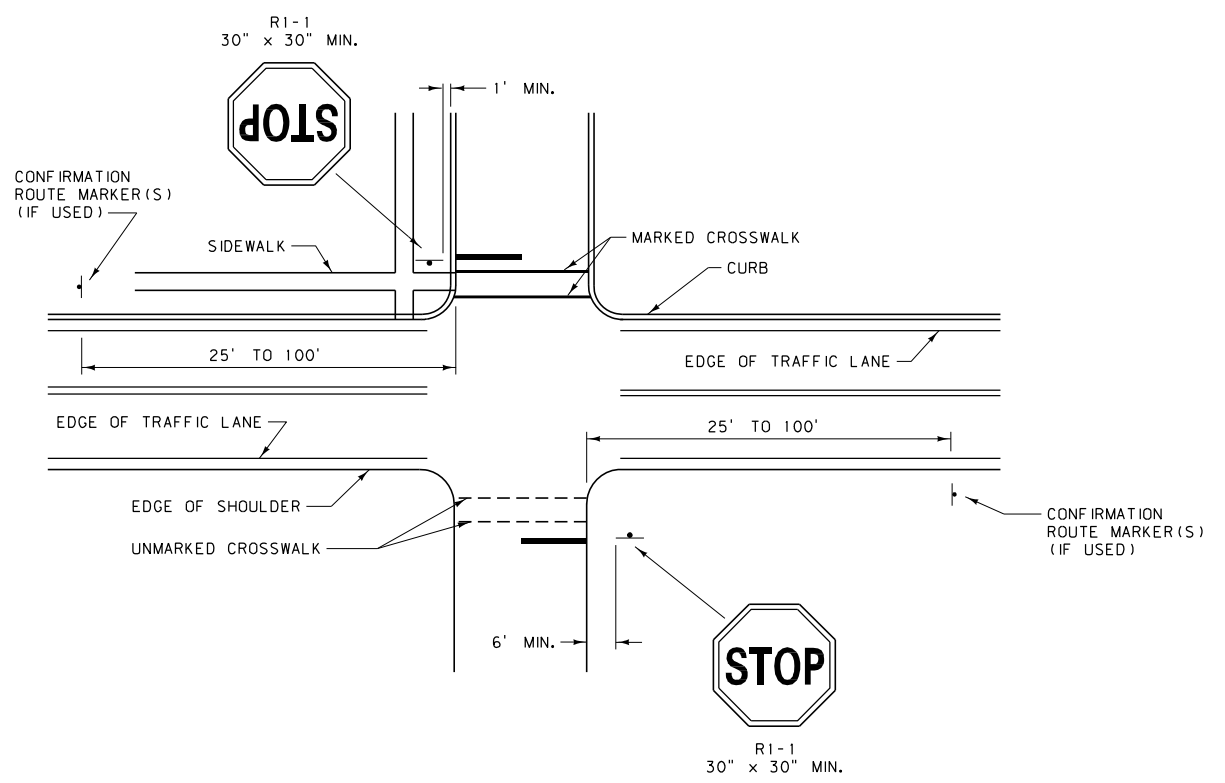

URBAN

DETAILED DRAWING	
REFERENCE STANDARD SPEC. SECTION 619	DWG. NO. 619-02
TYPICAL RURAL AND URBAN APPROACHES	
EFFECTIVE: FEBRUARY 2005	
 MONTANA DEPARTMENT OF TRANSPORTATION <i>servicing you with pride</i>	

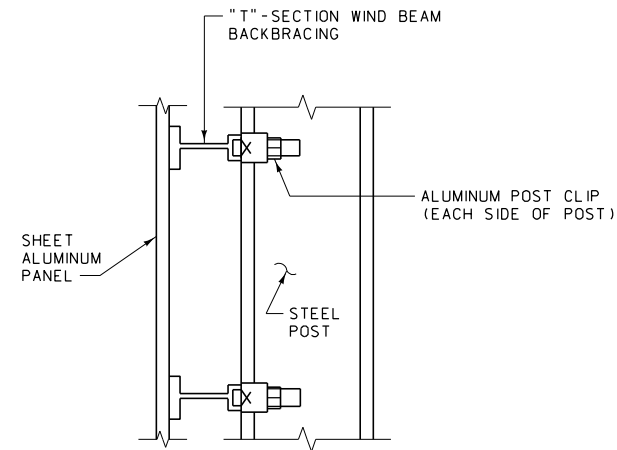

BACKBRACE DETAIL

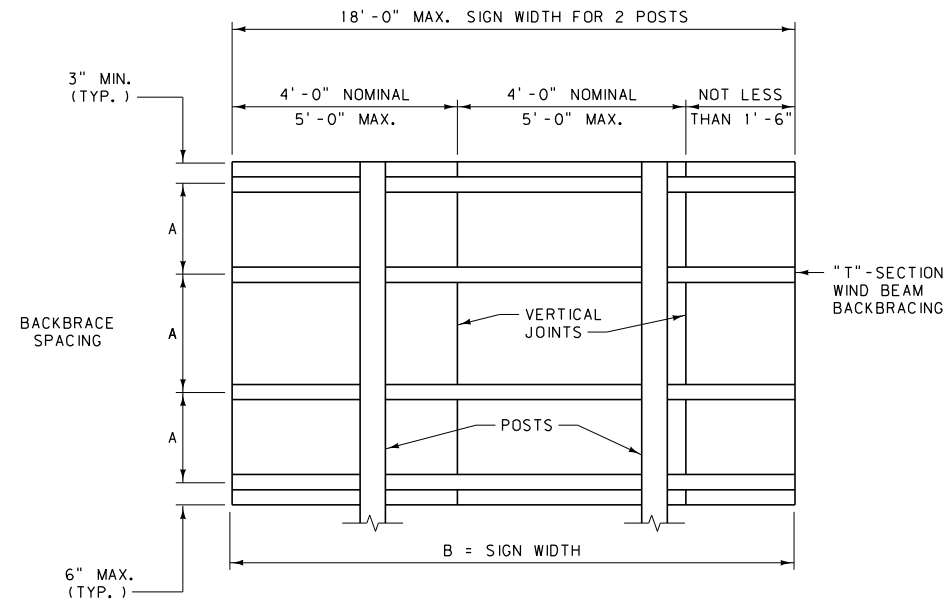

MAXIMUM BACKBRACE SPACING "A"	MAXIMUM WIDTH "B"	
	2 POST	3 POST
1' - 8"	18' - 0"	27' - 0"
1' - 10"	17' - 0"	25' - 8"
2' - 0"	16' - 6"	24' - 8"
2' - 6"	14' - 9"	22' - 0"
3' - 0"	13' - 6"	20' - 0"
3' - 6"	12' - 6"	18' - 6"

FOR ALUMINUM PLATE THICKNESS INFORMATION SEE SECTION 704.01 OF THE STANDARD SPECIFICATIONS.

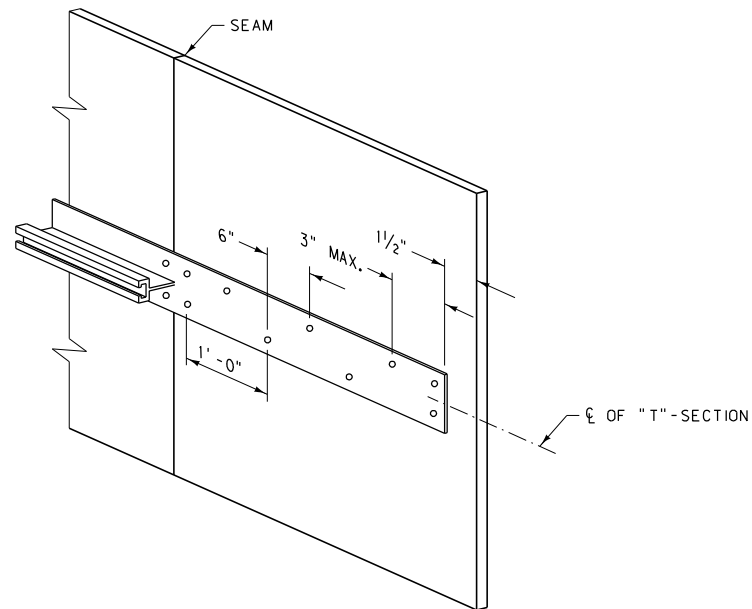

RIVET SPACING DETAIL

LOCATE RIVETS AT 6" ALTERNATE CENTERS ON HORIZONTAL EXTRUDED "T"-SECTION.

DOUBLE RIVETS (TOP AND BOTTOM OR LEFT AND RIGHT OF EXTRUDED "T"-SECTION) AT HORIZONTAL AND VERTICAL JOINTS IN SHEET ALUMINUM FACE AND AT ENDS OF EXTRUDED "T"-SECTION.

COLOR RIVET HEADS TO MATCH ADJACENT SHEETING.

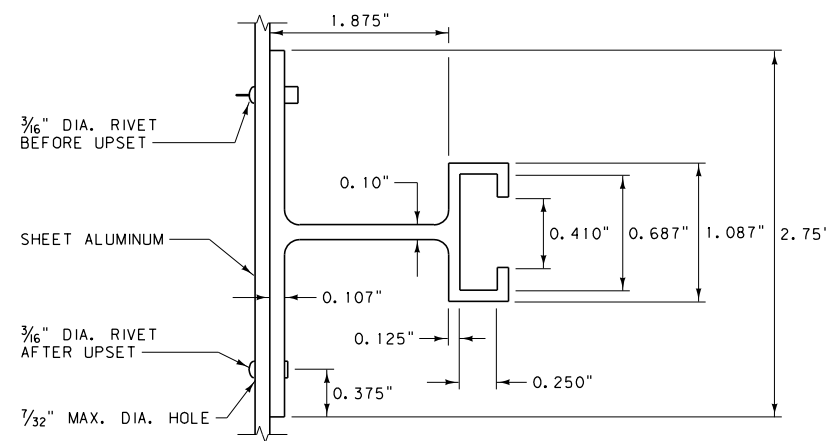

EXTRUDED "T"-SECTION BACKBRACE

NOTES:

CONFORM ALL ALUMINUM SIGNS TO SECTIONS 619, 704.01.1 AND 704.01.2 OF THE STANDARD SPECIFICATIONS.

FOR SIGNS 4'-0" HIGH BY 6'-0" LONG OR LESS USE A SINGLE SHEET OF ALUMINUM.

DO NOT USE HORIZONTAL JOINTS ON SIGNS 6'-0" IN HEIGHT AND SMALLER. THE MINIMUM SHEET WIDTH IS 1'-6".

SIGNS OVER 6'-0" HIGH MAY HAVE HORIZONTAL AND VERTICAL JOINTS. THE MINIMUM SHEET SIZE IS 1'-6" WIDE BY 1'-6" HIGH.

CLEAN AND DRY POST CLIP NUTS, THEN TORQUE TO 225 INCH POUNDS.

LOCATE ALL HORIZONTAL JOINTS AT A "T"-SECTION.

NO SPLICES ARE ALLOWED IN EXTRUDED "T"-SECTIONS.

USE SCREWS, BOLTS AND LOCKWASHERS THAT ARE ALUMINUM ALLOY MEETING ASTM B 211 FOR ALLOY 2024-T4, STAINLESS STEEL, OR CADMIUM PLATED STEEL MEETING ASTM B 766.

USE ONLY ALUMINUM RIVETS.

THE MAXIMUM GAP BETWEEN INDIVIDUAL SIGN PANELS AT JOINTS IS 1/16" AT ANY POINT.

THE ENGINEER MAY APPROVE ADDITIONAL METHODS TO PREVENT LIGHT LEAKAGE THROUGH SIGN PANEL SEAMS.

DETAILED DRAWING	
REFERENCE STANDARD SPEC. SECTION 619, 704	DWG. NO. 619-04
ALUMINUM SHEET INCREMENT SIGN CONSTRUCTION DETAILS	
EFFECTIVE: FEBRUARY 2005	
 MONTANA DEPARTMENT OF TRANSPORTATION <i>-serving you with pride</i>	

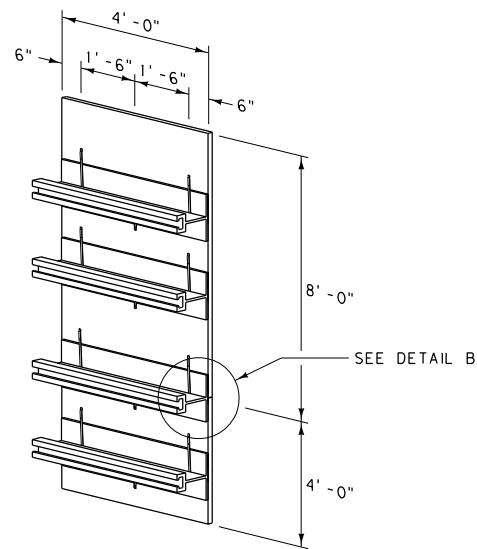
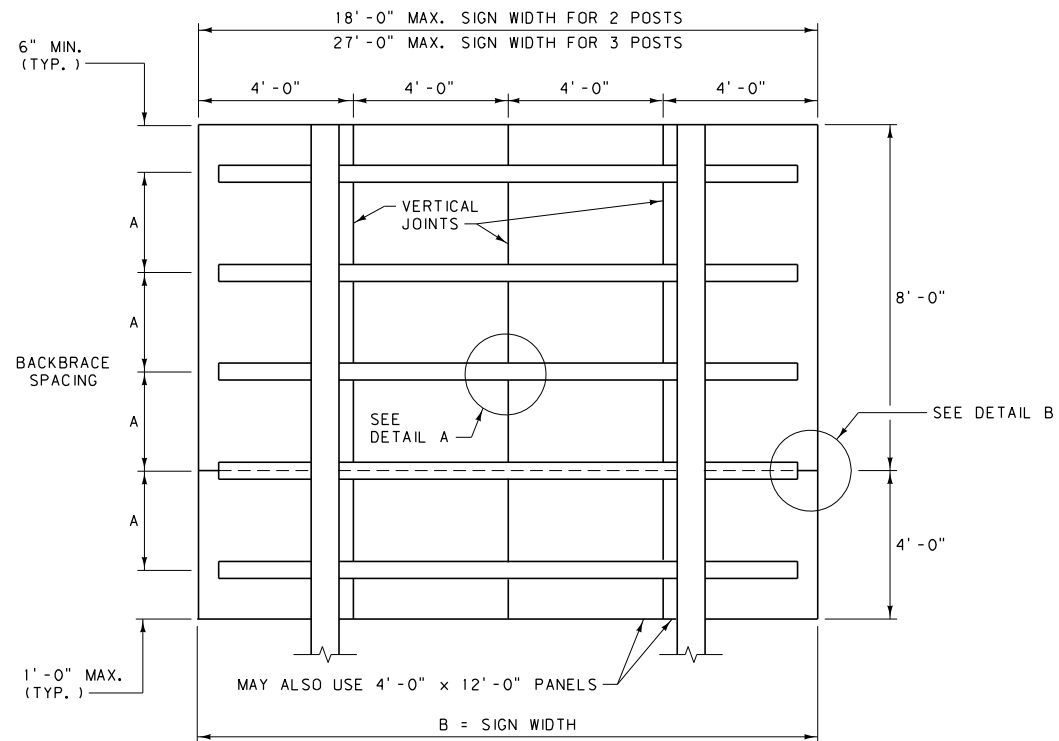

ALUMINUM CLIP PLACEMENT

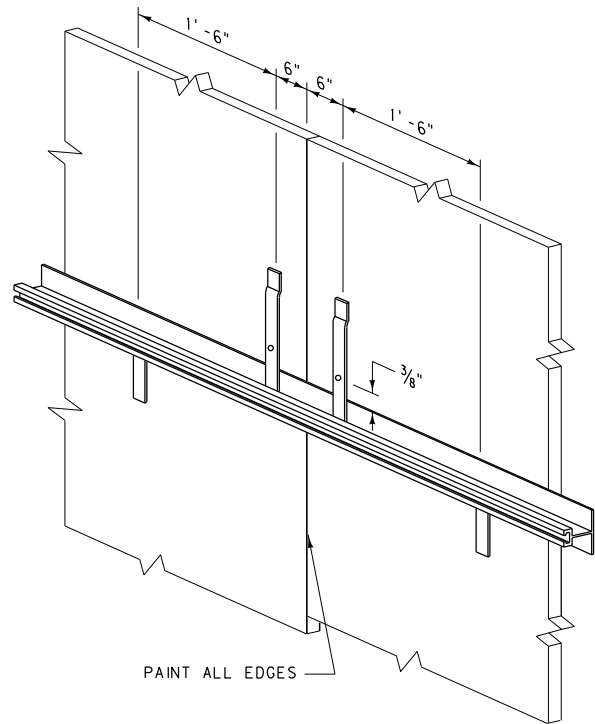
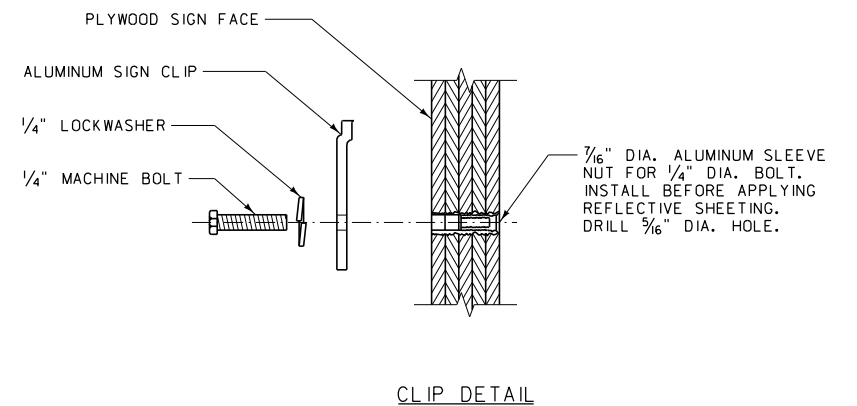

DETAIL A
VERTICAL JOINT

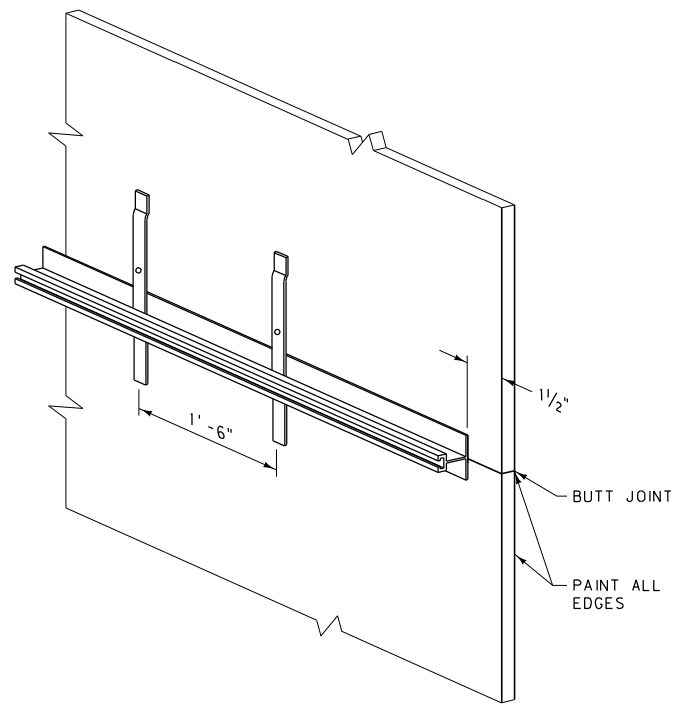

DETAIL B
HORIZONTAL JOINT

BACKBRACING TABLE - PLYWOOD SIGNS		
MAXIMUM BACKBRACE SPACING "A"	MAXIMUM WIDTH "B"	
	2 POST	3 POST
1' - 8"	18' - 0"	27' - 0"
1' - 10"	17' - 0"	25' - 8"
2' - 0"	16' - 6"	24' - 8"
2' - 6"	14' - 9"	22' - 0"
3' - 0"	13' - 6"	20' - 0"
3' - 6"	12' - 6"	18' - 6"

NOTES:

CONFORM ALL PLYWOOD SIGNS TO SECTIONS 619, 704.01.3 AND 704.02.2 OF THE STANDARD SPECIFICATIONS.

ON SIGNS 4'-0" HIGH AND GREATER, DO NOT USE ANY PANELS LESS THAN 4'-0" IN HEIGHT.

DO NOT USE HORIZONTAL JOINTS ON SIGNS LESS THAN 4'-0" IN HEIGHT.

FOR SIGNS WITH WIDTHS THAT ARE NOT IN MULTIPLES OF 4'-0", PLACE THE ODD LENGTH PANEL ON THE INSIDE EDGE.

FOR SIGNS OVER 10'-0" IN HEIGHT, THE FULL HEIGHT MAY BE OBTAINED WITH PANELS HAVING A FACTORY SCARFED JOINT IN LIEU OF USING STANDARD LENGTH PANEL AS SHOWN.

THE MINIMUM SIZE PANEL IS 1'-6" WIDE BY 4'-0" HIGH.

CONSTRUCT PLYWOOD SIGNS OF ONE PIECE OF PLYWOOD UNLESS THE PLANS SPECIFY OTHERWISE FOR SPECIAL DESIGN SIGNS.

DETAILED DRAWING	
REFERENCE STANDARD SPEC. SECTION 619, 704	DWG. NO. 619-06
PLYWOOD SHEET INCREMENT GUIDE SIGN CONSTRUCTION DETAILS	
EFFECTIVE: FEBRUARY 2005	
 serving you with pride	MONTANA DEPARTMENT OF TRANSPORTATION

MOUNTING DETAILS

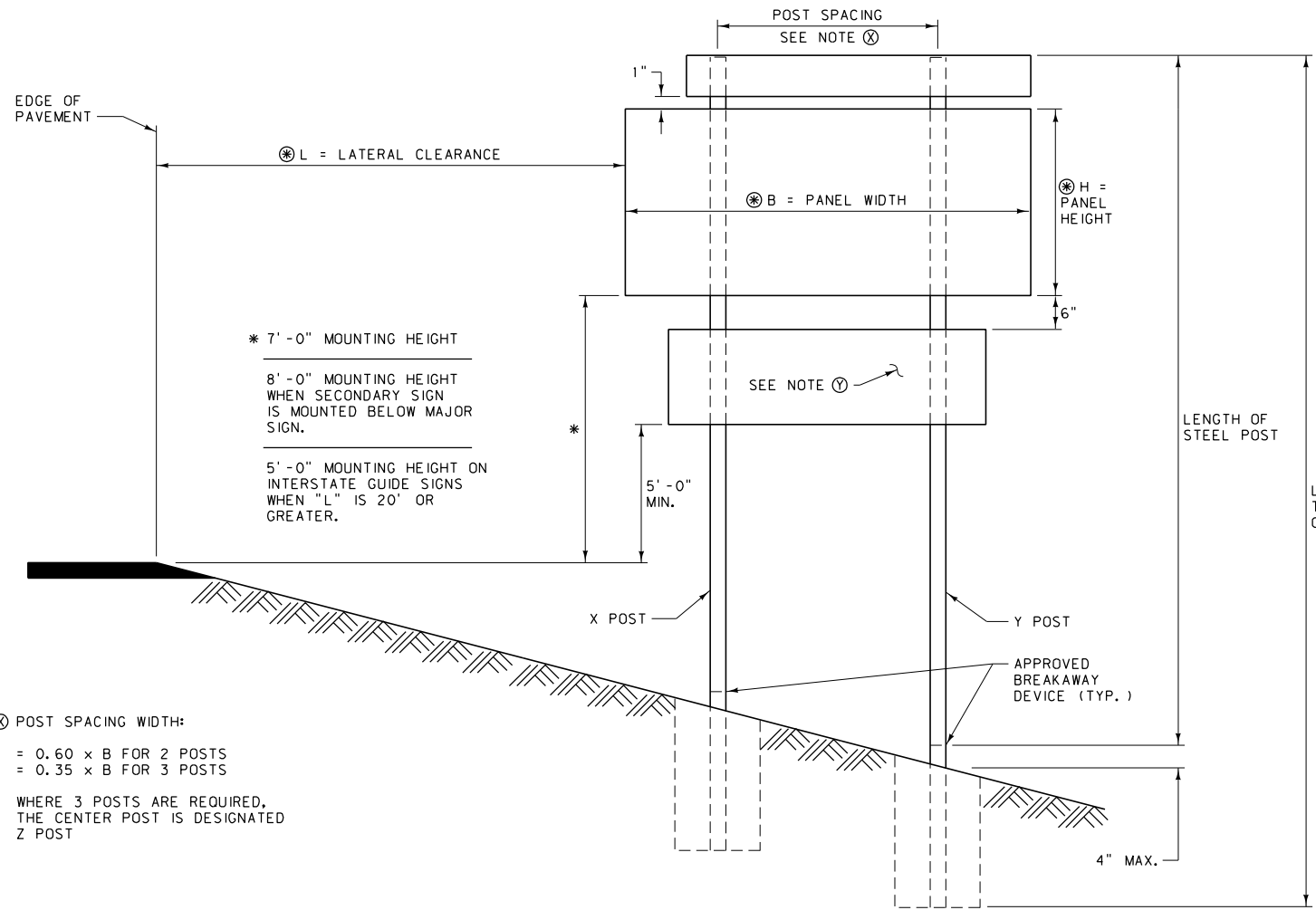

⊗ POST SPACING WIDTH:
= 0.60 x B FOR 2 POSTS
= 0.35 x B FOR 3 POSTS
WHERE 3 POSTS ARE REQUIRED,
THE CENTER POST IS DESIGNATED
Z POST

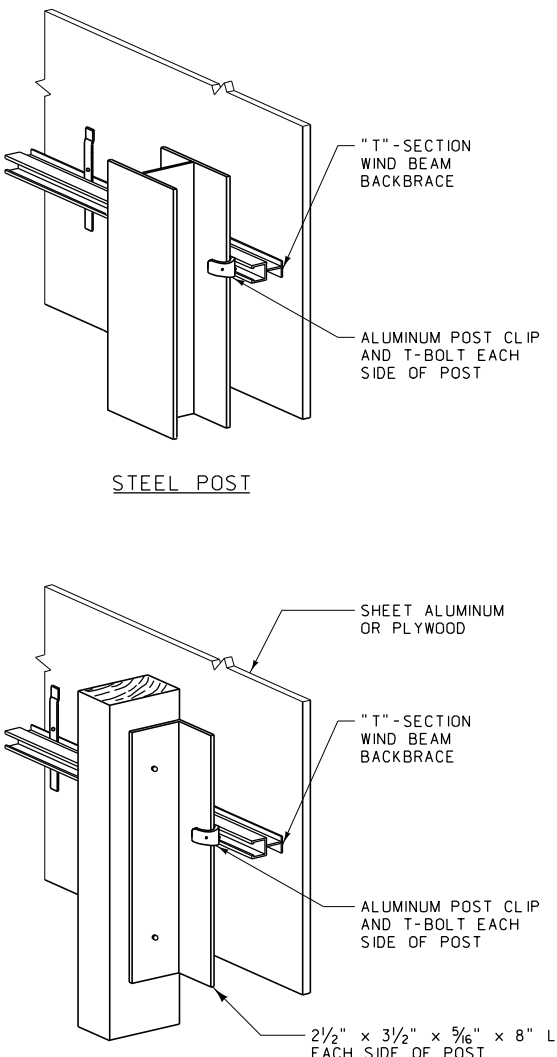
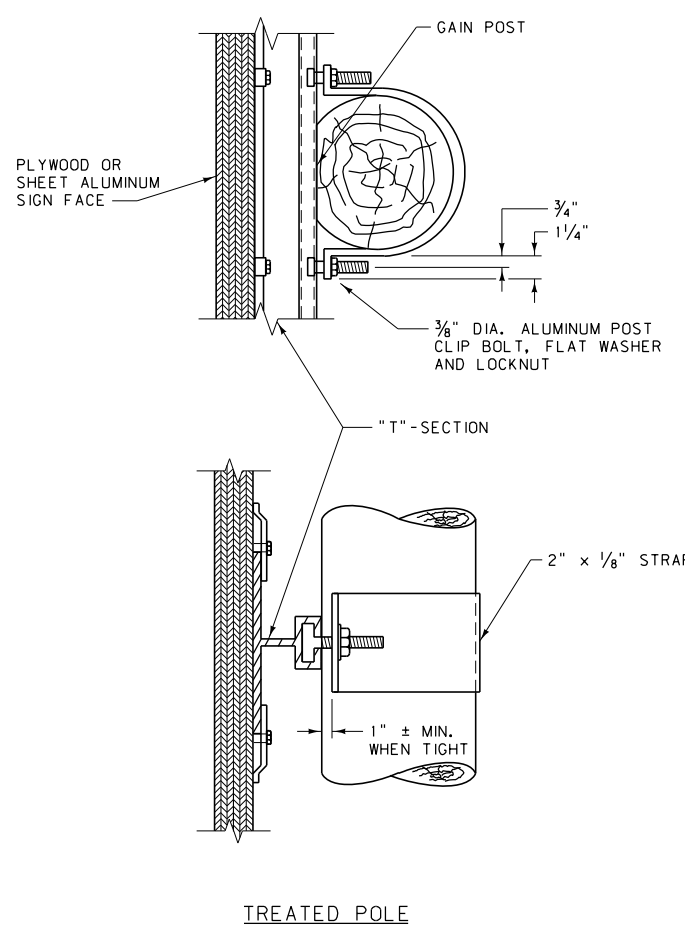

NOTES:

MOUNTING SYSTEMS SHOWN ARE TYPICAL. OTHER SYSTEMS MAY BE APPROVED BY THE ENGINEER.

ALL STEEL HARDWARE MUST BE GALVANIZED, STAINLESS, OR CADMIUM PLATED.

GAIN THE TOP HALF OF WOOD POLES ACCORDING TO THE TABLE ON DTL. DWG. NO. 619-20.

SEE THE SIGNING QUANTITIES FOR THE TYPES OF POSTS AND FOUNDATIONS.

MOUNT ONE-PANEL PLYWOOD SIGNS DIRECTLY TO WOOD POLES OR POSTS, WHEN SPECIFIED IN THE PLANS, BY BOLTING THROUGH THE SIGN PLATE AND THE POLE WITH CADMIUM PLATED BOLTS AS REQUIRED BY THE DETAILED DRAWINGS, SPECIFICATIONS AND DESIGN. USE "T"-SECTION WIND BEAMS WHEN REQUIRED BY DTL. DWG. NO. 619-06.

⊙ SUSPEND LARGE SUPPLEMENTAL SIGNS, ADDED AFTER INITIAL SIGN INSTALLATION, FROM MAJOR SIGN PANEL OR BACKBRACING. ATTACHMENT TO MULTIPLE POSTS/POLES IS NOT ALLOWED.

USE POST SPACING, POST SIZE AND BREAKAWAY DEVICES SPECIFIED IN THE PLANS AND IN THE SPECIFICATIONS. FOR INFORMATION REGARDING APPROPRIATE BREAKAWAY DEVICES FOR NEW INSTALLATIONS NOT SUPPORTED BY THE PLANS, CONTACT THE TRAFFIC UNIT.

IN LOCATING SIGNS, AVOID PLACING POSTS IN DITCH BOTTOMS WHERE THEY WOULD IMPEDE DRAINAGE.

⊗ DIMENSIONS ARE SPECIFIED IN THE SIGNING PLANS.

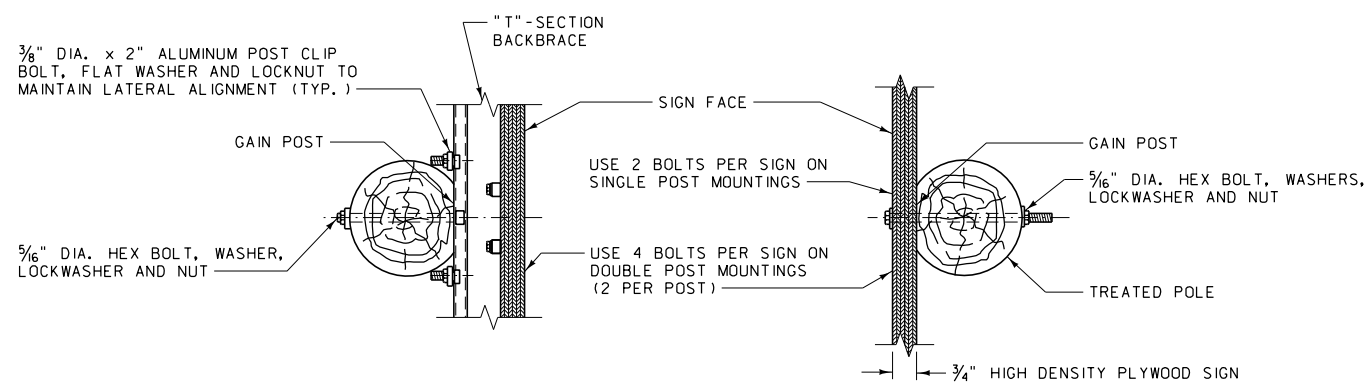

DOUBLE POLE MOUNT

TREATED POLE SINGLE OR DOUBLE
(USED WHEN "T"-BAR WIND BEAMS NOT REQUIRED)

DETAILED DRAWING	
REFERENCE STANDARD SPEC. SECTION 619, 704	DWG. NO. 619-08
GUIDE SIGN CLEARANCE AND MOUNTING DETAILS	
EFFECTIVE: FEBRUARY 2005	
 MONTANA DEPARTMENT OF TRANSPORTATION <i>-serving you with pride-</i>	

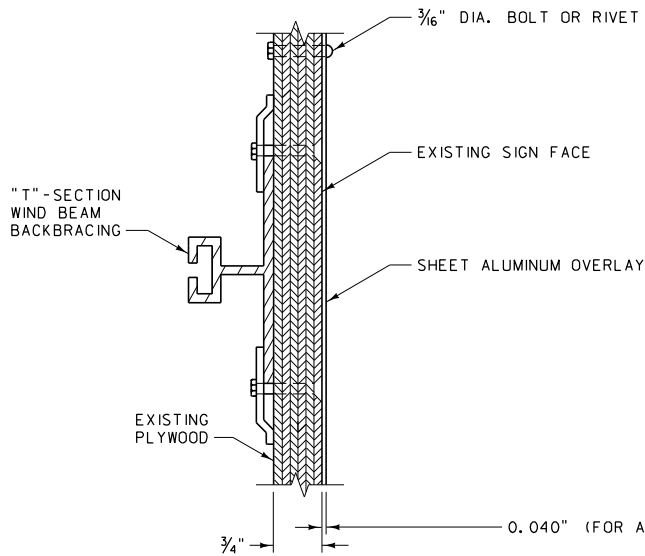

EXISTING PLYWOOD SIGNS

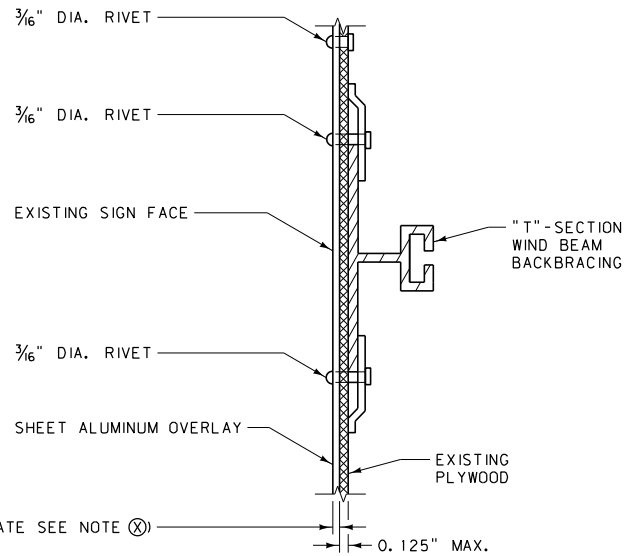

EXISTING ALUMINUM SIGNS

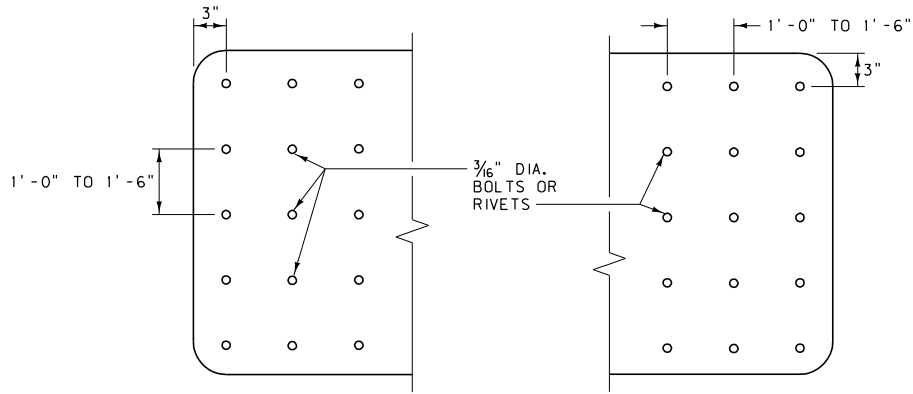

FASTENER PATTERN

NOTES:

REMOVE ALL RAISED LETTERS, NUMERALS, SYMBOLS, BORDERS AND PREVIOUS SIGN OVERLAYS TO BE REPLACED, AND CLEAN SIGN FACE TO A SMOOTH SURFACE BEFORE OVERLAYING.

ALL LETTERS, NUMERALS, SYMBOLS AND BORDERS ARE TYPE "C" CUTOUT UNLESS OTHERWISE SPECIFIED, AND APPLIED TO THE BACKGROUND SHEETING PRIOR TO FIELD APPLICATION OF THE SIGN.

THE SIZE OF ALL GUIDE SIGN OVERLAYS AND LEGENDS MUST BE VERIFIED BY THE ENGINEER PRIOR TO FABRICATION.

⊗ AN ADHESIVE-BACKED SHEETING MAY BE USED AS AN ALTERNATIVE ON SIGN WIDTHS OF 6'-0" OR LESS IF IT IS PREFABRICATED TO A MINIMUM THICKNESS OF 0.005 INCHES AND CONSTRUCTED OF PREAPPLIED REFLECTIVE SHEETING ON ADHESIVE-BACKED ALUMINUM. APPLY ADHESIVE-BACKED OVERLAY SHEETING WHEN AIR AND SURFACE TEMPERATURES ARE ABOVE 50°F (10°C). DO NOT USE THIS TYPE OF OVERLAY MATERIAL ON OVERHEAD SIGNS.

PROVIDE A MINIMUM REFLECTIVE SHEETING INTENSITY OF ENGINEERING GRADE, MEETING THE REQUIREMENTS OF THE STANDARD SPECIFICATIONS, UNLESS SPECIFIED OTHERWISE.

APPLY ALL MATERIALS IN ACCORDANCE WITH THE MANUFACTURER'S SPECIFICATIONS AND RECOMMENDATIONS.

SEE THE STANDARD SPECIFICATIONS FOR ADDITIONAL REQUIREMENTS.

USE ALUMINUM ALLOY TYPE 6061-T6 OR AA5052-H38. CONVERSION COAT ALL ALUMINUM WITH A PROCESS SUCH AS ALODINE 1200 (OR EQUAL), AND RINSE AND DRY THOROUGHLY. PROTECT IT FROM SOIL BY ACCEPTABLE METHODS.

SIGN OVERLAYS MAY REQUIRE REMOVAL OF THE SIGN FROM THE POSTS TO AVOID PROJECTING BOLT HEADS. DO NOT LEAVE WARNING AND REGULATORY SIGNS TO BE OVERLAYED UNDISPLAYED FOR MORE THAN ONE (1) HOUR DURING DAYLIGHT. DO NOT LEAVE GUIDE SIGNS UNDISPLAYED FOR MORE THAN TEN (10) HOURS DURING DAYLIGHT. INSURE SIGNS TO BE OVERLAYED ARE OPERATIONAL PRIOR TO DARKNESS.

OVERLAY SIGNS SMALLER THAN 4'-0" x 6'-0" WITH ONE PANEL OF MATERIAL. FOR SEAMS IN LARGE OVERLAYS, USE RIVETS OR BOLTS SPACED AS SHOWN ON THIS DRAWING AND PLACE PARALLEL TO AND NO MORE THAN 3" Laterally FROM THE SEAM.

DETAILED DRAWING	
REFERENCE STANDARD SPEC. SECTION 619	DWG. NO. 619-10

SHEET ALUMINUM OVERLAY

EFFECTIVE: FEBRUARY 2005

NOTES:

USE TUBULAR POSTS FOR SINGLE POST MOUNTED SIGNS ONLY.

BOLT WITH HEX HEAD, HEX NUT AND 3 WASHERS EACH LOCATION. SEE TABLE FOR BOLT DIAMETER AND TORQUE. SEE PROCEDURE FOR BASE CONNECTION ASSEMBLY.

ALL BOLTS ARE ASTM A 325.

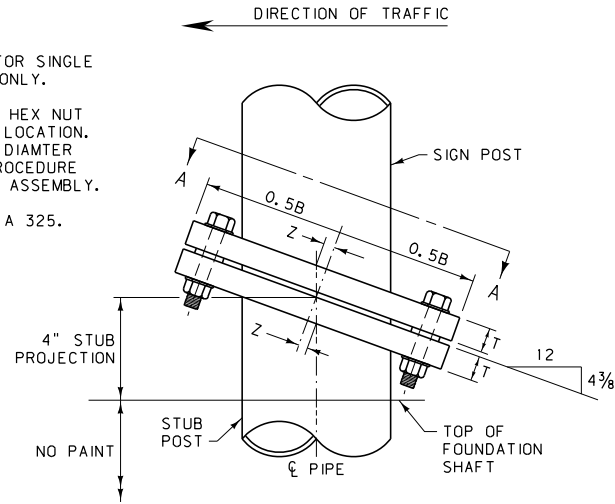

SIGN POST AND STUB POST DETAILS

SECTIONS SHOWN ARE FOR INSTALLATION ON RIGHT SHOULDER AND IN GORE. PLATE SLOT BEVELS ARE OPPOSITE HAND FROM THAT SHOWN FOR INSTALLATIONS ON LEFT SHOULDER.

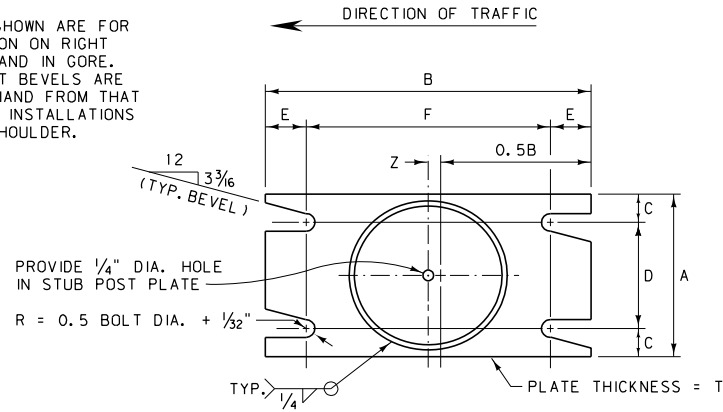

**SECTION A-A
BASE PLATE DETAIL**

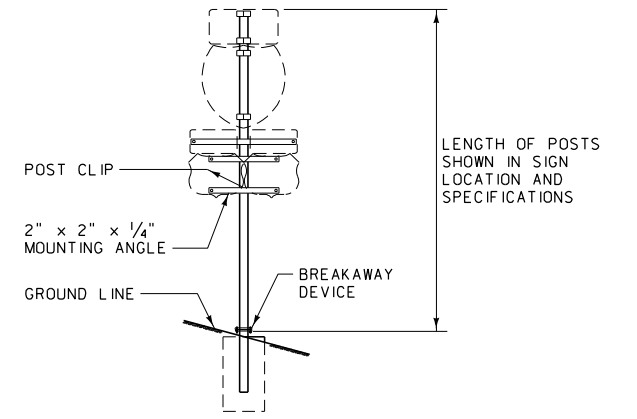

TYPICAL SIGN ELEVATION
FOR DETAILS OF MOUNTING ANGLES SEE DETAILED DRAWING NUMBER 619-16 AND BELOW.

PROCEDURE FOR BASE CONNECTION ASSEMBLY

1. ASSEMBLE POST TO STUB WITH BOLTS AND ONE FLAT WASHER BETWEEN PLATES.
2. SHIM AS REQUIRED TO PLUMB POST.
3. TIGHTEN BOLTS IN A SYSTEMATIC ORDER TO THE PRESCRIBED TORQUE (SEE TABLE BELOW).
4. LOOSEN EACH BOLT AND RETIGHTEN TO PRESCRIBED TORQUE IN THE SAME ORDER AS ORIGINAL TIGHTENING. DO NOT OVERTIGHTEN.
5. BURR THREADS AT JUNCTION WITH NUT USING A CENTER PUNCH TO PREVENT NUT LOOSENING.

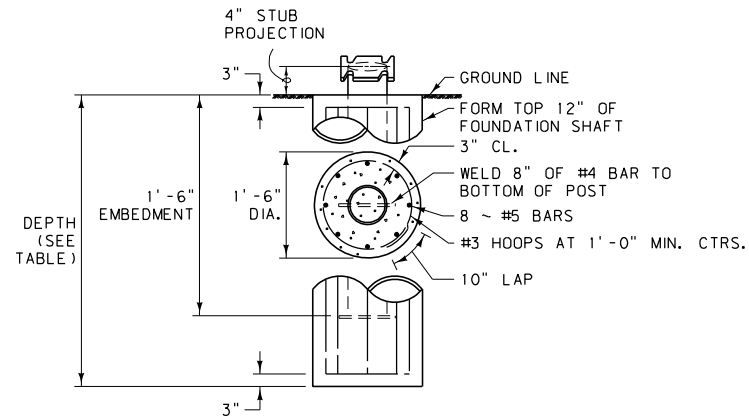

FOUNDATION SHAFT DETAIL

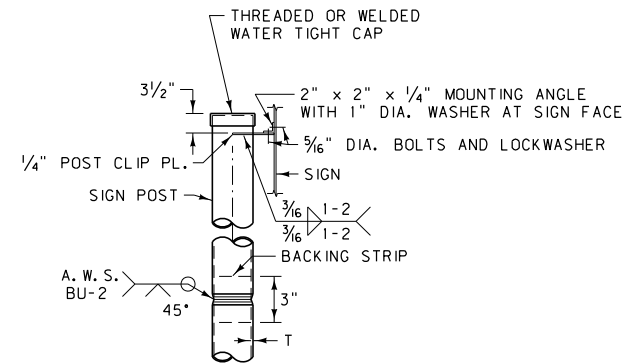

TYPICAL SPLICE

BACKING STRIP THICKNESS = T OR 5/16" MAX. LOCATE SPLICE IN TOP ONE-HALF OF POST.

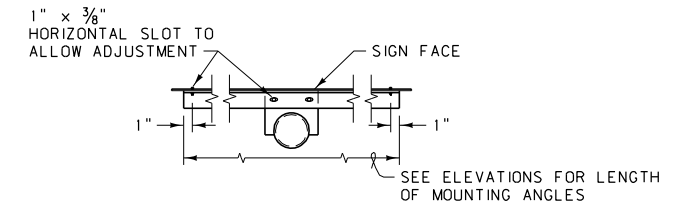

POST CLIP DETAILS

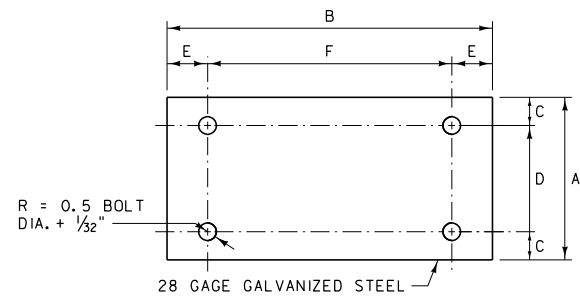

KEEPER PLATE DETAIL

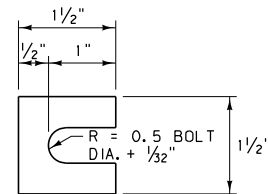

SHIM DETAIL

FURNISH TWO 0.012" ± THICK AND TWO 0.032" ± THICK SHIMS PER POST. USE SHIMS FABRICATED FROM BRASS SHIM STOCK OR STRIP CONFORMING TO ASTM B 36.

NOTES:

USE STEEL PIPE CONFORMING TO THE REQUIREMENTS OF ASTM A 53, TYPE E OR S, GRADE B OR A 500, GRADE B.

USE CLASS "A" OR "D" CONCRETE WITH A WOOD FLOAT FINISH ON TOP. FORM TOP TWELVE INCHES OF FOUNDATION.

SEE THE STANDARD SPECIFICATIONS FOR REQUIREMENTS GOVERNING STRUCTURAL STEELS AND THEIR FABRICATION.

SUBMIT SHOP PLANS FOR APPROVAL PRIOR TO FABRICATION.

FOR SIGN PLACEMENT AND DETAILS SEE THE SIGNING DETAILED DRAWINGS.

GALVANIZE PIPE AS PER AASHTO M 111.

EXCEPT AS OTHERWISE APPROVED BY THE ENGINEER, PAINT STRUCTURAL STEEL WITH ONE SHOP COAT AND ONE FIELD COAT OF ZINC RICH BASED PAINT AND ONE FIELD COAT OF ALUMINUM PAINT AS SPECIFIED IN THE STANDARD SPECIFICATIONS, ON ALL SURFACES NOT IN CONTACT WITH THE CONCRETE.

FRANGIBLE BOLT BREAKAWAY SYSTEMS APPROVED BY FHWA ARE ALLOWED TO BE USED IN PLACE OF THE DESIGN SHOWN HERE AS AN EQUAL OPTION (PER ENGINEER'S APPROVAL).

TABLE OF WEIGHTS		
NOMINAL PIPE DIA.	NOMINAL WEIGHT (LB./FT.) OF PIPE	WEIGHT OF EACH BREAKAWAY DEVICE & STUB POST (LB.)
3"	7.58	28.03
3 1/2"	9.11	35.85
4"	10.79	38.44
5"	14.62	61.51
6"	18.97	81.54

BASE CONNECTION DATA											FOUNDATION	
NOMINAL PIPE DIA.	BOLT SIZE	BOLT TORQUE	A	B	C	D	E	F	T	Z	FOOTING DIAMETER	FOOTING DEPTH
3"	1/2" DIA. x 2 1/2"	240 IN. LB.	4 1/2"	7 1/2"	1"	2 1/2"	3/4"	6"	3/4"	5/16"	1' - 6"	3' - 0"
3 1/2" & 4"	1/2" DIA. x 2 1/2"	240 IN. LB.	5 1/2"	8 1/2"	1"	3 1/2"	3/4"	7"	3/4"	5/16"	1' - 6"	3' - 0"
5"	5/8" DIA. x 3 1/4"	480 IN. LB.	6 1/2"	9 3/4"	1 1/4"	4"	7/8"	8"	1"	3/8"	1' - 6"	4' - 0"
6"	3/4" DIA. x 3 1/2"	780 IN. LB.	7 1/2"	11 1/4"	1 1/4"	5"	1"	9 1/4"	1"	3/8"	1' - 6"	4' - 6"

DETAILED DRAWING

REFERENCE DWG. NO.
STANDARD SPEC. 619-12
SECTION 556, 619, 704

**TUBULAR SIGN POST
DETAILS**

EFFECTIVE: FEBRUARY 2005

MDT MONTANA DEPARTMENT
OF TRANSPORTATION
servicing you with pride

BASE CONNECTION DATA										FUSE PLATE DATA										FOUNDATION DATA					
POST SIZE	BOLT SIZE	BOLT TORQUE	DIMENSIONS							BREAKAWAY DEVICE (LB.)	DIMENSIONS								BOLT DIA.	FUSE DEVICE (LB.)	FTG. DEPTH	STUB LENGTH	FTG. DIA.	BAR C SIZE	STUB POST (LB.)
			A	B	C	D	E	t ₁	W		F	G	H	J	K	L	N	t ₃							
W4 x 13 M4 x 13	5/8" DIA. x 2 3/4"	40 FT. LB.	8 1/2"	5"	3/4"	2 3/4"	1 1/8"	3/4"	5/16"	21.58	3 3/4"	2"	1 1/8"	4"	2 1/4"	7/8"	5/8"	3/8"	5/8"	1.60	3' - 6"	2' - 0"	1' - 6"	#5	26.00
W8 x 18			12 1/2"	6 1/4"	3/4"	4"	1 1/8"	3/4"	5/16"	37.00	4 1/2"	2 1/2"	1 1/4"	5 1/4"	2 3/4"	1 1/4"	3/4"	1/2"	3/4"	3.27	5' - 6"	2' - 6"	2' - 0"	#7	45.00
W8 x 24	3/4" DIA. x 3 1/2"	65 FT. LB.	13"	7 1/2"	3/4"	5"	1 1/4"	1"	5/16"	60.86	4 3/4"	2 1/2"	1 1/2"	6"	3 1/2"	1 1/4"	3/4"	5/16"	3/4"	4.66	7' - 0"	3' - 0"	2' - 0"	#9	72.00
W12 x 30			17"	7 1/2"	7/8"	5"	1 1/4"	1"	5/16"	78.54	5 3/8"	3"	1 1/2"	6 1/2"	3 1/2"	1 1/2"	7/8"	5/16"	7/8"	5.42	8' - 0"	3' - 0"	2' - 6"	#9	90.00
S3 x 5.7	1/2" DIA. x 2 1/2"	20 FT. LB.	8"	3"	3/4"	1 1/2"	3/4"	5/8"	1/4"	10.37	3 3/8"	1 1/2"	1 1/8"	2 5/8"	1 1/2"	5/16"	1/2"	1/4"	1/2"	0.64	3' - 6"	1' - 6"	1' - 6"	#4	8.55
S4 x 7.7			8"	3"	3/4"	1 1/2"	3/4"	5/8"	1/4"	10.45	3 3/8"	1 1/2"	1 1/8"	2 5/8"	1 1/2"	5/16"	1/2"	1/4"	1/2"	0.64	3' - 6"	1' - 6"	1' - 6"	#4	11.55
S5 x 10.0	5/8" DIA. x 2 3/4"	40 FT. LB.	9 1/2"	4"	3/4"	2"	1"	3/4"	1/4"	19.08	3 3/8"	1 1/2"	1 1/8"	3"	1 7/8"	5/16"	1/2"	1/4"	1/2"	0.66	3' - 6"	1' - 6"	1' - 6"	#5	15.00

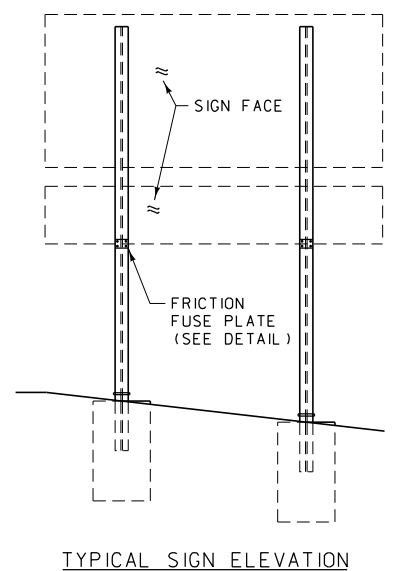

- PROCEDURE FOR BASE CONNECTION ASSEMBLY**
- ASSEMBLE POST TO STUB WITH BOLTS AND ONE FLAT WASHER BETWEEN PLATES.
 - SHIM AS REQUIRED TO PLUMB POST.
 - TIGHTEN BOLTS IN A SYSTEMATIC ORDER TO THE PRESCRIBED TORQUE (SEE TABLE).
 - LOOSEN EACH BOLT AND RETIGHTEN TO PRESCRIBED TORQUE IN THE SAME ORDER AS ORIGINAL TIGHTENING. DO NOT OVERTIGHTEN.
 - BURR THREADS AT JUNCTION WITH NUT USING A CENTER PUNCH TO PREVENT NUT LOOSENING.
- NOTE:**
ALL BOLTS MUST BE ASTM A 325 AND BE TIGHTENED BY USE OF A DIRECT TENSION INDICATING DEVICE (LOAD INDICATING WASHER) IN ACCORDANCE WITH THE MANUFACTURER'S SPECIFICATIONS.

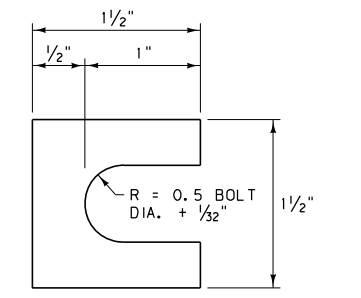
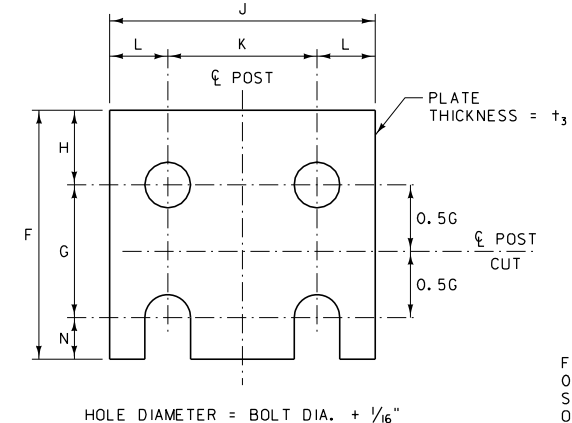
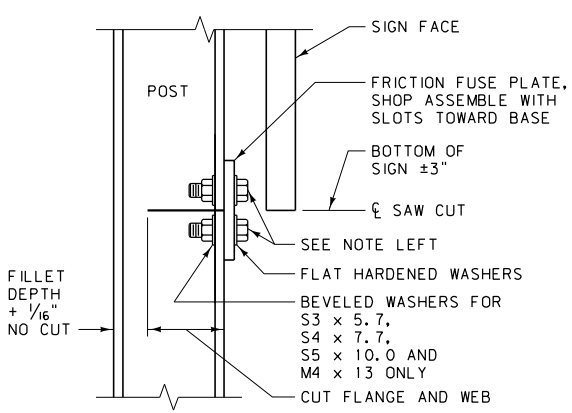

FURNISH TWO 0.012" ± THICK AND TWO 0.032" ± THICK SHIMS PER POST. USE SHIMS FABRICATED FROM BRASS SHIM STOCK OR STRIP CONFORMING TO ASTM B 36.

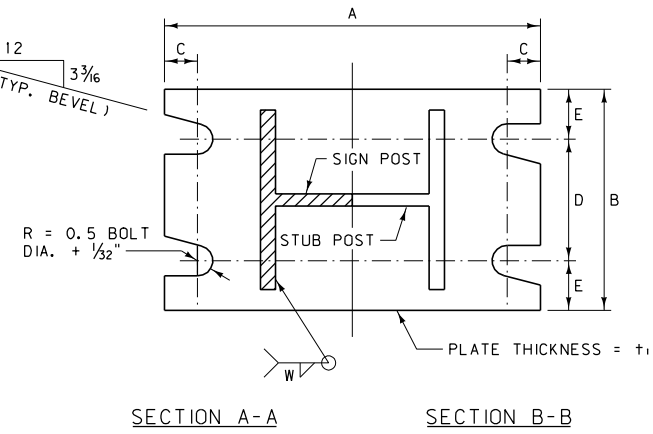
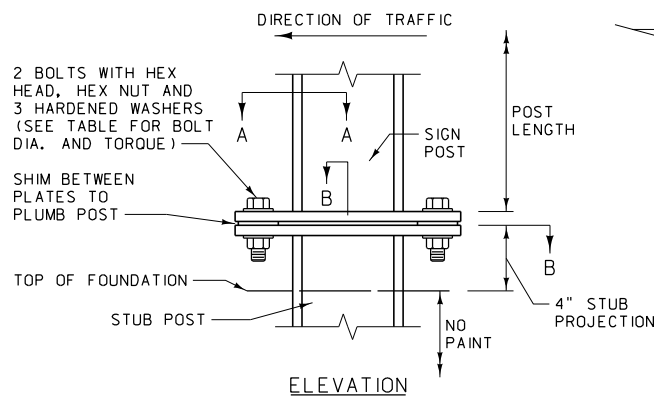

SIGN POST AND STUB POST DETAIL "A"

NOTE:
SECTIONS SHOWN ARE FOR INSTALLATIONS ON RIGHT SHOULDER AND IN GORE. PLATE SLOT BEVELS ARE OPPOSITE HAND FROM THAT SHOWN FOR INSTALLATIONS ON LEFT SHOULDER.

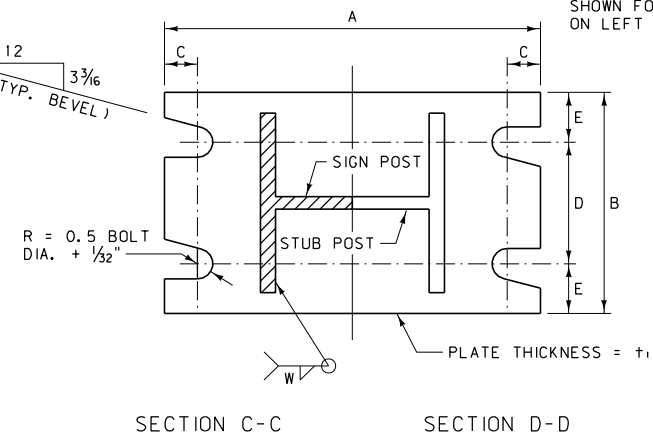
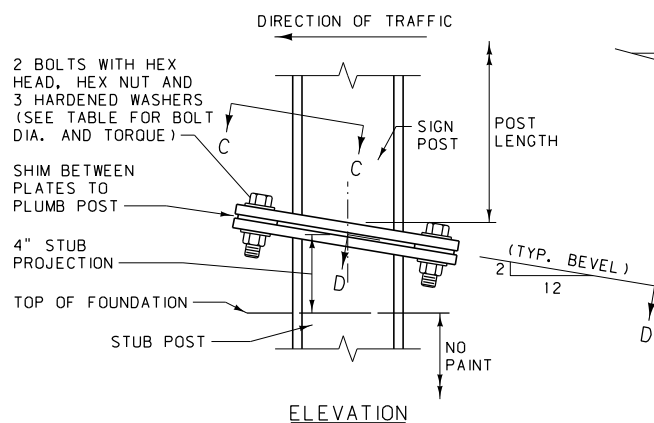

SIGN POST AND STUB POST DETAIL "B"
USE ONLY WITH SINGLE POST SIGNS

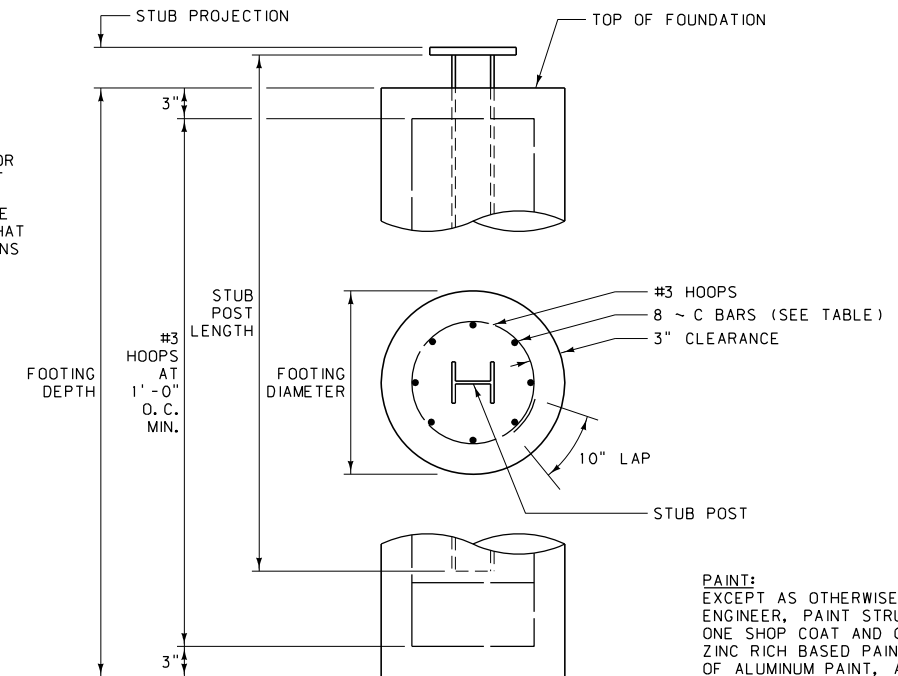

PAINT:
EXCEPT AS OTHERWISE APPROVED BY THE ENGINEER, PAINT STRUCTURAL STEEL WITH ONE SHOP COAT AND ONE FIELD COAT OF ZINC RICH BASED PAINT AND ONE FIELD COAT OF ALUMINUM PAINT, AS SPECIFIED IN THE STANDARD SPECIFICATIONS, ON ALL SURFACES NOT IN CONTACT WITH CONCRETE.

- NOTES:**
- USE CLASS "A" OR "D" CONCRETE WITH A WOOD FLOAT FINISH ON TOP. FORM TOP 12 INCHES OF FOUNDATION.
 - SEE THE STANDARD SPECIFICATIONS FOR REQUIREMENTS GOVERNING STRUCTURAL STEELS AND THEIR FABRICATIONS. TO AVOID OVERSIGHT, NOTE THESE REQUIREMENTS ON THE SHOP DRAWINGS.
 - SUBMIT SHOP PLANS FOR APPROVAL BEFORE FABRICATION IS BEGUN.
 - THE WEIGHT OF STEEL POSTS IS COMPUTED BY TAKING THE LENGTH OF THE POST TIMES THE NOMINAL WEIGHT PER FOOT PLUS THE WEIGHT OF THE BREAKAWAY DEVICE, FUSE DEVICE AND STUB POST AS SHOWN IN THE TABLE.
 - FOR GUIDE SIGN PLACEMENT AND DETAILS, SEE SIGNING DTL. DWG. NO. 619-08.
 - FRANGIBLE BOLT BREAKAWAY SYSTEMS APPROVED BY FHWA ARE ALLOWED TO BE USED IN PLACE OF THE DESIGN SHOWN HERE AS AN EQUAL OPTION (PER ENGINEER'S APPROVAL).

DETAILED DRAWING	
REFERENCE STANDARD SPEC. SECTION 619	DWG. NO. 619-13
BREAKAWAY AND FOUNDATION DETAILS FOR MULTIPLE GUIDE SIGN SUPPORTS	
EFFECTIVE: FEBRUARY 2005	
MONTANA DEPARTMENT OF TRANSPORTATION <small>servicing you with pride</small>	

SIGNS WITHOUT BACKBRACING
(SEE PLANS FOR BACKBRACING REQUIREMENTS)

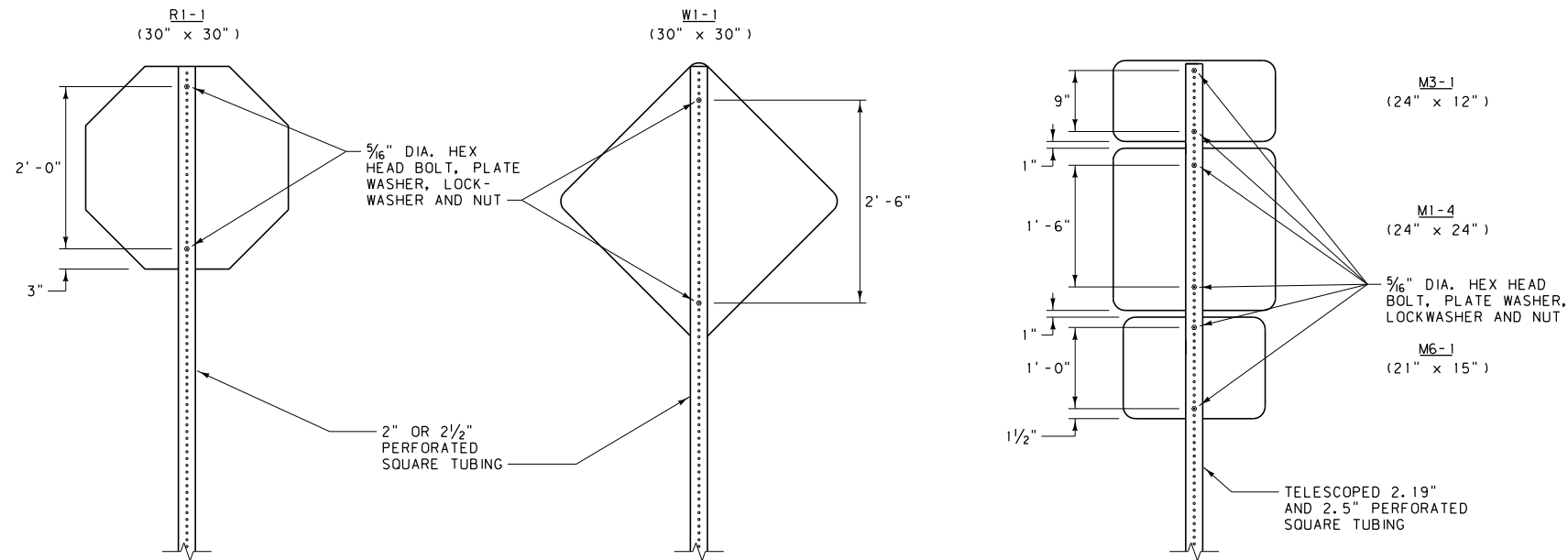

STREET NAME SIGN INSTALLATION

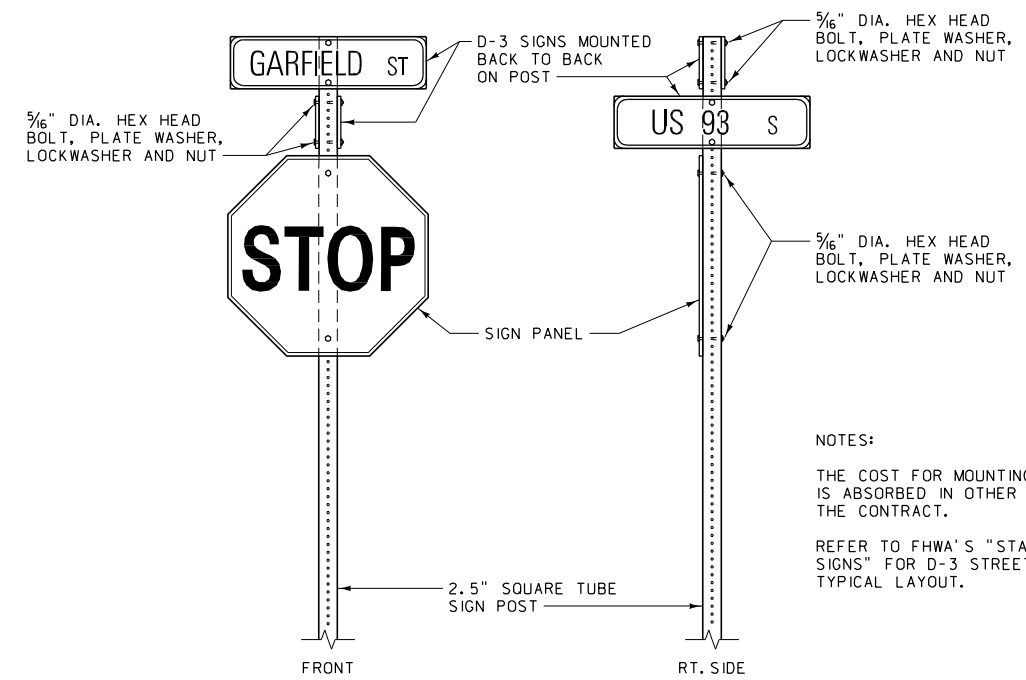

SIGNS WITH BACKBRACING
(SEE PLANS FOR BACKBRACING REQUIREMENTS)

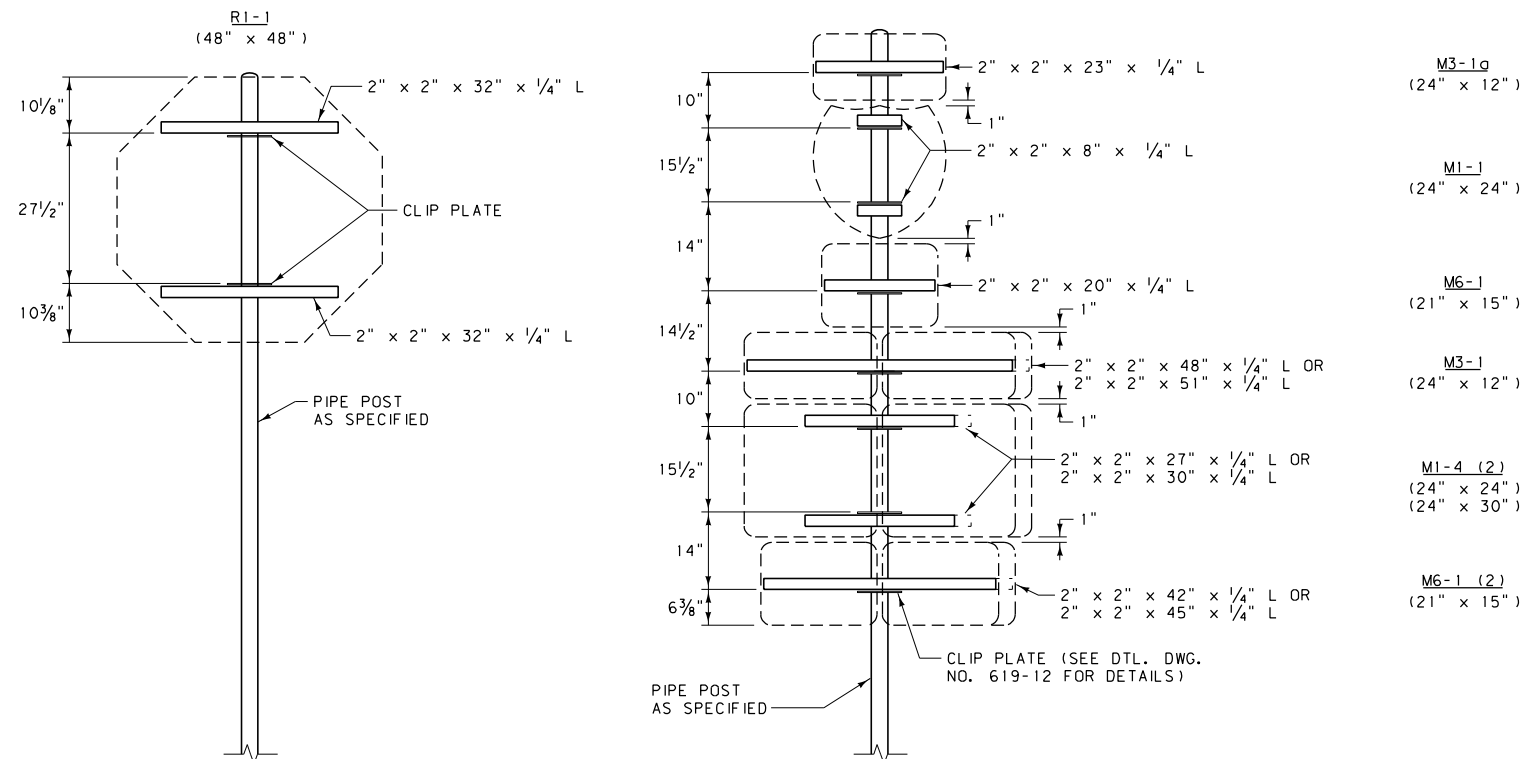

TYPICAL MOUNTING DETAILS
(FOR 3" DIA. AND LARGER PIPE)

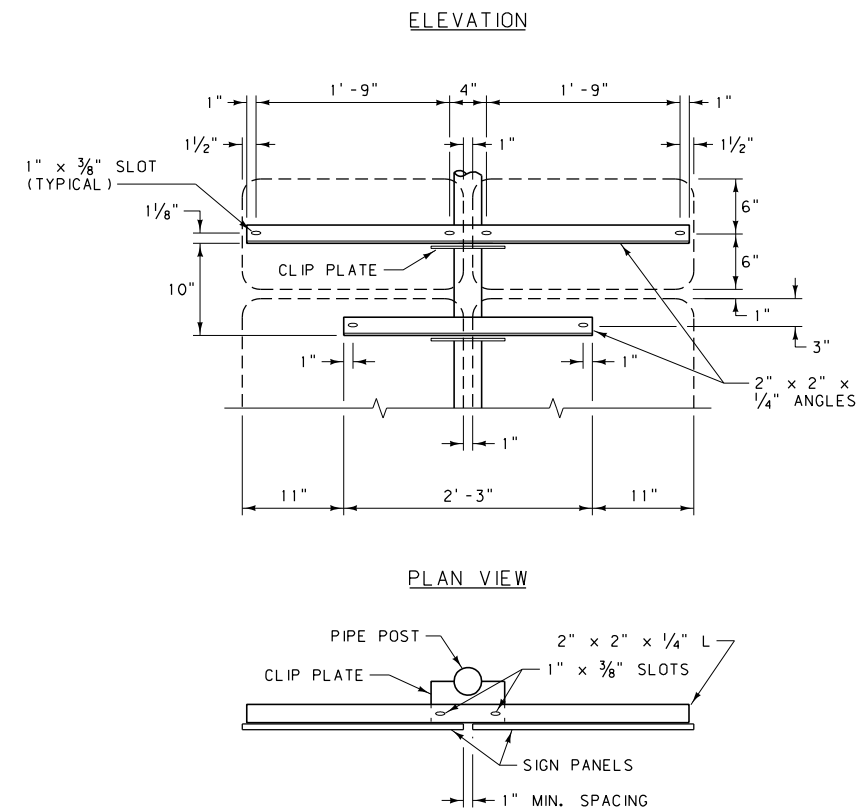

NOTES:
THE COST FOR MOUNTING D-3 SIGNS IS ABSORBED IN OTHER BID ITEMS OF THE CONTRACT.
REFER TO FHWA'S "STANDARD HIGHWAY SIGNS" FOR D-3 STREET NAME SIGN TYPICAL LAYOUT.

NOTES:
VERTICAL DIMENSIONS SHOWN ARE FROM TOP TO TOP OF ALL POST CLIP PLATES.
PLACE A SUITABLE WATERTIGHT CAP ON TOP OF ALL PIPE POSTS.
CONFORM MATERIAL USED IN FABRICATION OF POST CLIPS AND ANGLE BRACKETS TO SECTION 556 OF THE STANDARD SPECIFICATIONS.
THE LENGTH OF EACH ANGLE BRACKET DEPENDS ON THE MOUNTING ASSEMBLY AND HOLE SPACING OF EACH SIGN. THE ASSEMBLIES SHOWN ARE TYPICAL INSTALLATIONS. ERECT SIMILAR ASSEMBLIES IN A LIKE MANNER.
REFER TO FHWA'S "STANDARD HIGHWAY SIGNS" FOR STANDARD HOLE SPACING IN SIGNS.

DETAILED DRAWING	
REFERENCE	DWG. NO.
STANDARD SPEC.	619-16
SECTION 556, 619, 704	
TYPICAL STEEL POST MOUNTING DETAILS	
EFFECTIVE: FEBRUARY 2005	
MONTANA DEPARTMENT OF TRANSPORTATION <i>servicing you with pride</i>	

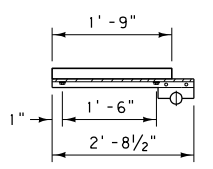
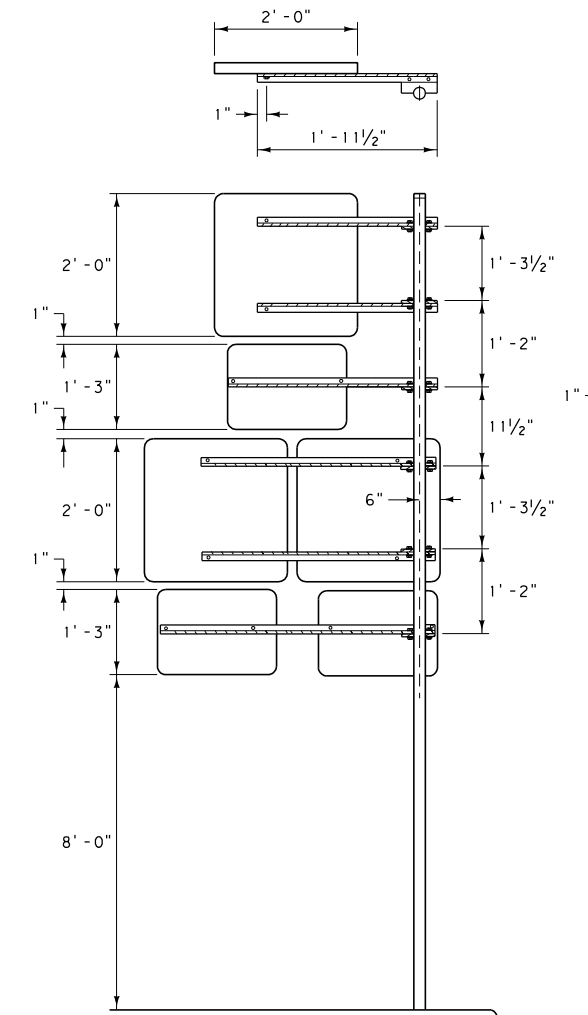
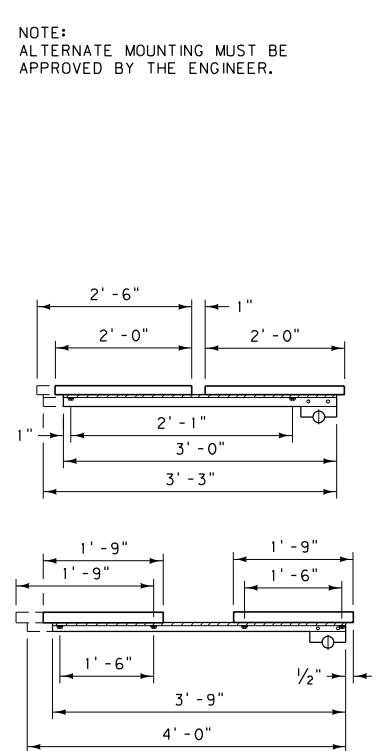
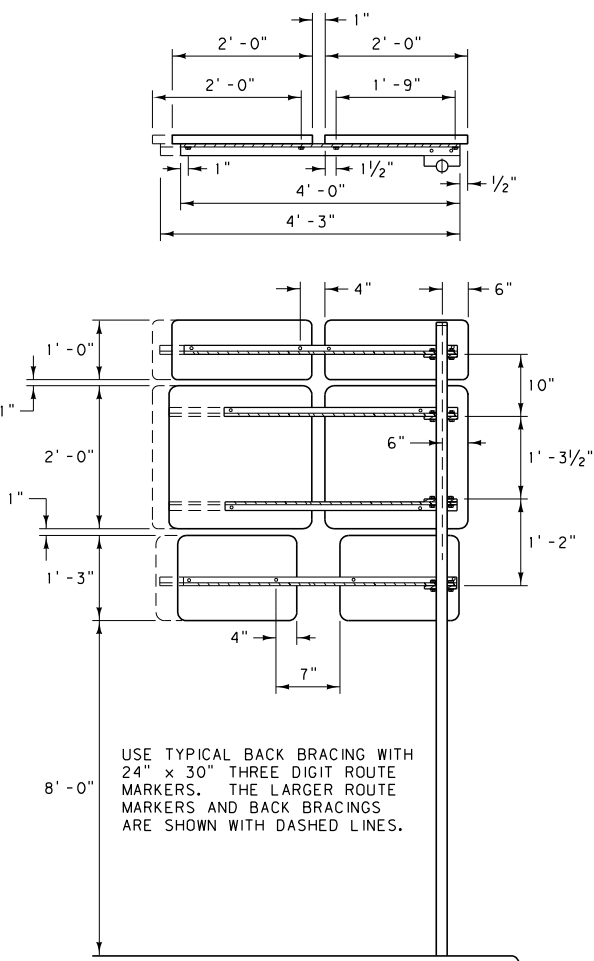
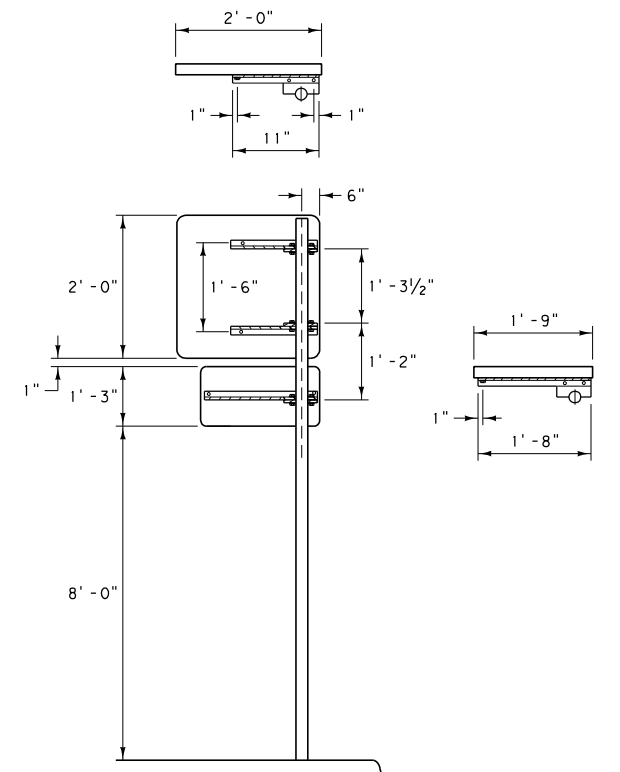
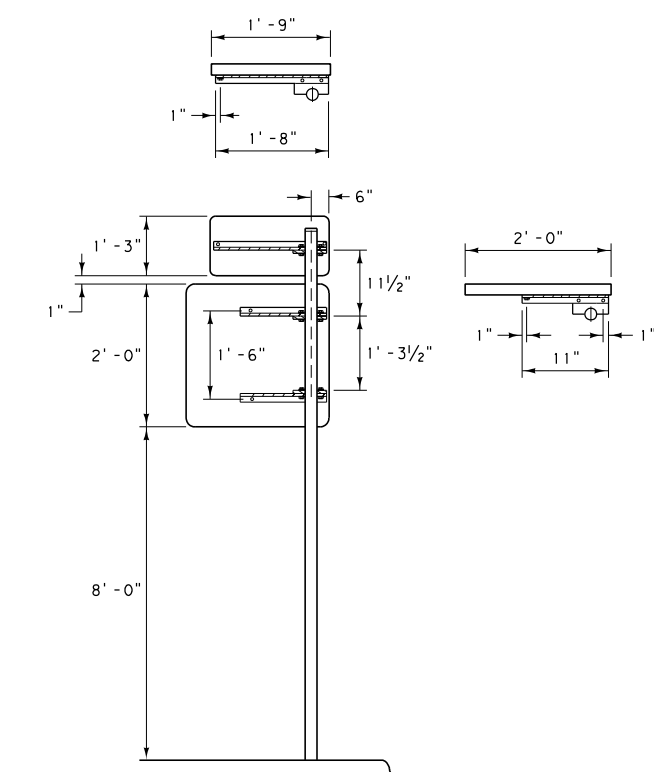
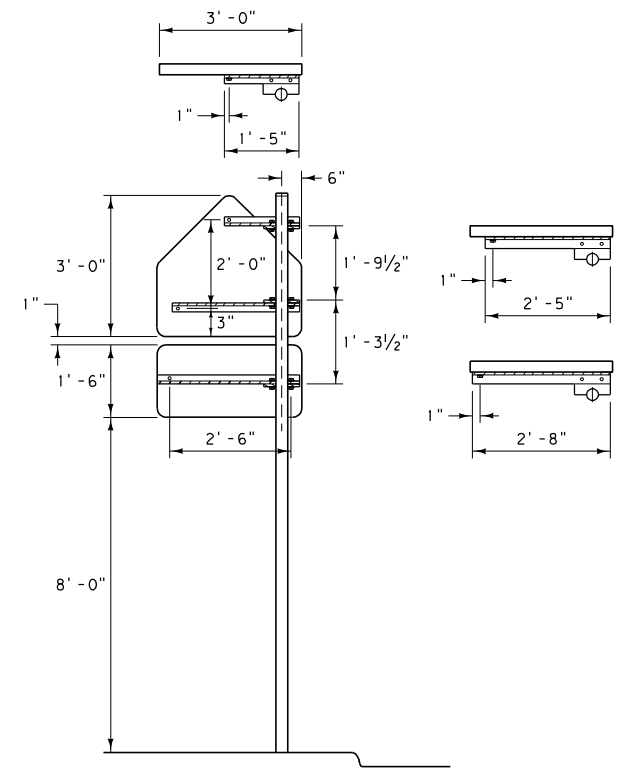
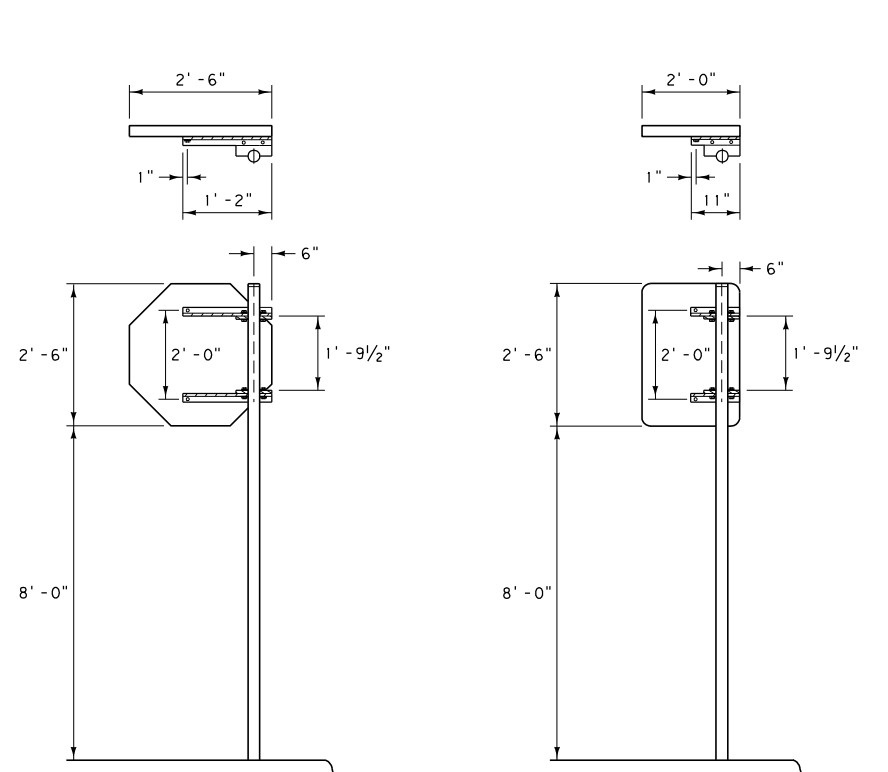

NOTE:
ALTERNATE MOUNTING MUST BE APPROVED BY THE ENGINEER.

NOTES:
REFER TO FHWA'S MANUAL "STANDARD HIGHWAY SIGNS" FOR STANDARD HOLE SPACING IN SIGNS.
USE POST CLIPS AS SHOWN IN SIGNING DETAILED DRAWING NO. 619-12 WHEN CANTILEVER MOUNTING IS NECESSARY.
USE POSTS ONE SIZE LARGER THAN THOSE REQUIRED FOR STANDARD MOUNTINGS.
DIMENSIONS FOR POST CLIP SPACING ARE SHOWN TO THE TOP OF EACH CLIP.

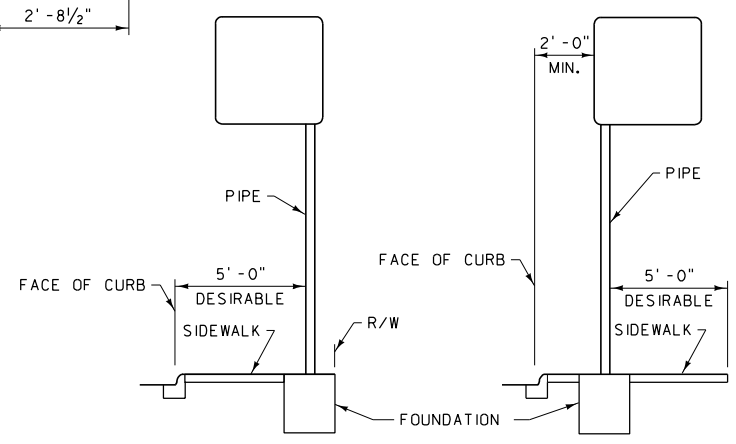
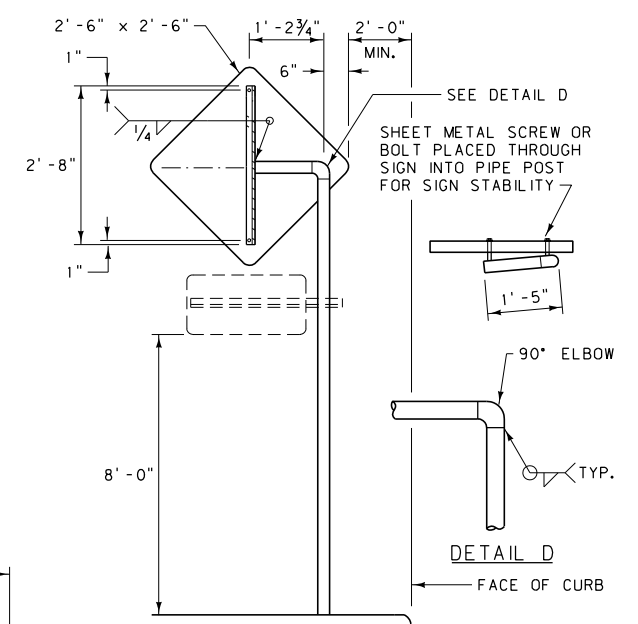

ALTERNATE A
USE THE STANDARD TYPE MOUNTING BEHIND SIDEWALKS IF R/W LIMITS PERMIT. IF R/W DOES NOT PERMIT, THEN ALTERNATE A SHOULD BE USED BEHIND SIDEWALKS OR IN THE SIDEWALK NEXT TO A BUILDING.
ALTERNATE B
IF CONDITIONS ARE SUCH THAT THE SIGN CANNOT BE MOUNTED ON THE BACKSIDE OF THE SIDEWALK THEN USE ALTERNATE B.

DETAIL C

DETAILED DRAWING	
REFERENCE	DWG. NO.
STANDARD SPEC.	619-18
SECTION 556, 619, 704	
CANTILEVER TYPE SIGN SUPPORT DETAILS FOR SIDEWALK AREAS	
EFFECTIVE: FEBRUARY 2005	
	MONTANA DEPARTMENT OF TRANSPORTATION
servicing you with pride	

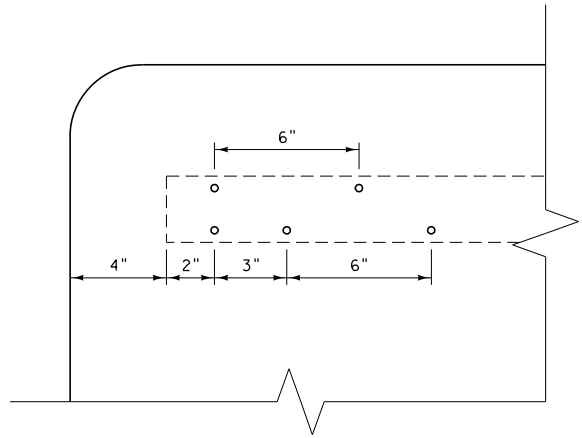
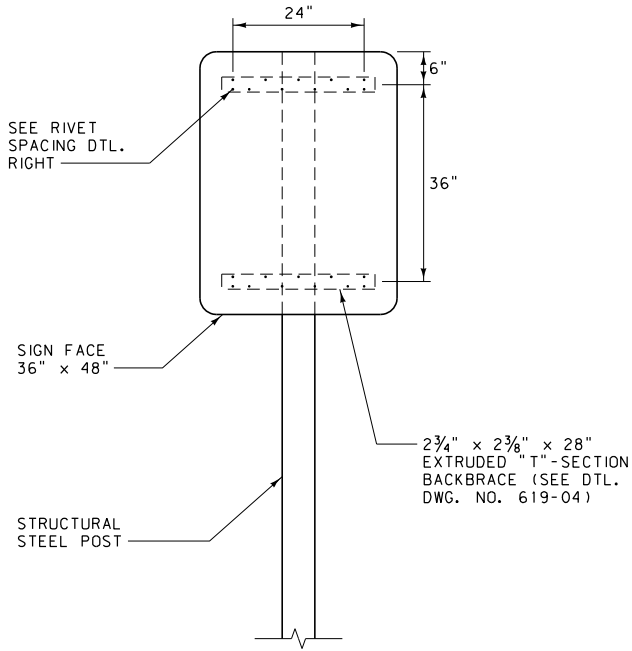

RIVET SPACING

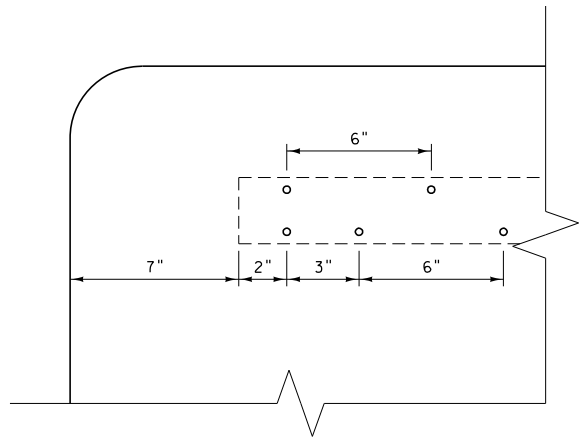
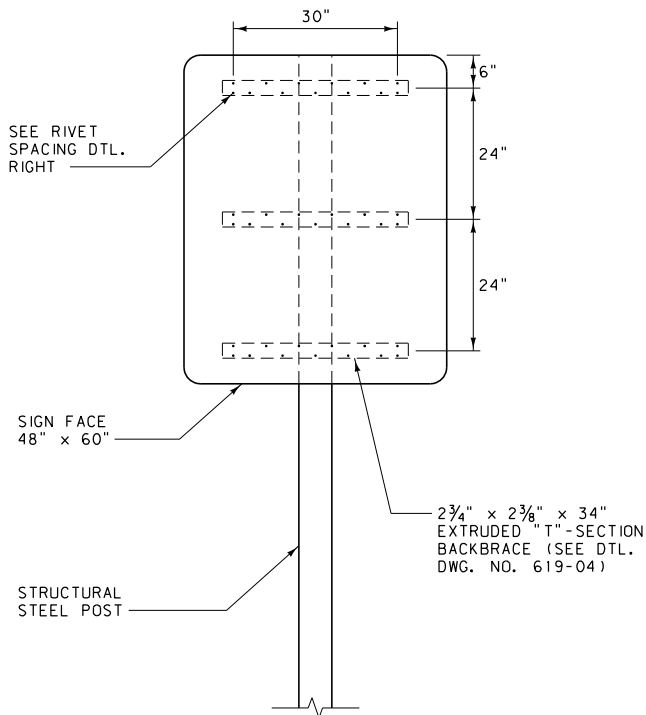

RIVET SPACING

NOTE:
SEE THE PLANS
FOR BACKBRACING
REQUIREMENTS.

DETAILED DRAWING	
REFERENCE STANDARD SPEC. SECTION 619, 704	DWG. NO. 619-19
STRUCTURAL STEEL POST SIGN MOUNTING DETAILS	
EFFECTIVE: FEBRUARY 2005	
 MONTANA DEPARTMENT OF TRANSPORTATION <i>servicing you with pride</i>	

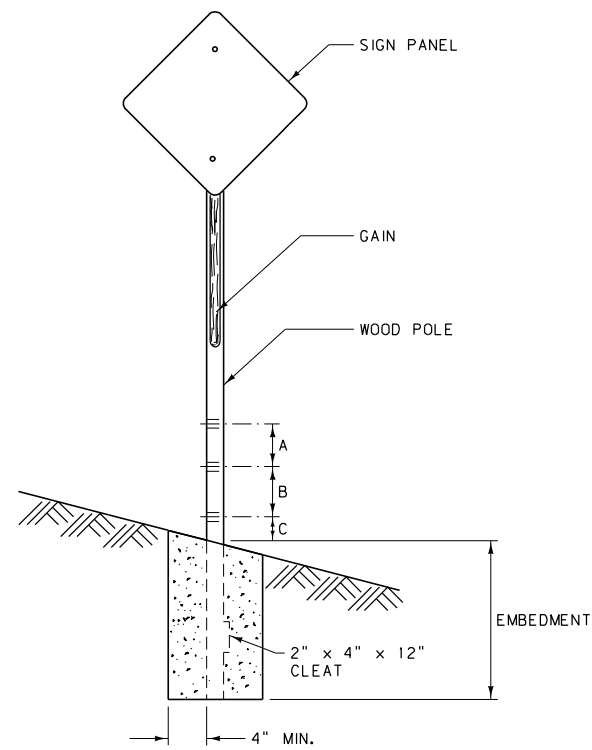

BREAKAWAY AND FOOTING DETAILS

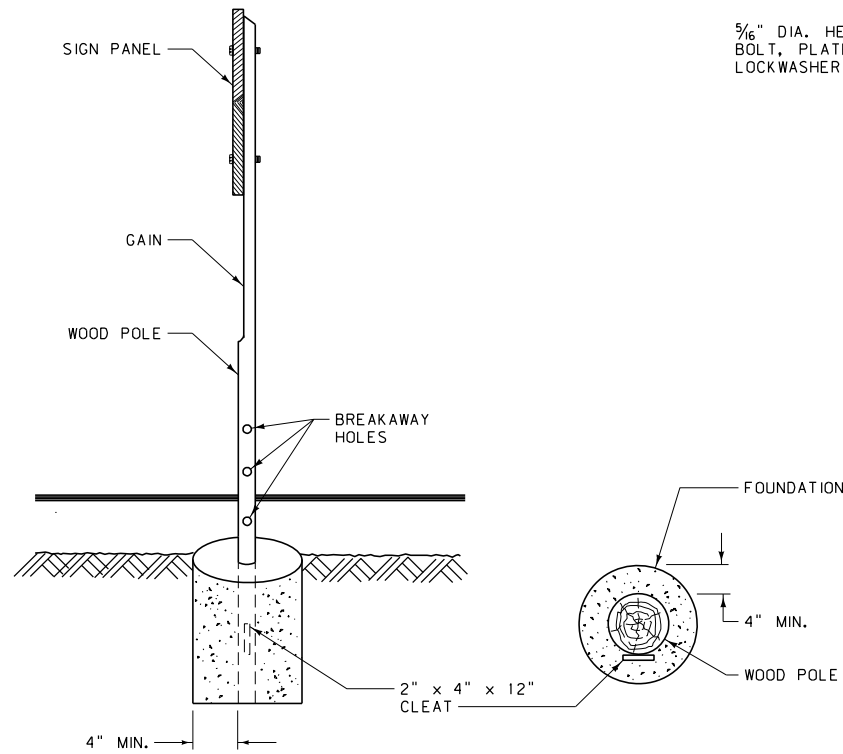

5/16" DIA. HEX HEAD BOLT, PLATE WASHER, LOCKWASHER AND NUT

5/16" DIA. HEX HEAD BOLT, PLATE WASHER, LOCKWASHER AND NUT

5/16" DIA. HEX HEAD BOLT, PLATE WASHER, LOCKWASHER AND NUT

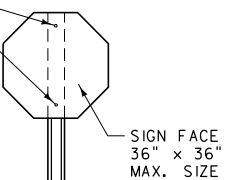

REGULATORY SIGNS

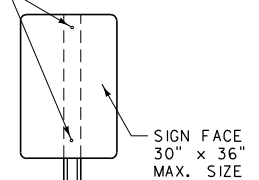

TYPICAL SIGN MOUNTINGS
(NO BACKBRACING)

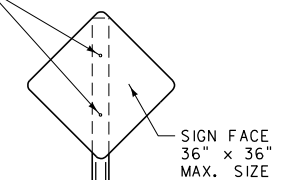

WARNING SIGNS

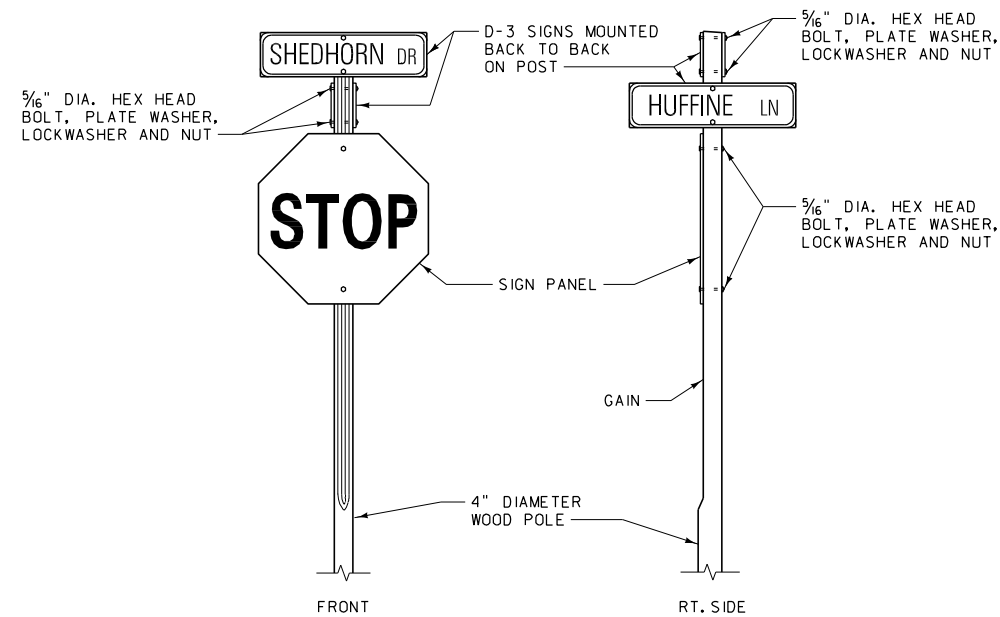

STREET NAME SIGN INSTALLATION

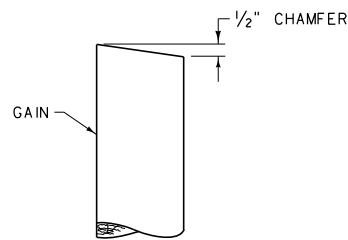

TOP END TREATMENT

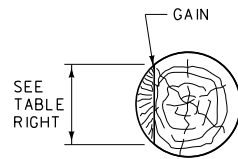

GAIN DETAIL

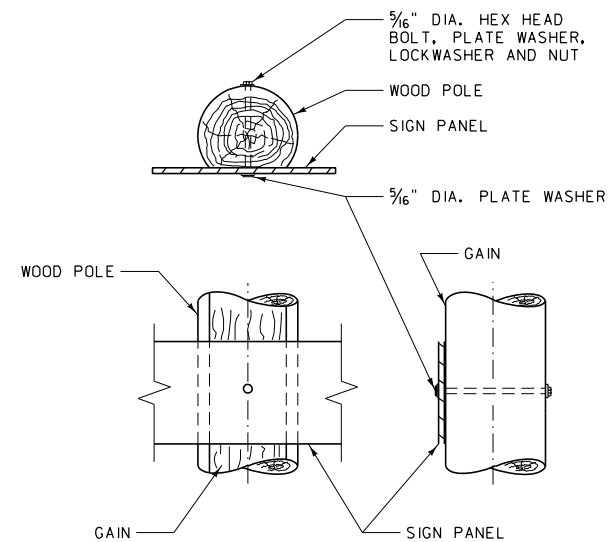

SIGN MOUNTING DETAIL

NOTES:

CONFORM ALL WOOD POLES TO THE REQUIREMENTS OF SECTION 704 OF THE STANDARD SPECIFICATIONS.

GAIN ALL POLES ON THE SIGN SIDE THE MINIMUM WIDTH SHOWN IN THE TABLE, FOR HALF THE LENGTH OF EACH POLE.

BREAKAWAY DETAILS ARE STANDARD FOR ALL WOOD POLES LISTED IN THE TABLE, ON SINGLE AND MULTIPLE SIGN SUPPORTS.

ALL BOLTS, NUTS AND WASHERS MUST CONSIST OF ALUMINUM, STAINLESS STEEL OR CADMIUM PLATED STEEL MATERIAL.

ATTACH A 2" x 4" x 12" BOARD 12" FROM THE BOTTOM OF THE POLE TO PREVENT SPINNING. ATTACH THIS CLEAT BY DRIVING TWO 16d NAILS THROUGH THE CLEAT AND INTO THE POLE. TREAT THE 2" x 4" CLEAT ACCORDING TO THE STANDARD SPECIFICATIONS.

⊗ THE MAXIMUM CROSS-SECTIONAL AREA AT A POINT 4" ABOVE GROUND LEVEL MAY NOT EXCEED 24 SQUARE INCHES EXCLUSIVE OF DRILLED BREAKAWAY HOLES FOR UNPROTECTED POST INSTALLATIONS. THE HOLE DIAMETER MAY BE ENLARGED IF NECESSARY TO INSURE THIS REQUIREMENT IS MET.

USE SOIL CEMENT FOR THE FOUNDATION - SEE SECTION 619.03.3 OF THE STANDARD SPECIFICATIONS.

FOR SIGNS REQUIRING BACKBRACING, CONSULT DTL. DWG. NO. 619-21 AND 619-22 FOR BACKBRACING OPTIONS AND DETAILS.

NOTES:

THE COST FOR MOUNTING D-3 SIGNS IS ABSORBED IN OTHER BID ITEMS OF THE CONTRACT.

REFER TO FHWA'S "STANDARD HIGHWAY SIGNS" FOR D-3 STREET NAME SIGN TYPICAL LAYOUT.

MUST BE PROTECTED OR OUT OF CLEAR ZONE

POLE SIZE	A	B	C	HOLE DIA. (SEE NOTE ⊗)	EMBEDMENT	GAIN
3" TOP DIA.	~	~	~	~	3' - 0"	2 3/4"
4" TOP DIA.	~	~	~	~	3' - 0"	3 1/2"
5" TOP DIA.	~	12"	4"	2"	3' - 6"	4"
6" TOP DIA.	~	12"	4"	2 1/2"	4' - 6"	4"
CLASS 4	~	12"	4"	2"	5' - 0"	4"
CLASS 3	~	12"	4"	2 1/2"	5' - 6"	4"
CLASS 2	6"	6"	4"	2"	6' - 0"	4"
CLASS 1	6"	6"	4"	2 1/2"	6' - 6"	4"

DETAILED DRAWING

REFERENCE DWG. NO.
STANDARD SPEC. 619-20
SECTION 619, 704

TREATED WOOD POLE
SIGN MOUNTING AND
SUPPORT DETAILS

EFFECTIVE: FEBRUARY 2005

MDT MONTANA DEPARTMENT
OF TRANSPORTATION
servicing you with pride

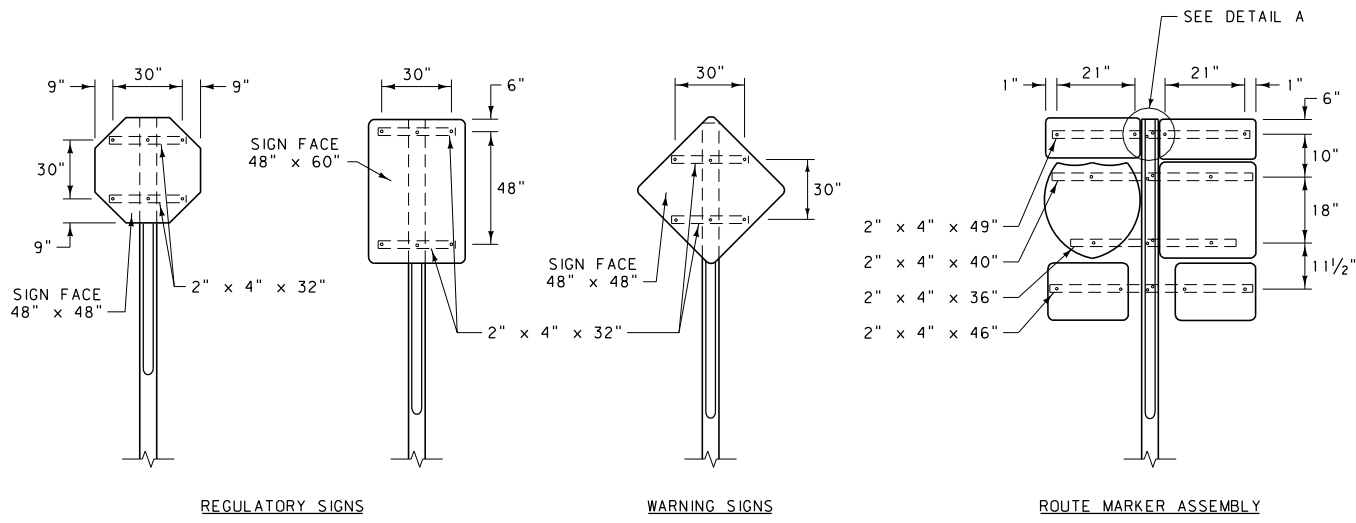

NOTE:

SIGNS OF THESE SIZES AND LARGER REQUIRE WOOD BACKBRACING.

SMALLER SIGNS MAY REQUIRE BACKBRACING IF THE CONDITIONS WARRANT (SEE SIGNING PLANS). IN THIS CASE, THE CONTRACTOR HAS THE OPTION OF USING WOOD OR STEEL BACKBRACING (SEE DTL. DWG. NO. 619-22).

WOOD BACKBRACE INSTALLATIONS

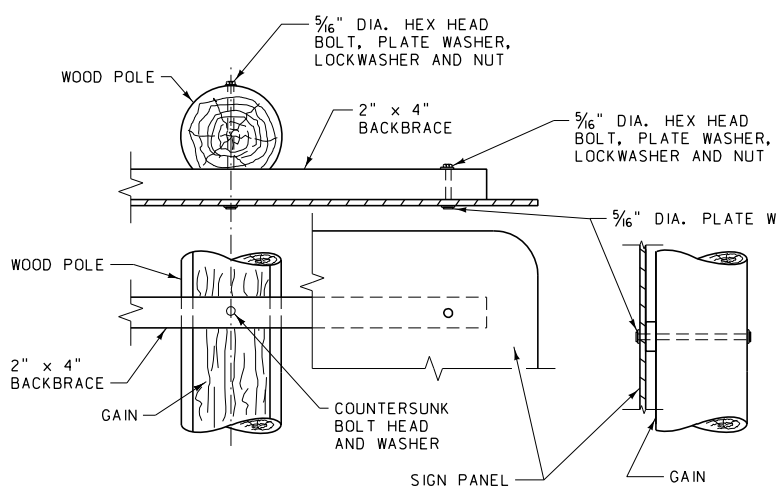

SIGN MOUNTING DETAIL

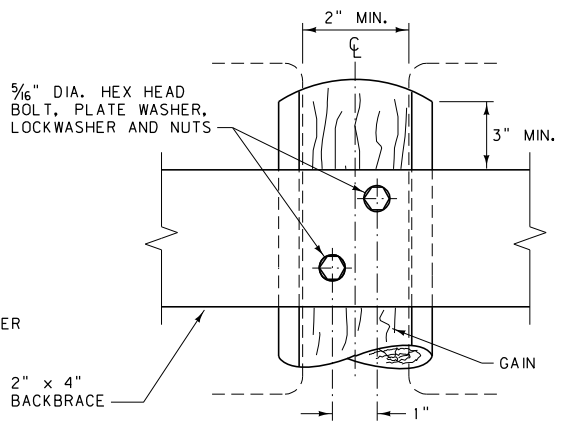

DETAIL A (BACKBRACE)

NOTES:

CONFORM ALL WOOD POLES TO THE REQUIREMENTS OF SECTION 704 OF THE STANDARD SPECIFICATIONS.

GAIN ALL POLES ON THE SIGN SIDE THE MINIMUM WIDTH SHOWN IN THE TABLE ON DTL. DWG. NO. 619-20, FOR HALF THE LENGTH OF EACH POLE.

USE 2" x 4" S4S LUMBER FOR ALL WOOD BACKBRACING, CONFORMING TO THE REQUIREMENTS OF SECTION 704 OF THE STANDARD SPECIFICATIONS.

ALL BOLTS, NUTS AND WASHERS MUST CONSIST OF ALUMINUM, STAINLESS STEEL OR CADMIUM PLATED STEEL MATERIAL.

SEE DTL. DWG. NO. 619-20 FOR BREAKAWAY AND SUPPORT DETAILS.

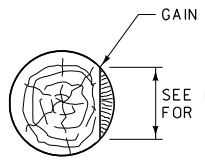

GAIN DETAIL

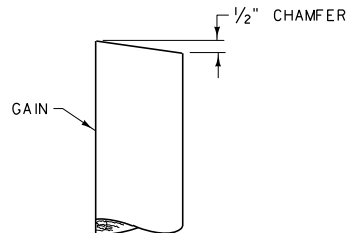

TOP END TREATMENT

DETAILED DRAWING	
REFERENCE STANDARD SPEC. SECTION 619, 704	DWG. NO. 619-21
TREATED WOOD POLE SIGN MOUNTING DETAILS	
EFFECTIVE: FEBRUARY 2005	
 MONTANA DEPARTMENT OF TRANSPORTATION <i>-serving you with pride</i>	

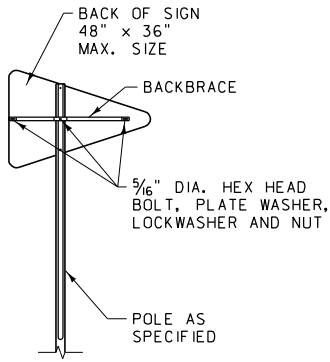

NO PASSING PENNANTS

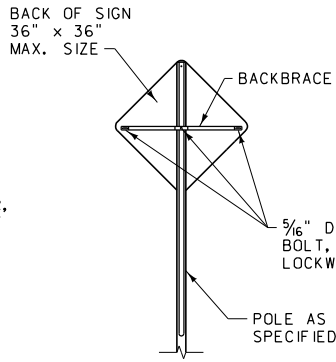

WARNING SIGNS

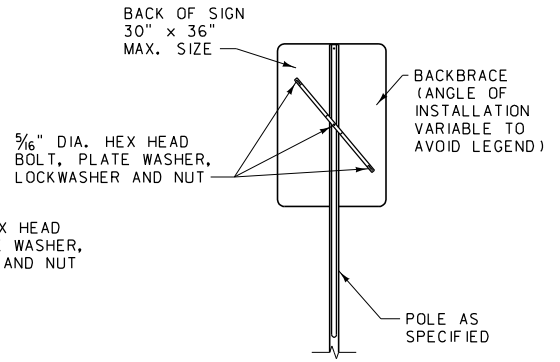

REGULATORY SIGNS

STEEL BACKBRACE INSTALLATIONS

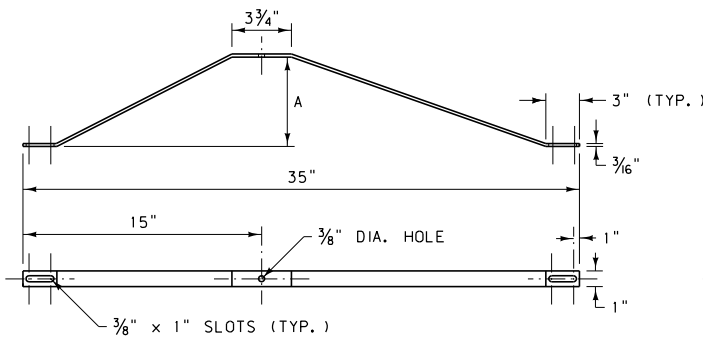

NO PASSING PENNANTS

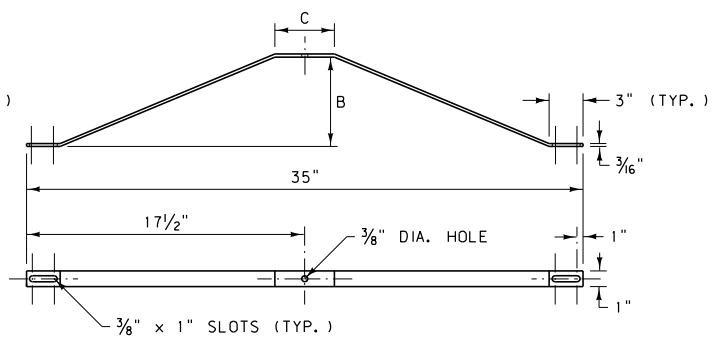

REGULATORY AND WARNING SIGNS

STEEL BACKBRACE DETAILS

POLE DIA.	A	B	C
3"	2 1/8"	2 1/8"	3 3/4"
4"	3"	3"	3 3/4"
5"	~	4"	4 1/4"
6"	~	5 1/4"	4 1/4"

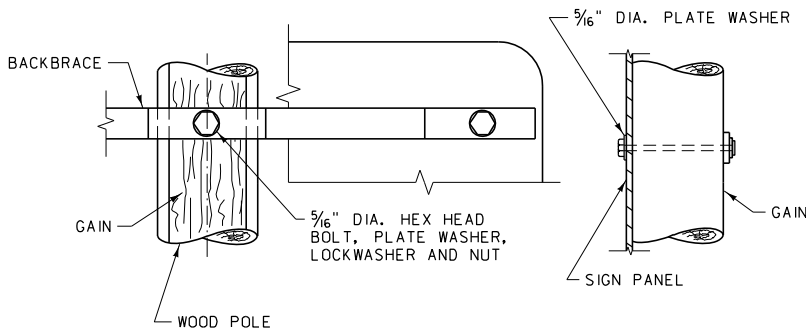
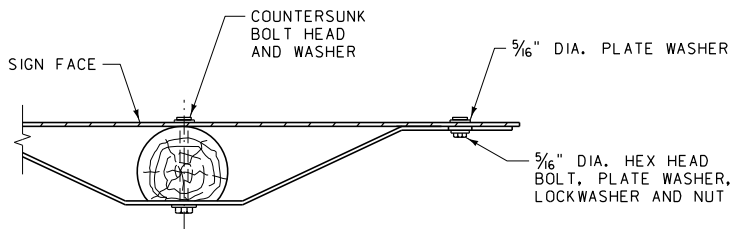

SIGN MOUNTING DETAIL

NOTES:

USE COMMERCIAL QUALITY, MILD STEEL, HOT-DIPPED AFTER FABRICATION. GALVANIZE ACCORDING TO THE SPECIFICATIONS OF AASHTO M 111.

SEE DTL. DWG. NO. 619-21 FOR APPLICATIONS OF THIS TYPE OF BRACE AND ADDITIONAL SIGN MOUNTING REQUIREMENTS.

SEE DTL. DWG. NO. 619-20 FOR BREAKAWAY AND SUPPORT DETAILS.

DETAILED DRAWING	
REFERENCE STANDARD SPEC. SECTION 619	DWG. NO. 619-22
TREATED WOOD POLE OPTIONAL BACKBRACE	
EFFECTIVE: FEBRUARY 2005	
 MONTANA DEPARTMENT OF TRANSPORTATION <i>servicing you with pride</i>	

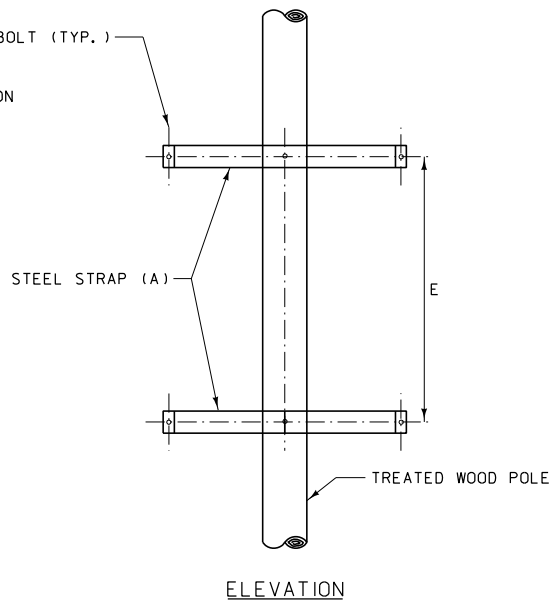
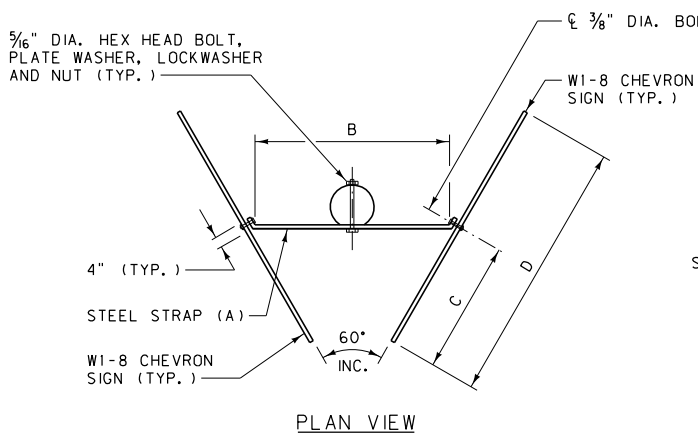

SIGN SIZE	DIMENSIONS				
	A	B	C	D	E
18" x 24"	1/4" x 2" x 1'-11"	15"	9"	18"	18"
24" x 30"	1/4" x 2" x 2'-2"	18"	12"	24"	24"
30" x 36"	1/4" x 2" x 2'-5"	21"	15"	30"	30"
36" x 48"	1/4" x 2" x 2'-8"	24"	18"	36"	36"

WOOD POST MOUNTING

MOUNT 2 CHEVRON SIGNS ON EACH POST WITH EACH PANEL ADJUSTED TO APPROXIMATE RIGHT ANGLE TO ROADWAY CENTERLINE. EXACT LOCATION AND ANGLE TO BE DETERMINED BY ENGINEER.

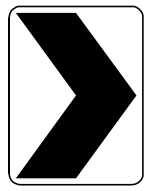

W1-8 CHEVRON ALIGNMENT SIGNS MAY BE USED AS AN ALTERNATE OR AS A SUPPLEMENT TO DELINEATION TO PROVIDE ADDITIONAL EMPHASIS AND GUIDANCE WHEN A CHANGE IN HORIZONTAL ALIGNMENT EXISTS IN THE ROADWAY.

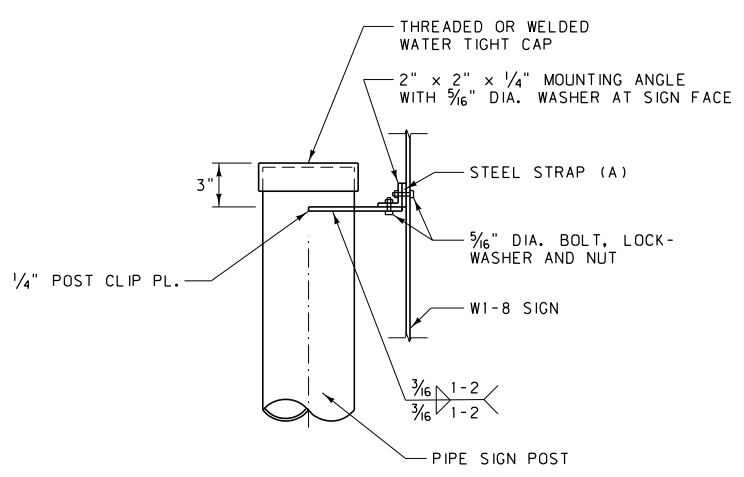

STEEL PIPE MOUNTING

NOTES:

INSTALL CHEVRONS WITH A MINIMUM 10'-0" HORIZONTAL CLEARANCE AND A 5'-0" VERTICAL MOUNTING HEIGHT.

SPACING FOR DESIGN PURPOSES IS DOUBLE THE SPACING SHOWN IN THE TABLE ON DTL. DWG. NO. 619-36, UP TO A MAXIMUM CHEVRON SPACING OF 200'. A MINIMUM OF 3 VISIBLE CHEVRONS ARE REQUIRED THROUGH A CURVE.

FIELD INSPECT THE CHEVRONS AT NIGHT AND ADJUST THEIR LOCATIONS TO ACHIEVE 500' OF VISIBILITY.

DETAILED DRAWING	
REFERENCE STANDARD SPEC. SECTION 619	DWG. NO. 619-24
CHEVRON MOUNTING DETAILS	
EFFECTIVE: FEBRUARY 2005	
 MONTANA DEPARTMENT OF TRANSPORTATION <i>servicing you with pride</i>	

PANELS
FOR USE ON ROUTE MARKER ASSEMBLIES

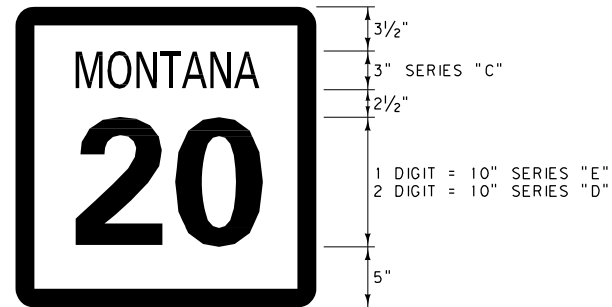

M1-5
24" x 24"
MARGIN = NONE
BORDER = 1/2"
CORNER RADIUS = 1/2"
BLACK LEGEND AND BORDER ON A RETRO-REFLECTORIZED WHITE BACKGROUND.

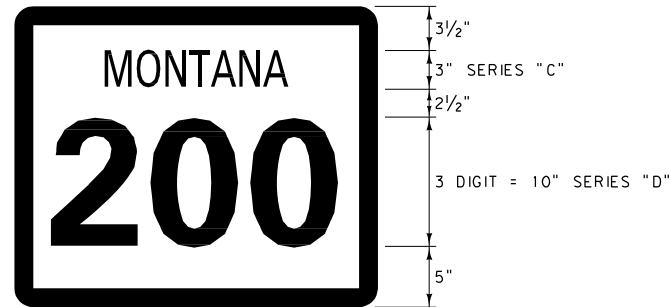

M1-5
30" x 24"
MARGIN = NONE
BORDER = 1/2"
CORNER RADIUS = 1/2"
BLACK LEGEND AND BORDER ON A RETRO-REFLECTORIZED WHITE BACKGROUND.

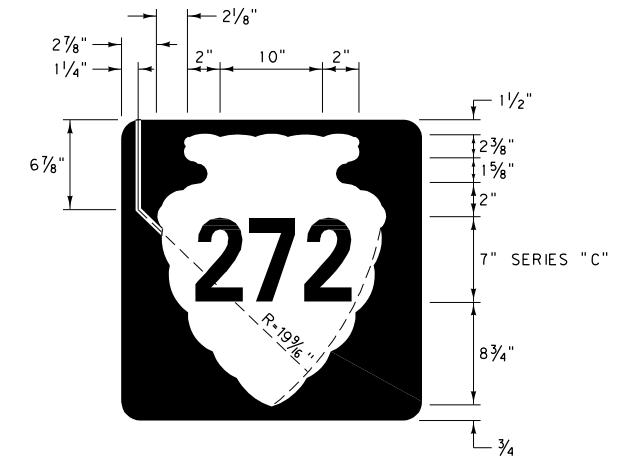

M1-10
24" x 24"
MARGIN = NONE
BORDER = SEE DESIGN ABOVE
CORNER RADIUS = 1/2"
BLACK LEGEND AND BORDER ON A RETRO-REFLECTORIZED WHITE BACKGROUND.

SHIELDS
FOR USE ON GUIDE SIGNS

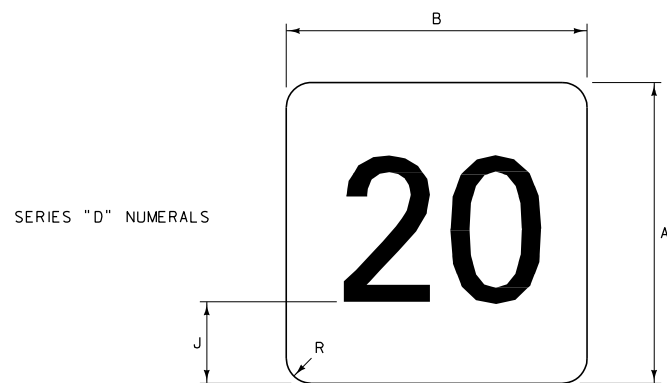

SERIES "D" NUMERALS

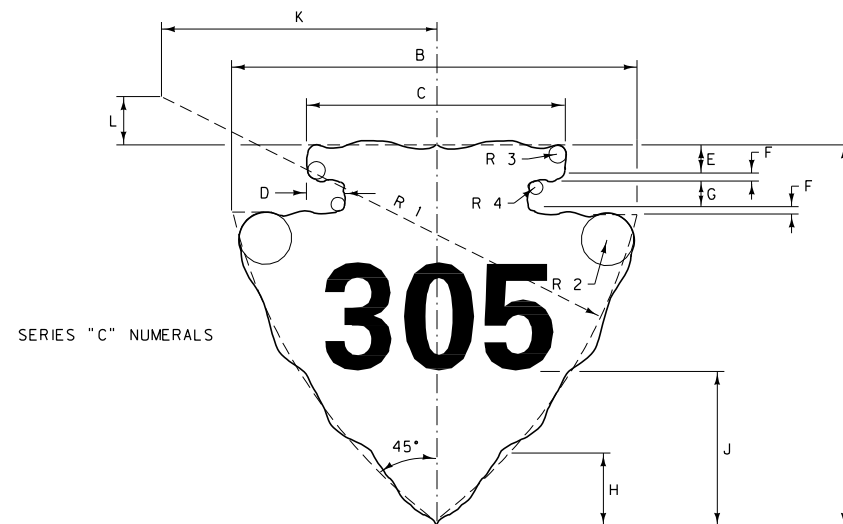

SERIES "C" NUMERALS

NOTES:
CENTER ALL NUMERALS USED ON PANELS AND SHIELDS OPTICALLY ABOUT VERTICAL CENTERLINE.
SEE SIGNS AND SIGNING MATERIALS CATALOG FOR COMPLETE LISTING OF SIGNS AND SIGN SIZES. DESIGNS ARE AVAILABLE FROM THE TRAFFIC UNIT FOR SIGNS UNIQUE TO MONTANA.

	10" NUMERALS		12" NUMERALS		18" NUMERALS	
	2 DIGIT	3 DIGIT	2 DIGIT	3 DIGIT	2 DIGIT	3 DIGIT
A	21"	21"	24"	24"	36"	36"
B	24"	30"	24"	30"	36"	45"
J	6"	6"	6 1/2"	6 1/2"	9 1/2"	9 1/2"
R	1 1/2"	1 1/2"	2"	2"	2 1/2"	2 1/2"

BLACK LEGEND ON A RETRO-REFLECTORIZED WHITE BACKGROUND WITH NO BORDER.

	A	B	C	D	E	F	G	H	J	K	L	RADII			
	R 1	R 2	R 3	R 4											
* 8" NUMERALS	26"	28"	18 1/2"	2 5/8"	3"	5/16"	2"	5 1/2"	11"	17"	2 1/4"	32"	1 3/4"	5/8"	5/16"
** 10" NUMERALS	32"	34"	22 1/2"	3 1/4"	3 5/8"	3/8"	2 1/2"	6 3/4"	13 3/4"	20 1/2"	2"	38 1/2"	2"	3/4"	3/8"
*** 12" NUMERALS	40"	42"	28"	4"	4 1/2"	1/2"	3"	8 7/16"	17"	25"	2 7/8"	48"	2 1/2"	1"	1/2"

BLACK LEGEND ON A RETRO-REFLECTORIZED WHITE BACKGROUND.

- * USE WITH STANDARD 24" U. S. SHIELD.
- ** USE WITH STANDARD 30" AND 36" U. S. SHIELD.
- *** USE WITH STANDARD 42" U. S. SHIELD AND ALL INDEPENDENT USE.

DETAILED DRAWING
REFERENCE DWG. NO. 619-26
STANDARD SPEC. SECTION 619
SPECIAL DESIGN ROUTE MARKER PANELS AND SHIELDS
EFFECTIVE: FEBRUARY 2005
MDT MONTANA DEPARTMENT OF TRANSPORTATION
serving you with pride

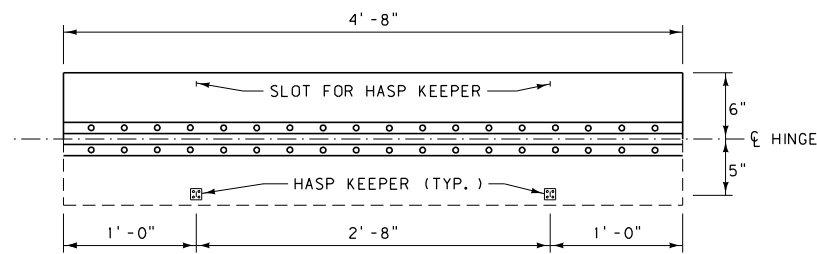
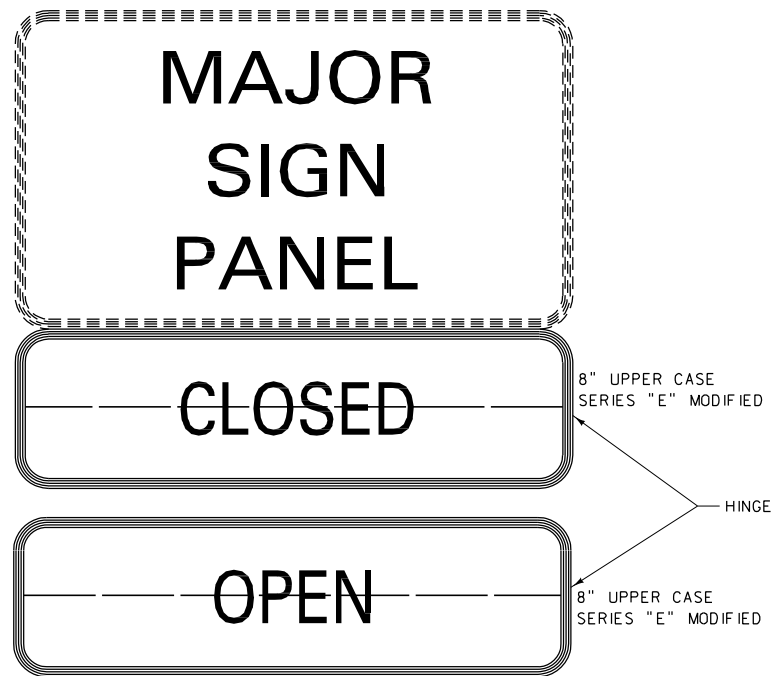

HINGE DETAIL
EXAMPLE

(5'-6" x 4'-0" D8-2A WEIGH STATION SIGN SHOWN)

ALUMINUM SHEET MOUNTING

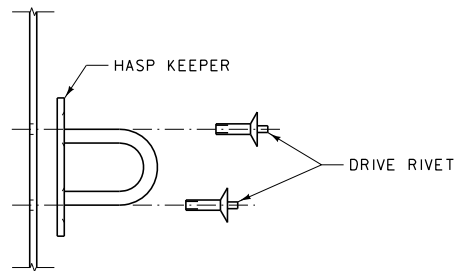

PLYWOOD MOUNTING

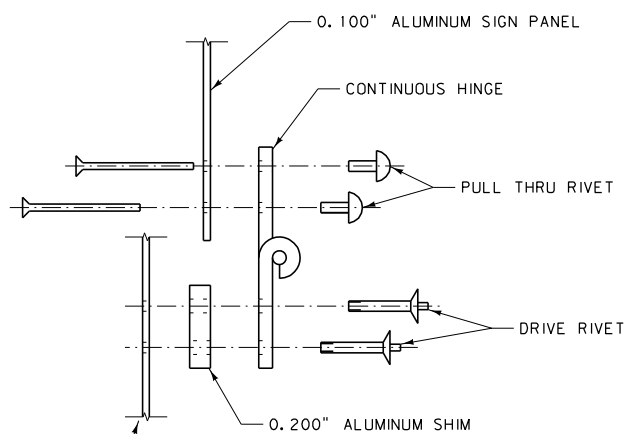
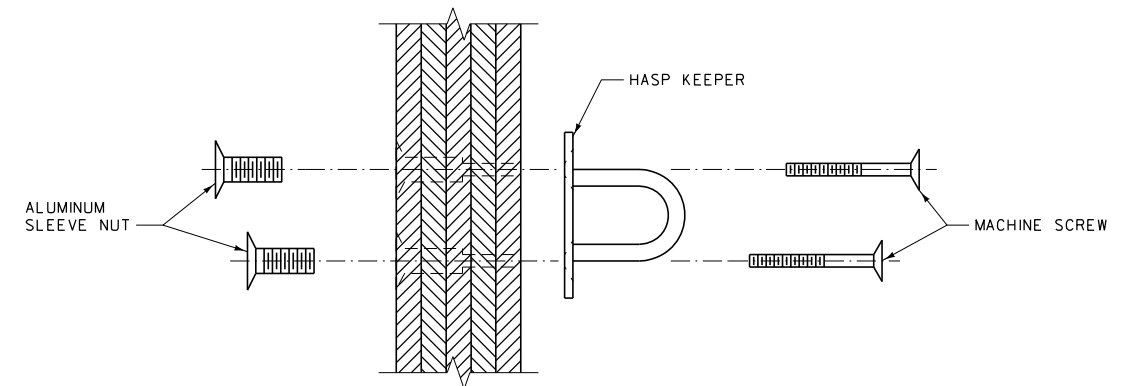

0.125" ALUMINUM SHT.
INC. SIGN PANEL

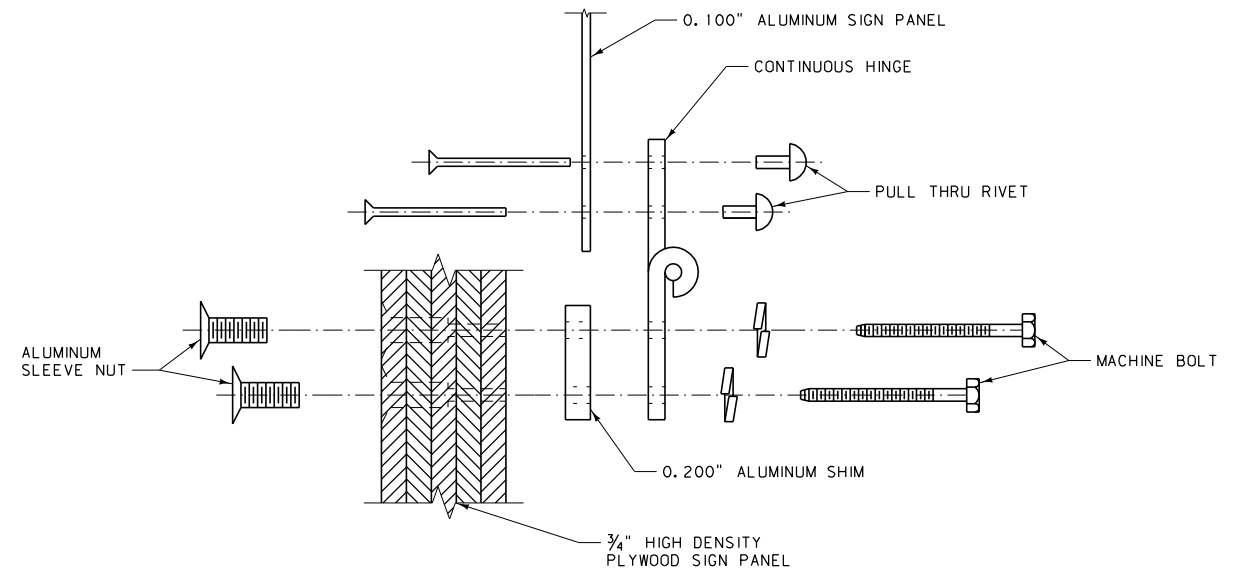

NOTES:

SEE SIGNS AND SIGNING MATERIALS CATALOG FOR COMPLETE LISTING OF SIGNS AND SIGN SIZES. DESIGNS ARE AVAILABLE FROM THE TRAFFIC UNIT FOR SIGNS UNIQUE TO MONTANA.

THE SIGN PANEL CONSISTS OF 3/4" HIGH DENSITY PLYWOOD OR 0.125" ALUMINUM SHEET INCREMENT AS SPECIFIED ON THE PLANS. THE HINGED PANEL CONSISTS OF 0.100" SHEET ALUMINUM.

PAINT ALL HARDWARE VISIBLE ON THE SIGN FACE OR COVER WITH RETRO-REFLECTIVE SHEETING, THE SAME COLOR AS THE SIGN.

SUBMIT SHOP DRAWINGS FOR APPROVAL PRIOR TO FABRICATION.

SUPPLEMENTAL SIGN PANEL BELOW MAJOR SIGN PANEL MUST HAVE RETRO-REFLECTORIZED LEGEND AND BACKGROUND MATCHING COLORS OF MAJOR PANEL.

THE MINIMUM MOUNTING HEIGHT TO THE BOTTOM OF THE SECONDARY PANEL IS 5'-0".

DETAILED DRAWING	
REFERENCE STANDARD SPEC. SECTION 619, 704	DWG. NO. 619-30
SIGN HINGE DETAILS	
EFFECTIVE: FEBRUARY 2005	
 MONTANA DEPARTMENT OF TRANSPORTATION <i>serving you with pride</i>	

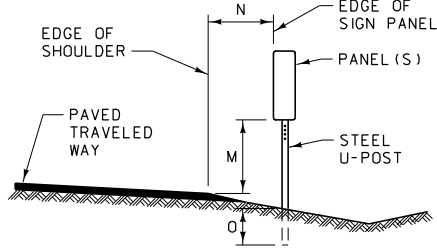
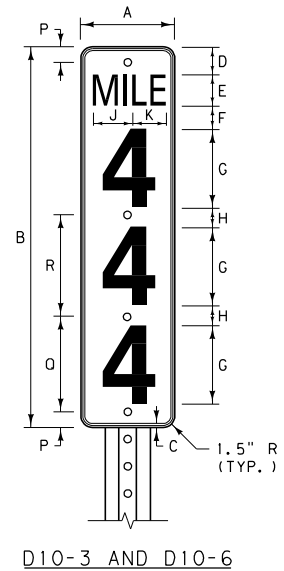
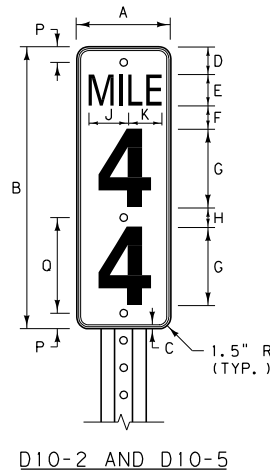
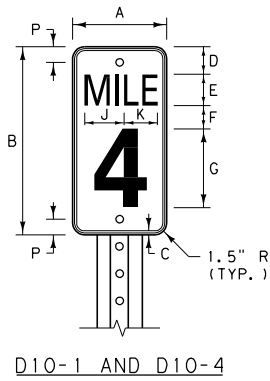

DIMENSION	INTERSTATE	NON-INTERSTATE
M	4'	4'
N	6'	2' TO 6' *
O	3' MIN.	3' MIN.

* NORMALLY IN LINE WITH DELINEATORS

TYPICAL PLACEMENT

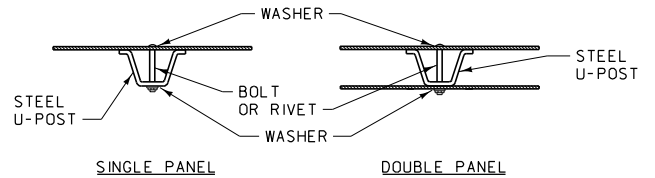

TYPICAL PANEL MOUNTING

PANEL DIMENSION INFORMATION

DIMENSION	INTERSTATE		
	D10-4 (1 DIGIT)	D10-5 (2 DIGIT)	D10-6 (3 DIGIT)
A	12.0"	12.0"	12.0"
B	24.0"	36.0"	48.0"
C	0.5"	0.5"	0.5"
D	3.5"	3.0"	3.0"
E	4.0" SERIES "C"	4.0" SERIES "C"	4.0" SERIES "C"
F	3.0"	3.0"	3.0"
G	10.0" SERIES "C"	10.0" SERIES "C"	10.0" SERIES "C"
H	~	3.0"	2.5"
J	4.6"	4.6"	4.6"
K	4.8"	4.8"	4.8"
P	2.0"	2.0"	2.0"
Q	~	13.0"	12.0"
R	~	~	13.0"

DIMENSION	NON-INTERSTATE		
	D10-1 (1 DIGIT)	D10-2 (2 DIGIT)	D10-3 (3 DIGIT)
A	10.0"	10.0"	10.0"
B	18.0"	27.0"	36.0"
C	0.5"	0.5"	0.5"
D	2.0"	2.0"	2.0"
E	4.0" SERIES "B"	4.0" SERIES "B"	4.0" SERIES "B"
F	2.0"	2.0"	2.0"
G	6.0" SERIES "C"	6.0" SERIES "C"	6.0" SERIES "C"
H	~	3.0"	3.0"
J	3.6"	3.6"	3.6"
K	3.8"	3.8"	3.8"
P	1.5"	1.5"	1.5"
Q	~	10.0"	10.0"
R	~	~	9.0"

⊗ OPTICALLY CENTER DIGITS ON VERTICAL C OF PANEL.

NOTES:

MILEPOST PANELS CONSIST OF A RETRO-REFLECTORIZED WHITE LEGEND AND BORDER ON A RETRO-REFLECTORIZED GREEN BACKGROUND.

MOUNT ALL MILEPOSTS ON STEEL U-POSTS (MIN. 2 LB./FT.) EXCEPT THE D10-6, WHICH IS MOUNTED ON A STEEL U-POST (MIN. 3 LB./FT.) AS NOTED IN THE SIGNING PLANS.

USE GALVANIZED OR CADMIUM PLATED 5/16" DIA. BOLT, NUT AND WASHER, AND JAM THREADS AFTER TIGHTENING. USE 5/16" DIA. ALUMINUM OR CADMIUM PLATED BOLT RIVETS OR PAINT RIVET HEADS WITH BRILLIANT GREEN SIGN ENAMEL.

DO NOT RELOCATE OR MOVE A MILEPOST ONCE IT HAS BEEN PROPERLY PLACED.

DETAILED DRAWING	
REFERENCE STANDARD SPEC. SECTION 619	DWG. NO. 619-32
MILEPOST DETAILS	

EFFECTIVE: APRIL 2006

DESIGN A USAGE:

USE FOR CONTINUOUS DELINEATION AND RT. SHOULDER OF ALL ROUTES.

DESIGN H USAGE:

USE ON LT. SHOULDER OF INTERSTATE ROUTES.

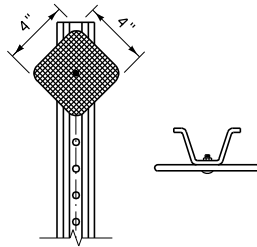

DESIGN A (WHITE)
DESIGN H (YELLOW)

DESIGN B USAGE:

USE ON LT. SHOULDER OF INTERSTATE RAMPS.

DESIGN G USAGE:

USE ON RT. SHOULDER OF INTERSTATE RAMPS.

DESIGN J USAGE:

USE FOR TRUCK ESCAPE RAMPS ONLY.

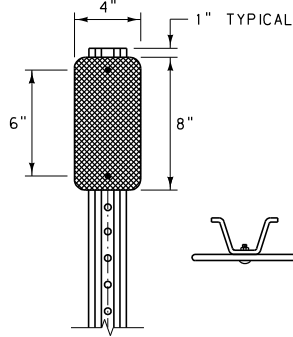

DESIGN B (YELLOW)
DESIGN G (WHITE)
DESIGN J (RED)

DESIGN C USAGE:

USE FOR CURVES WITH RADIUS 573' OR LESS, BOTH OUTSIDE AND INSIDE OF CURVE.

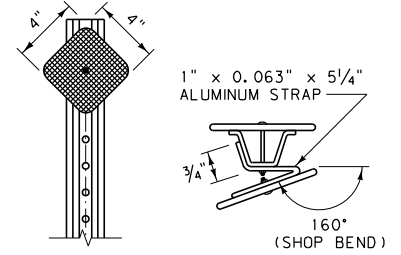

DESIGN C (WHITE)

DESIGN D USAGE:

NON-INTERSTATE ROUTES:
USE AT APPROACHES WITH STOP OR YIELD SIGNS.
INTERSTATE ROUTES:
USE FOR RAMP TERMINATION AT CROSS ROAD.

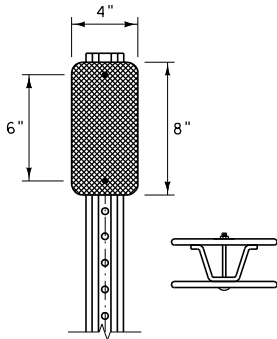

DESIGN D (YELLOW)

DESIGN E USAGE:

SPECIAL USE ONLY, FORMERLY USED AT GORES AND ISLAND NOSES.

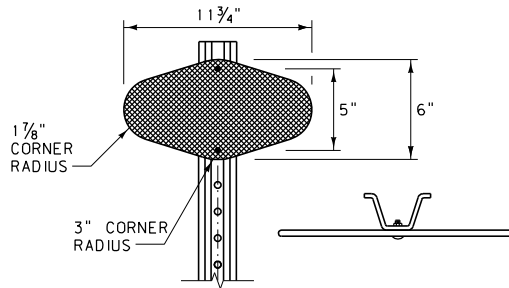

DESIGN E (YELLOW)

DESIGN F USAGE:

USE FOR CURVES WITH RADIUS GREATER THAN 573';
1433' TO 765' RADIUS:
OUTSIDE ONLY
764' TO 573' RADIUS:
OUTSIDE AND INSIDE OF CURVE

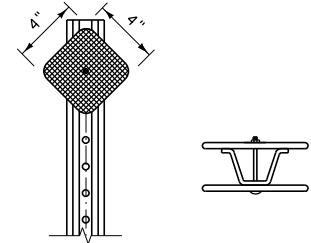

DESIGN F (WHITE)

DELINEATOR LEGEND	
DESIGN "A"	—
DESIGN "B"	— —
DESIGN "C"	↖↗
DESIGN "D"	—
DESIGN "E"	—
DESIGN "F"	—
DESIGN "G"	—<
DESIGN "H"	—>
DESIGN "J"	—x

NOTE:
SOME TYPICAL USES ARE SHOWN FOR EACH DESIGN. REFER TO THE MUTCD FOR SPECIFIC GUIDANCE.

DETAILED DRAWING	
REFERENCE STANDARD SPEC. SECTION 619	DWG. NO. 619-34

DELINEATOR DETAILS

-- REVISED --
January 2008

EFFECTIVE: APRIL 2006

MONTANA DEPARTMENT OF TRANSPORTATION

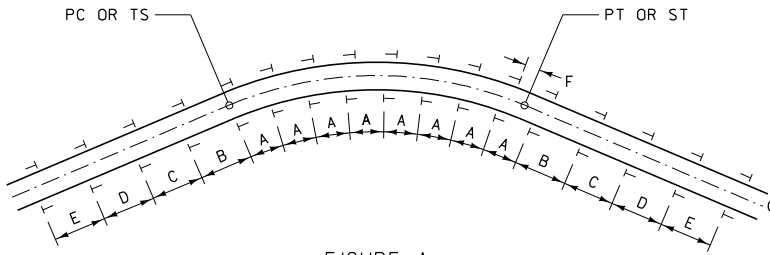

FIGURE A
SEE TABLE BELOW FOR SPACING VALUES

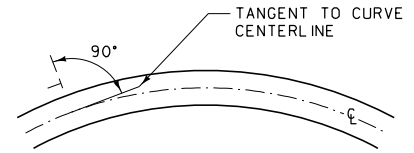

FIGURE B

HORIZONTAL CURVE SPACING TABLE					
RADIUS	SPACING ON CURVE	SPACING ON BOTH APPROACH TANGENTS			
	A	B	C	D	E
5730' & UP	300'	400'	400'	400'	400'
2865' - 5729'	225'	400'	400'	400'	400'
1910' - 2864'	160'	320'	400'	400'	400'
1433' - 1909'	130'	260'	400'	400'	400'
955' - 1432'	110'	220'	330'	400'	400'
716' - 954'	90'	185'	275'	400'	400'
478' - 715'	75'	150'	230'	300'	400'
287' - 477'	60'	125'	185'	300'	400'
0' - 286'	45'	90'	140'	275'	400'

NOTES:

FURNISH RETRO-REFLECTIVE SHEETING ACCORDING TO THE STANDARD SPECIFICATIONS FOR RETRO-REFLECTIVE SHEETING B (HIGH INTENSITY). POSITION DELINEATOR FACES PERPENDICULAR TO THE TANGENT TO CURVE CENTERLINE AS SHOWN IN FIGURE B.

MOUNT DELINEATORS ON METAL U-POSTS (1.12 LB./FT. MIN. AND 2 LB./FT. MAX.) WITH 3/16" DIA. CADMIUM PLATED BOLT(S). DRILL OR PUNCH A MINIMUM OF TWELVE 3/8" MAXIMUM DIAMETER HOLES ON 1 INCH CENTERS FROM THE TOP OF THE POST. 1/4" SQUARE HOLES MAY BE USED. IF SQUARE HOLES ARE USED, USE A LARGE HEADED BOLT OR AN APPROPRIATE WASHER. JAM THREADS AFTER TIGHTENING THE NUT TO PREVENT REMOVAL.

PLACE DELINEATORS AT A CONSTANT CLEARANCE DISTANCE FROM THE EDGE OF THE PAVEMENT EXCEPT WHERE GUARDRAIL OR OTHER OBSTRUCTIONS INTERFERE. ALIGN THE DELINEATORS WITH THE INSIDE EDGE OF THE OBSTRUCTION. CLEARANCE FOR DELINEATORS IS 6'-0" ON INTERSTATE HIGHWAYS, 2'-0" TO 6'-0" ON PRIMARY AND SECONDARY HIGHWAYS OR AS DETERMINED BY THE ENGINEER. THE STANDARD MOUNTING HEIGHT IS 4'-0" TO THE TOP OF THE POST. SUPPLY POST LENGTHS TO MAINTAIN THE PROPER MOUNTING HEIGHT AND A MINIMUM OF 18" EMBEDMENT.

SPACE DELINEATORS ACCORDING TO THE DISTANCES FOUND IN THE TABLE ABOVE OR AS SPECIFIED IN THE PLANS. IN FIGURE A, IF "F" IS GREATER THAN 20' ADD ONE REGULAR DELINEATOR IN AT "A" SPACING. UNDER NORMAL SPACING, SHOULD A DELINEATOR FALL WITHIN A CROSSROAD OR APPROACH, IT MAY BE MOVED IN EITHER DIRECTION A DISTANCE NOT TO EXCEED ONE QUARTER OF THE NORMAL SPACING. ELIMINATE DELINEATORS STILL FALLING IN SUCH AREAS.

ALL DELINEATOR REFLECTORS HAVE 3/4" CORNER RADIUS EXCEPT DESIGN "E".

MOUNT THE DELINEATOR REFLECTOR 1" BELOW THE TOP OF THE METAL U-POST.

WHEN THE ROADWAY ADT IS LESS THAN 900, DELINEATE ALL CURVES WITH 1433' RADIUS OR LESS.

CONTINUOUSLY DELINEATE ROADWAYS WHEN THE ADT IS 900 AND GREATER, OR BY ENGINEERING JUDGEMENT.

DETAILED DRAWING	
REFERENCE STANDARD SPEC. SECTION 619, 704	DWG. NO. 619-36
DELINEATOR PLACEMENT DETAILS	

-- REVISED --
January 2008

EFFECTIVE: APRIL 2006
 MONTANA DEPARTMENT OF TRANSPORTATION
servicing you with pride

TYPE 1
X3-2

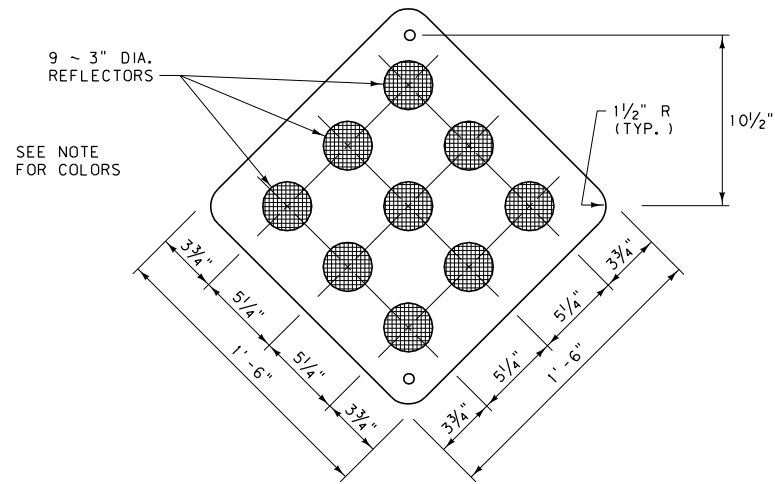

SEE NOTE FOR COLORS

NOTE:
TYPE 1 OBJECT MARKERS HAVE YELLOW REFLECTORS ON A YELLOW OR BLACK BACKGROUND OR AN ALL YELLOW RETRO-REFLECTORIZED PANEL OF THE SAME SIZE. IF USED AS END OF ROAD MARKERS, TYPE 1 MARKERS ARE RETRO-REFLECTORIZED RED OR HAVE RED REFLECTORS ON A RED OR BLACK BACKGROUND.

TYPE 2
X3-3

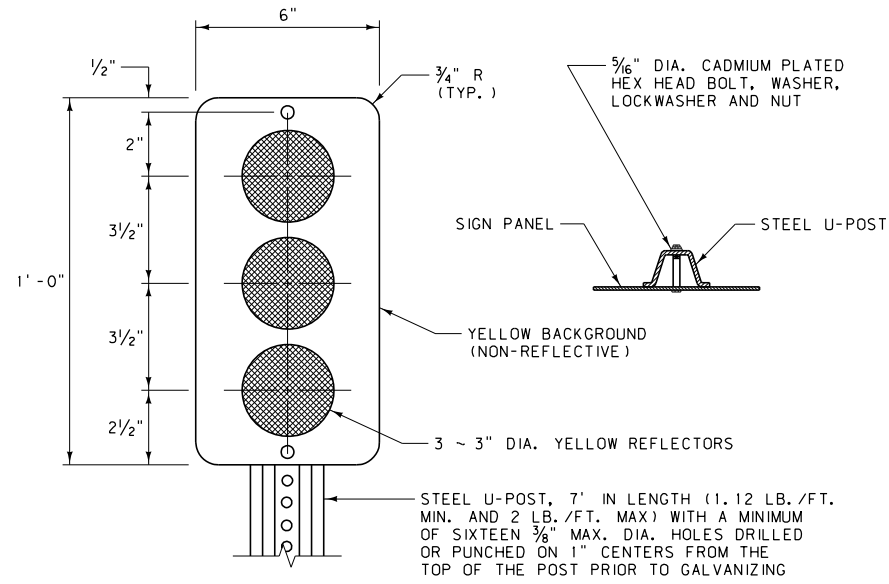

ALTERNATE DESIGN FOR TYPE 2 OBJECT MARKERS IS A YELLOW RETRO-REFLECTORIZED PANEL OF THE SAME SIZE.

TWO X3-3 PANELS MOUNTED BACK TO BACK ON STEEL U-POST

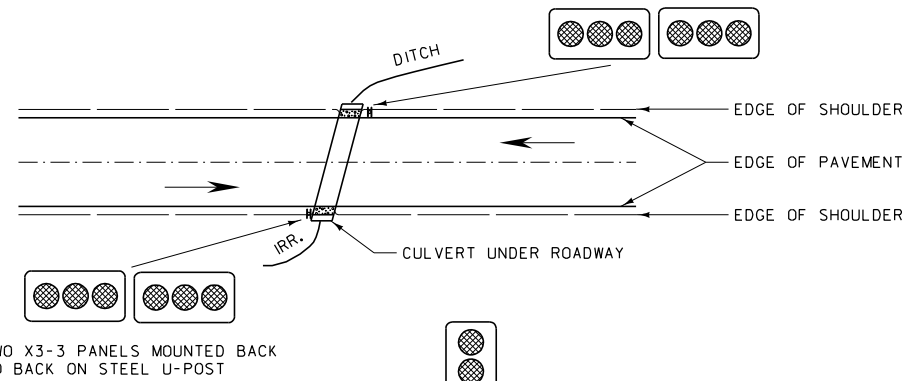

TWO X3-3 PANELS MOUNTED BACK TO BACK ON STEEL U-POST

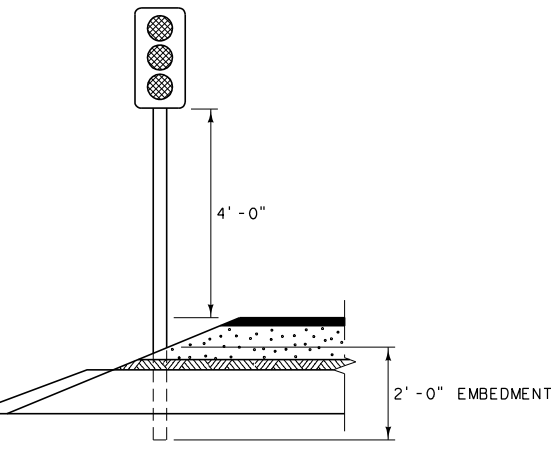

PLACE POST AND PANEL(S) SO THAT PANEL(S) ARE DIRECTLY ADJACENT TO INNER-MOST EDGE OF OBJECT NEAREST TRAVELED WAY.

TYPICAL USE AND PLACEMENT

TYPE 3
OM-3
(OM-3L SHOWN)

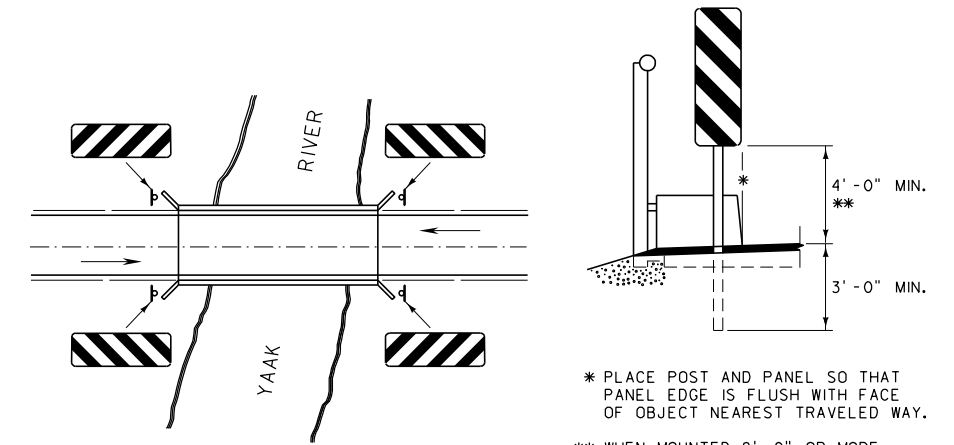
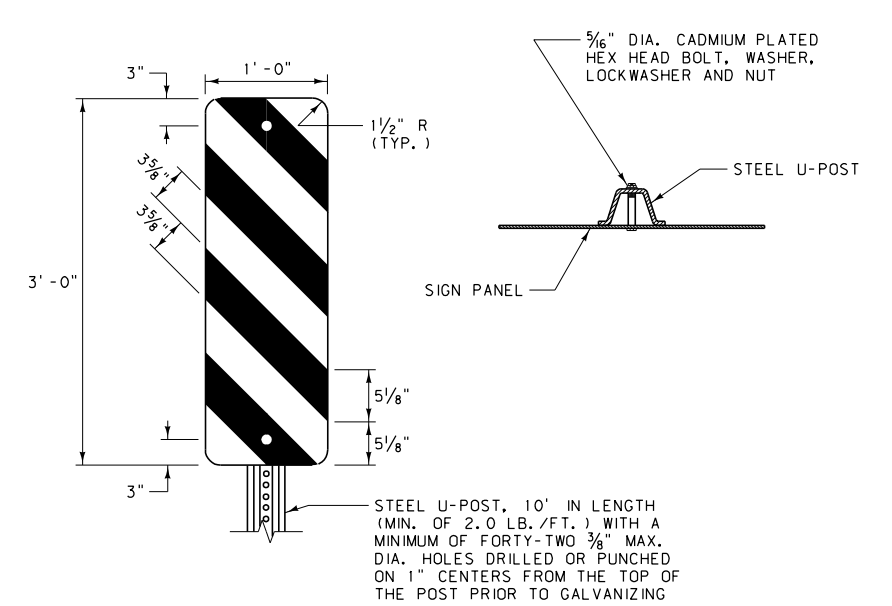



* PLACE POST AND PANEL SO THAT PANEL EDGE IS FLUSH WITH FACE OF OBJECT NEAREST TRAVELED WAY.
** WHEN MOUNTED 8'-0" OR MORE FROM CURB OR SHOULDER, THE MOUNTING HEIGHT IS MEASURED FROM THE GROUND LINE INSTEAD OF THE EDGE OF PAVEMENT.

TYPICAL USE AND PLACEMENT

TYPICAL USE AND PLACEMENT

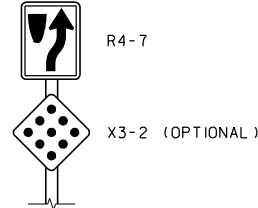
PLACEMENT OF X3-2 IS USED ONLY AS OPTIONAL TO ENHANCE TARGET VALUE WHEN NEEDED.



DETAILED DRAWING	
REFERENCE STANDARD SPEC. SECTION 619	DWG. NO. 619-38
OBJECT MARKER DESIGN AND PLACEMENT DETAILS FOR OBSTRUCTIONS ADJACENT TO OR WITHIN HIGHWAYS	
EFFECTIVE: APRIL 2006	
 MONTANA DEPARTMENT OF TRANSPORTATION <i>-serving you with pride</i>	

ANCHOR BARB (FOR PERMANENT ANCHORING OF FLEXIBLE DRIVEABLE DELINEATORS IN LOOSE, SANDY OR MARSHY SOIL)

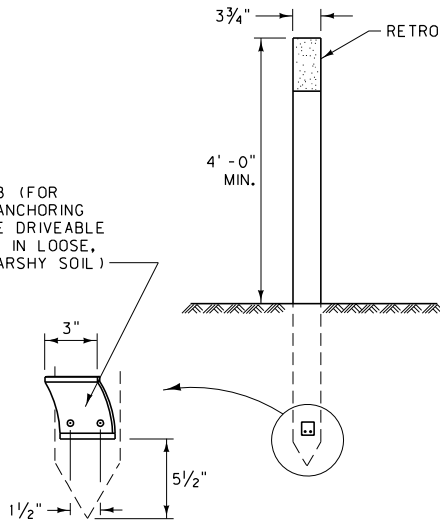

FLEXIBLE DRIVEABLE DELINEATORS

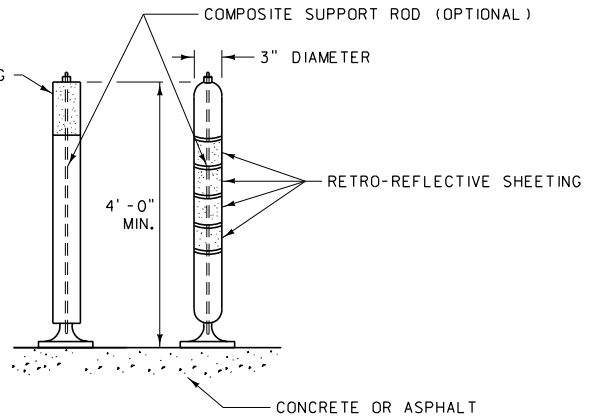

DETAILS ARE REPRESENTATIVE ONLY. ACTUAL DESIGN USED/SPECIFIED MAY VARY (SEE PLANS).

FLEXIBLE SURFACE-MOUNTED DELINEATORS

NOTES:

USE FLEXIBLE DELINEATORS SIMILAR TO THE DESIGN AND SPECIFICATIONS SHOWN ON THIS SHEET OR IN THE SIGNING PLANS OF THE CONTRACT.

MOUNT OR EMBED FLEXIBLE DELINEATORS TO THE MANUFACTURER'S SPECIFICATIONS.

RETRO-REFLECTORIZE FLEXIBLE DELINEATORS, IF REQUIRED IN PLAN SPECIFICATIONS, BY THE ADDITION OF DELINEATOR CRYSTALS, EITHER 1 1/2" x 7" OR 3" DIAMETER, OR BY ADDING TWO 3" MINIMUM WIDTH BANDS OF RETRO-REFLECTIVE SHEETING TYPE HI, 360° AROUND THE TOP OF THE DELINEATOR. USE THE COLOR OF THE DELINEATOR CRYSTALS OR RETRO-REFLECTORIZED MATERIAL AS SHOWN IN THE SIGNING PLANS OF THE CONTRACT OR THE MUTCD.

THE EXACT LOCATION AND PLACEMENT OF THE FLEXIBLE DELINEATORS ARE SHOWN IN THE SIGNING PLANS.

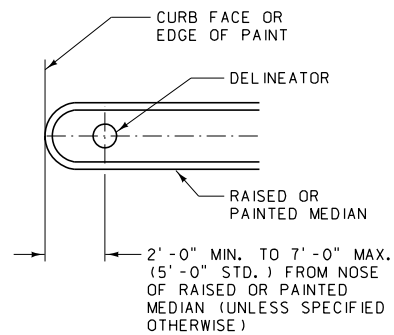

TYPICAL USE AND PLACEMENT

DETAILED DRAWING	
REFERENCE STANDARD SPEC. SECTION 619	DWG. NO. 619-40

FLEXIBLE DELINEATORS

EFFECTIVE: FEBRUARY 2005

BI BARRICADE
B (I)-L SHOWN

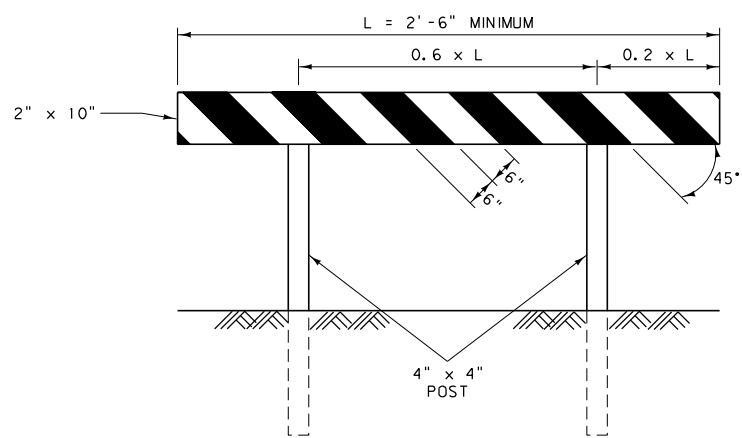

FRONT VIEW

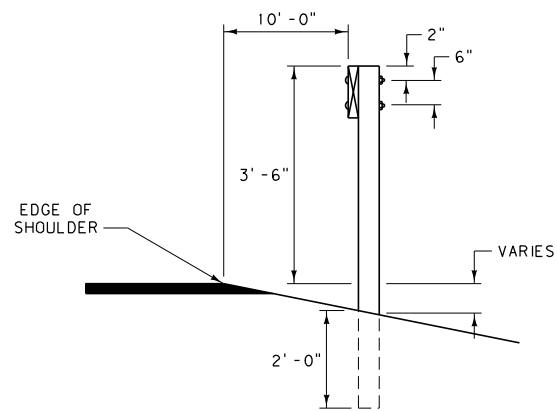

RIGHT SIDE VIEW

BARRICADE DETAILS

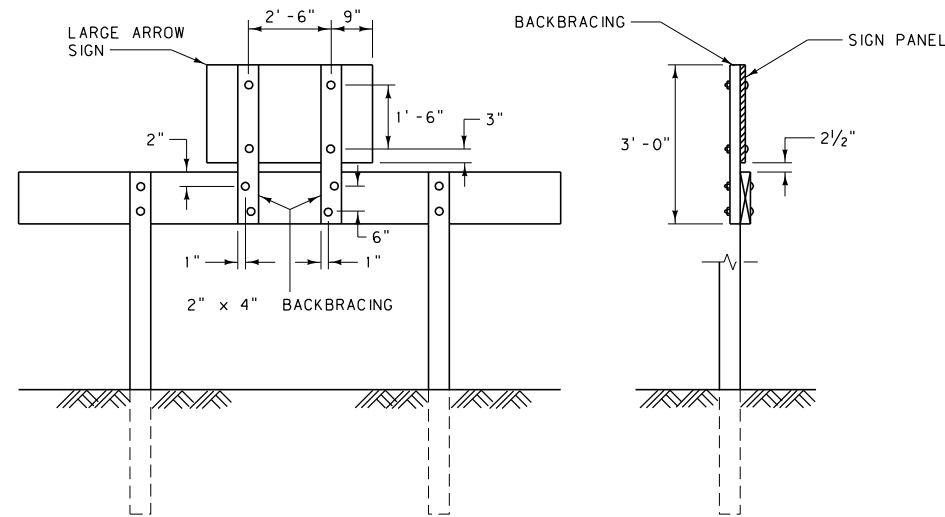

REAR VIEW

LEFT SIDE VIEW

SIGN MOUNTING DETAILS

NOTES:

CONSTRUCT ALL BARRICADES OF COMMERCIAL GRADE S4S LUMBER. USE 3/8" DIA. GALVANIZED CARRIAGE OR CADMIUM PLATED BOLTS, WASHERS AND NUTS FOR ALL CONNECTIONS.

PAINT ALL BARRICADES WITH TWO COATS OF WHITE PAINT IN ACCORDANCE WITH SECTION 710 OF THE STANDARD SPECIFICATIONS.

ALL BARRICADES HAVE ALTERNATING RETRO-REFLECTIVE RED AND WHITE STRIPES, 6" IN WIDTH AT AN ANGLE OF 45° TO THE VERTICAL, SLANTING DOWNWARD TOWARD THE SIDE OR SIDES ON WHICH TRAFFIC IS TO FLOW. NOMINAL DIMENSIONS OF ROLL MATERIAL FOR STRIPES IS ACCEPTABLE.

BARRICADES DESIGNATED "L" ARE PLACED ON THE LEFT SIDE OF APPROACHING TRAFFIC. BARRICADES DESIGNATED "R" ARE PLACED ON THE RIGHT SIDE OF APPROACHING TRAFFIC.

RETRO-REFLECTORIZE ALL BARRICADES WITH THE SHEETING MOUNTED ON A SHEET ALUMINUM BACKING AT LEAST 0.019" THICK. USE ALUMINUM ALLOY 6061-T6 OR AA5052-H38 CONFORMING TO ASTM DESIGNATION B 209. SECURE RETRO-REFLECTIVE ALUMINUM SHEETING WITH ALUMINUM NAILS.

DETERMINE THE POST LENGTHS IN THE FIELD, COMPLYING WITH THE MOUNTING HEIGHTS AND FOUNDATION DEPTHS LISTED ON THIS SHEET.

BIII BARRICADE
B (III)-L & R SHOWN

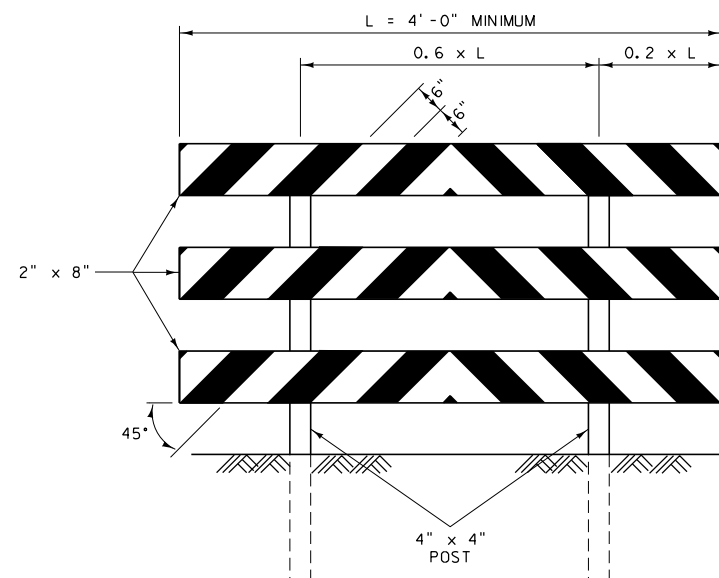

FRONT VIEW

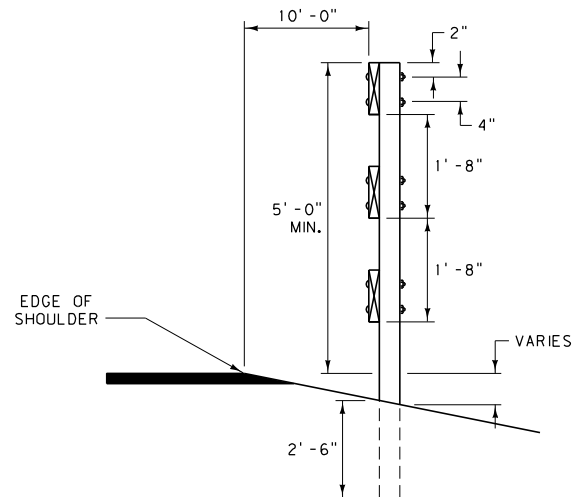

RIGHT SIDE VIEW

BARRICADE DETAILS

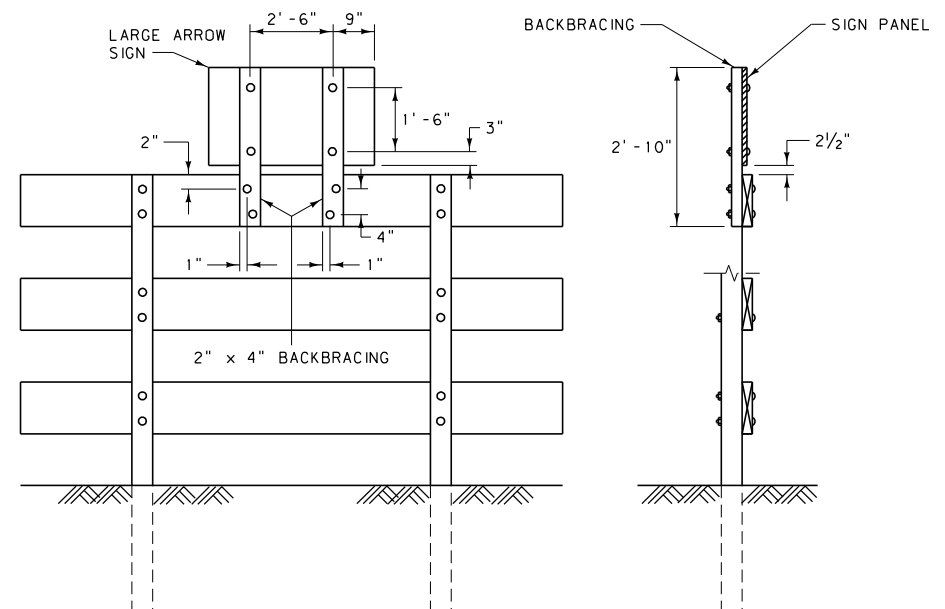

REAR VIEW

LEFT SIDE VIEW

SIGN MOUNTING DETAILS

DETAILED DRAWING	
REFERENCE	DWG. NO.
STANDARD SPEC.	619-42
SECTION 619	

PERMANENT BARRICADE
DESIGN DETAILS

EFFECTIVE: FEBRUARY 2005

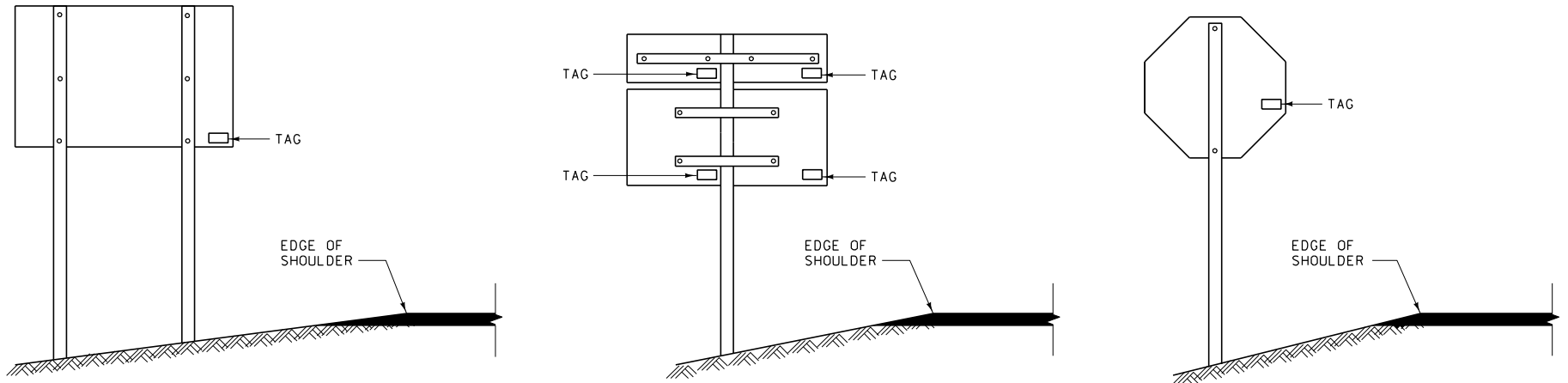

PLACEMENT DETAILS

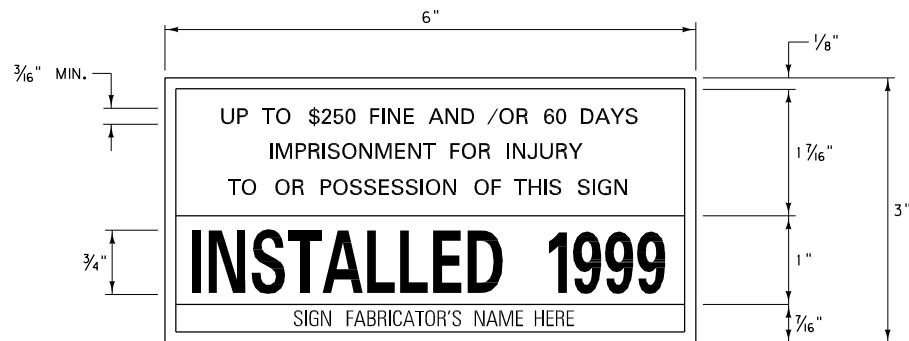

DATE TAG DETAIL

NOTES:

FURNISH AND PLACE INSTALLATION DATE TAGS ON ALL SIGNS PRIOR TO FINAL ACCEPTANCE OF THE PROJECT.

THE TAGS DISPLAY THE YEARS IN WHICH THE SIGNS WERE INSTALLED. SEE THE COLOR SEQUENCE TABLE SHOWN ON THIS DRAWING FOR THE APPROPRIATE COLORS. DATE TAGS ARE TO BE RETRO-REFLECTIVE.

PLACE A TAG ON THE BACK OF EACH SIGN, LOCATED NEAR THE LOWER CORNER OF THE SIGN NEAREST THE EDGE OF ROADWAY, TO BE VISIBLE FROM THE ROADWAY AS SHOWN IN THE EXAMPLES ABOVE.

PLACE TAGS ON ANY NEW SIGN INSTALLED IN THE FIELD AS ROUTINE MAINTENANCE BY MDT FORCES. MAINTENANCE DESIGN DATE TAGS CAN BE ORDERED FROM THE SIGN SHOP IN HELENA.

DATE TAG COLOR SEQUENCE

DATE TAG COLOR CORRESPONDS TO THE LAST DIGIT OF THE INSTALLATION YEAR AS FOLLOWS:

- | | |
|-----------------|------------|
| 0 - YELLOW | 5 - RED |
| 1 - WHITE | 6 - PURPLE |
| 2 - LIGHT BLUE | 7 - ORANGE |
| 3 - GOLD | 8 - BLUE |
| 4 - LIGHT GREEN | 9 - GREEN |

DETAILED DRAWING	
REFERENCE STANDARD SPEC. SECTION 619	DWG. NO. 619-44
INSTALLATION DATE TAGS	
EFFECTIVE: FEBRUARY 2005	
 MONTANA DEPARTMENT OF TRANSPORTATION <i>serving you with pride</i>	