

B(I)-R

B(II)-R

B(III)-L

PORTABLE BARRICADES

PORTABLE BARRICADE NOTES:

- ① RAIL STRIPES ARE 6" IN WIDTH FOR BARRICADES 3' OR GREATER IN LENGTH. FOR BARRICADES LESS THAN 3' IN LENGTH, 4" STRIPES MAY BE USED.
- ② THE PREDOMINANT COLOR FOR OTHER BARRICADE COMPONENTS IS WHITE, BUT UNPAINTED GALVANIZED METAL OR ALUMINUM COMPONENTS MAY BE USED.
- ③ WHERE B(III) BARRICADES ARE TO FACE TRAFFIC FROM TWO DIRECTIONS, STRIPING ON BOTH THE FRONT AND REAR SIDES IS REQUIRED.
- ④ USE MATERIALS FOR BARRICADE FRAMEWORK AND ASSEMBLY, INCLUDING ANY SIGNS AND MEANS OF ATTACHMENT, THAT MEET THE REQUIREMENTS FOR NCHRP 350 FOR WORK ZONE DEVICES. ALTERNATIVELY, SIGNS AND BARRICADES MAY BE MOUNTED DIRECTLY BEHIND BARRICADES ON SEPARATE SIGN SUPPORTS.
- ⑤ USE SANDBAGS OF SUFFICIENT WEIGHT TO HOLD THE BARRICADES IN PLACE. WATERPROOF SANDBAGS DURING PERIODS OF FREEZING WEATHER.
- ⑥ BARRICADES DESIGNATED "R" ARE PLACED TO THE RIGHT SIDE OF APPROACHING TRAFFIC. THOSE DESIGNATED "L" ARE PLACED TO THE LEFT SIDE.
- ⑦ USE RETRO-REFLECTIVE SHEETING AS PER THE CONTRACT.

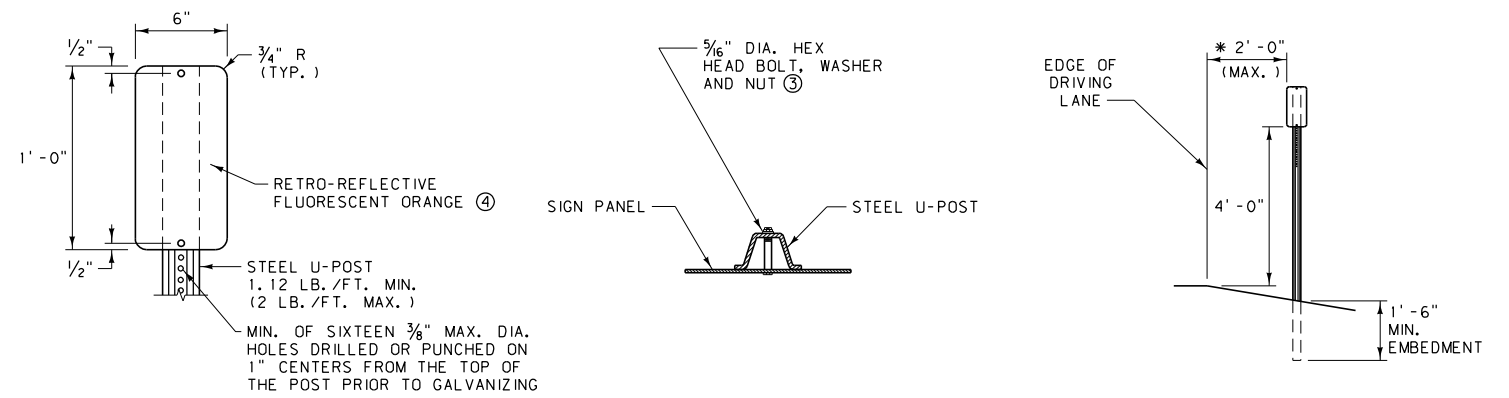

TYPE 2 OBJECT MARKER

TYPE 2 OBJECT MARKER NOTES:

- ① USE TYPE 2 OBJECT MARKERS TO DELINEATE ROADSIDE CONSTRUCTIONS OF THE CLEAR ZONE (I.E. DROP OFFS, OBSTACLES, ABRUPT CHANGES IN ROADWAY ALIGNMENT, ETC.)
- ② DO NOT USE TYPE 2 OBJECT MARKERS AS CHANNELIZING DEVICES.
- ③ ATTACH PANELS TO POSTS AT BOTH TOP AND BOTTOM HOLE LOCATIONS.
- ④ USE RETRO-REFLECTIVE SHEETING AS PER THE CONTRACT.
- * REDUCE OR ELIMINATE THE 2'-0" DISTANCE WHEN OBSTACLE OR HAZARD IS LESS THAN 2'-0" FROM THE EDGE OF THE DRIVING LANE.

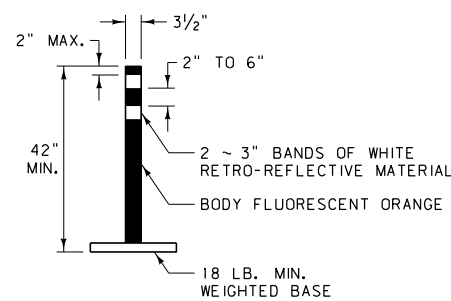

FLEXIBLE GUIDE POST (TUBULAR MARKER)

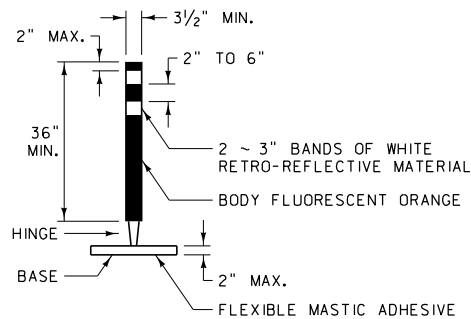

HINGED FLEXIBLE GUIDE POST (TUBULAR MARKER) (SELF RIGHTING AFTER IMPACT)

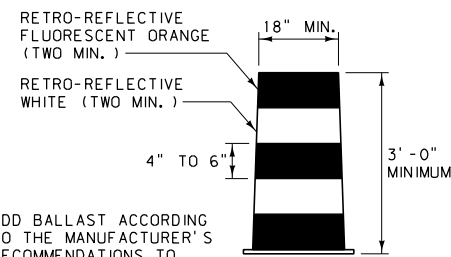

ADD BALLAST ACCORDING TO THE MANUFACTURER'S RECOMMENDATIONS TO HOLD THE DRUM IN PLACE. DRUMS HAVE CLOSED TOPS.

PLASTIC DRUM

FLEXIBLE GUIDE POST AND PLASTIC DRUM NOTES:

- ① USE FLEXIBLE GUIDE POSTS AND PLASTIC DRUMS AS CHANNELIZING DEVICES.
- ② USE ASTM TYPE III RETRO-REFLECTIVE SHEETING ON ALL PLASTIC DRUMS AND FLEXIBLE GUIDE POSTS.

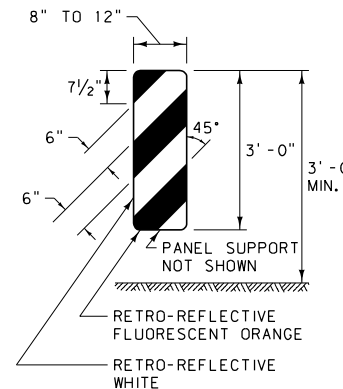

PORTABLE VERTICAL PANEL (VP-1R SHOWN. REVERSE FOR VP-1L.)

PORTABLE VERTICAL PANEL NOTES:

- ① USE PORTABLE VERTICAL PANELS AS CHANNELIZING DEVICES ONLY. DO NOT USE PORTABLE VERTICAL PANELS TO DELINEATE ROADSIDE CONSTRUCTIONS OF THE CLEAR ZONE.
- ② VERTICAL PANELS DESIGNATED "R" ARE PLACED TO THE RIGHT SIDE OF APPROACHING TRAFFIC. THOSE DESIGNATED "L" ARE PLACED TO THE LEFT SIDE.
- ③ USE RETRO-REFLECTIVE SHEETING AS PER THE CONTRACT.

GENERAL NOTES:

- ① SEE THE MANUAL ON UNIFORM TRAFFIC CONTROL DEVICES (MUTCD) PART 6 FOR ADDITIONAL INFORMATION.

| | |
|---|-----------------|
| DETAILED DRAWING | |
| REFERENCE STANDARD SPEC. SECTION 618 | DWG. NO. 618-00 |
| BARRICADES, CHANNELIZING DEVICES AND OBJECT MARKERS | |
| EFFECTIVE: APRIL 2006 | |
| MONTANA DEPARTMENT OF TRANSPORTATION | |

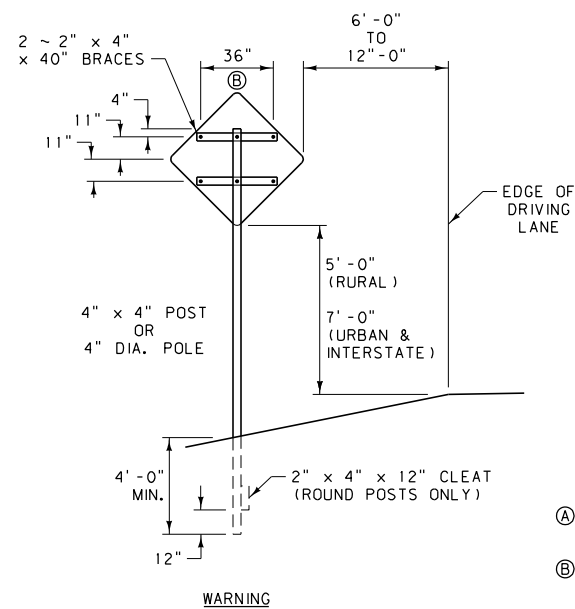

Ⓐ ALL WARNING SIGNS ARE 48" x 48" IN SIZE.
 Ⓑ DIMENSIONS ARE FROM Ⓢ BOLT TO Ⓢ BOLT.

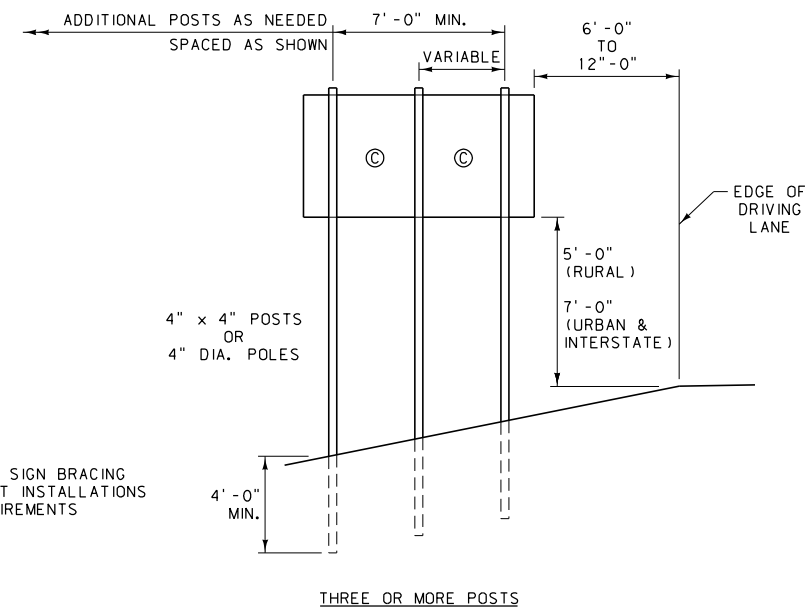
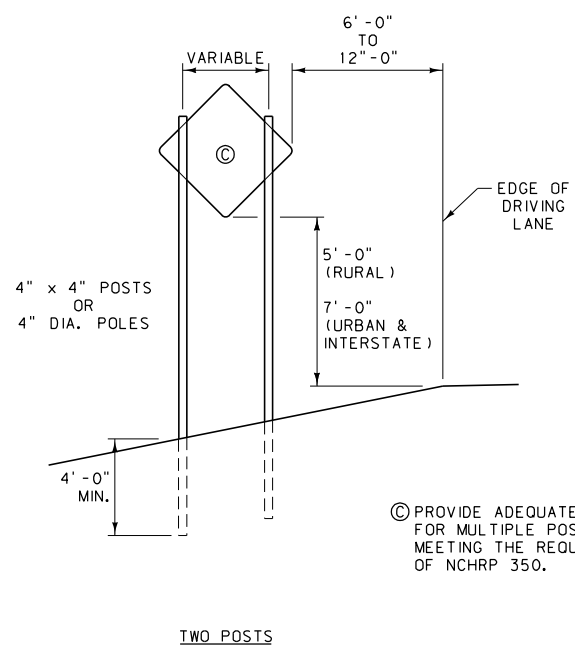
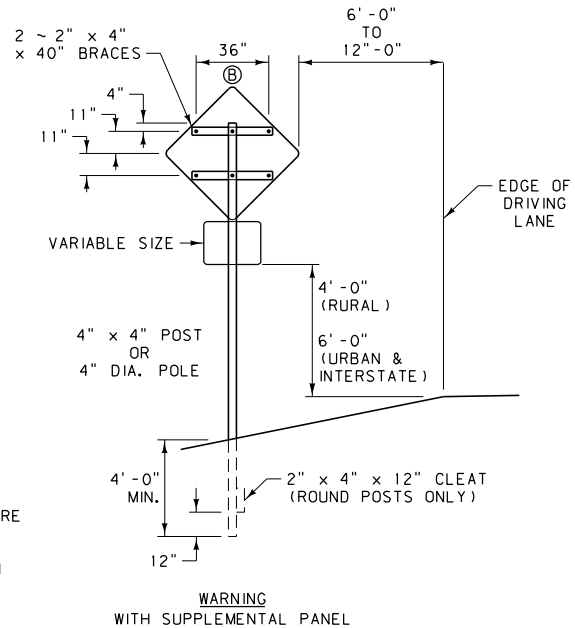

TYPICAL MULTIPLE POST INSTALLATIONS
 (FOR CONSTRUCTION SIGNING ONLY)

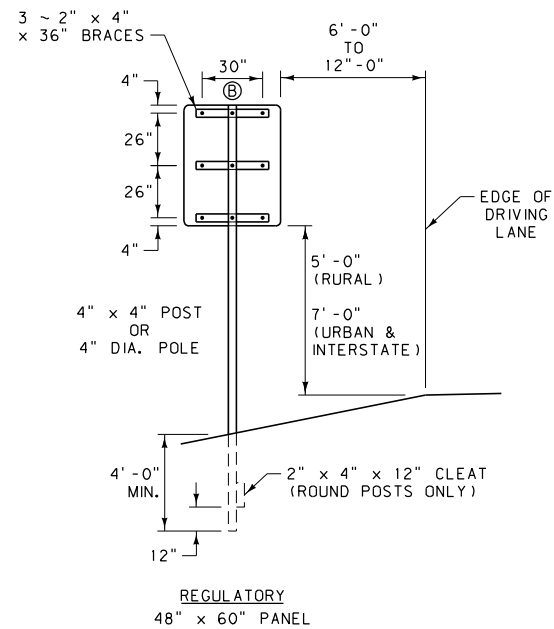

REGULATORY
 48" x 60" PANEL

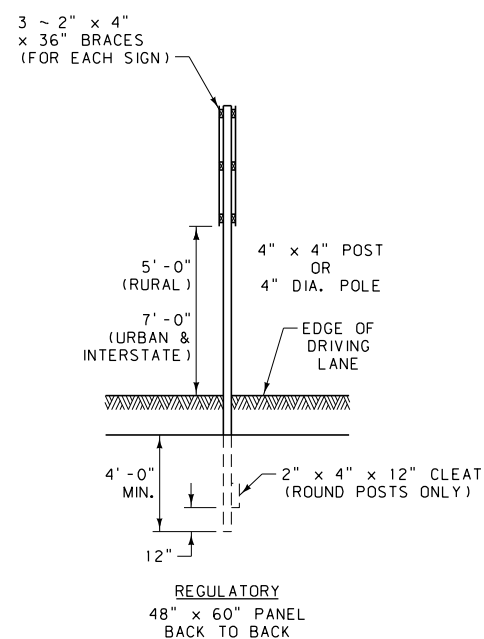

REGULATORY
 48" x 60" PANEL
 BACK TO BACK

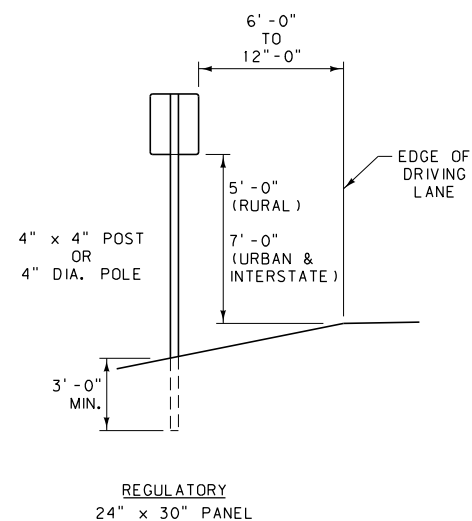

REGULATORY
 24" x 30" PANEL

TYPICAL SIGN MOUNTINGS
 (FOR CONSTRUCTION SIGNING ONLY)

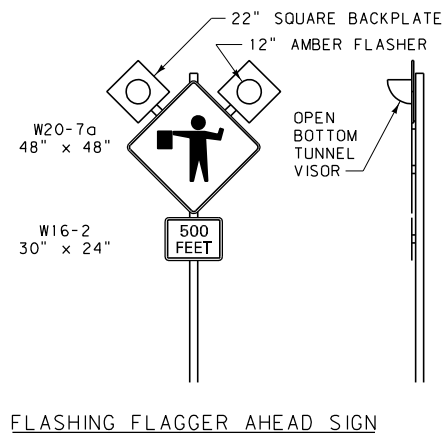

FLASHING FLAGGER AHEAD SIGN

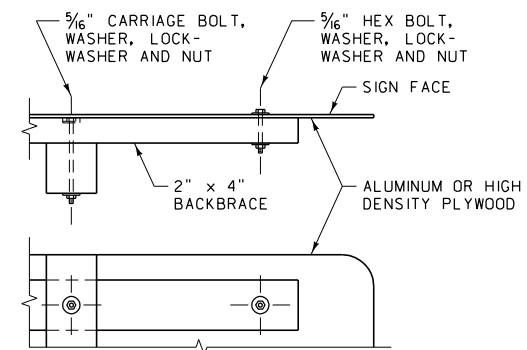

SIGN FASTENING DETAILS

NOTES:

- ① FURNISH AND INSTALL POSTS OR POLES MEETING NCHRP 350 REQUIREMENTS.
- ② FURNISH POST OR POLE LENGTHS TO ACCOMMODATE THE FOUNDATION DEPTH, THE MOUNTING HEIGHT AND THE MOUNTINGS
- ③ BACKFILL FOUNDATION HOLES IN 8" LIFTS, THOROUGHLY TAMPING EACH LIFT.
- ④ IN HIGH WIND AREAS INSTALL LARGER POSTS OR POLES COMPLYING WITH THE FOUNDATION AND BREAKAWAY REQUIREMENTS OF DTL. DWG. NO. 619-20. THE MINIMUM POST SPACING FOR MULTIPLE POSTS LARGER THAN 4" IS 7'-0".
- ⑤ VERTICAL ALIGNMENT OF SIGNS IS TO BE WITHIN 5' OF PLUMB (1" IN 1').
- ⑥ USE THE URBAN MOUNTING HEIGHTS IN BUSINESS, COMMERCIAL, AND RESIDENTIAL DISTRICTS WHERE PARKING AND/OR PEDESTRIAN MOVEMENT IS LIKELY TO OCCUR, OR WHERE THERE ARE OTHER OBSTRUCTIONS TO VIEW. URBAN MOUNTING HEIGHTS MAY ALSO BE USED IN RURAL AREAS FOR INCREASED VISIBILITY.

| | |
|---|-----------------|
| DETAILED DRAWING | |
| REFERENCE STANDARD SPEC. SECTION 618 | DWG. NO. 618-01 |
| CONSTRUCTION SIGN DETAILS | |
| EFFECTIVE: FEBRUARY 2005 | |
|  MONTANA DEPARTMENT OF TRANSPORTATION <i>-serving you with pride-</i> | |

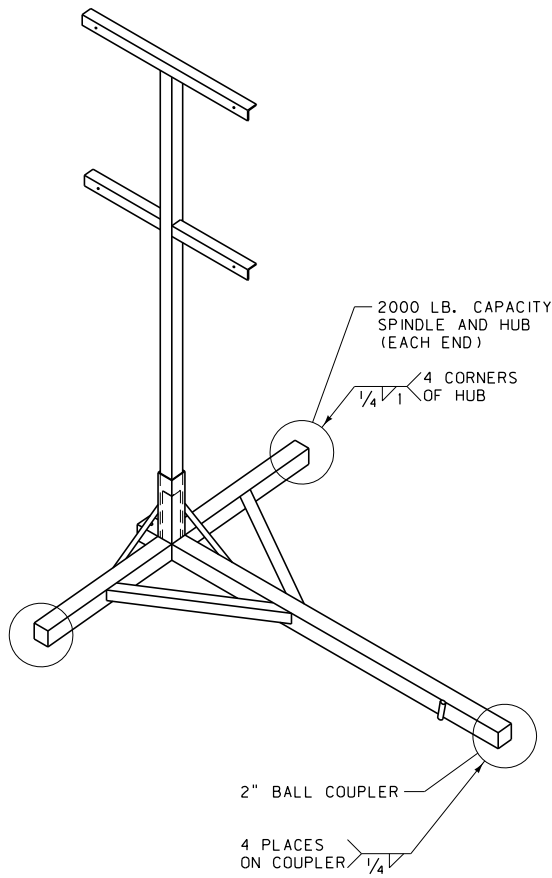

NOTES:

- ① THE MAXIMUM WEIGHT OF THE ASSEMBLY IS 250 POUNDS.
- ② USE A 14" WHEEL AND TIRE.
- ③ AUTOMOTIVE AND EQUIPMENT AXLE ASSEMBLIES MAY NOT BE USED FOR TRAILER-MOUNTED SIGN SUPPORTS.
- ④ OTHER NCHRP 350 CRASH TESTED ASSEMBLIES ARE ACCEPTABLE.

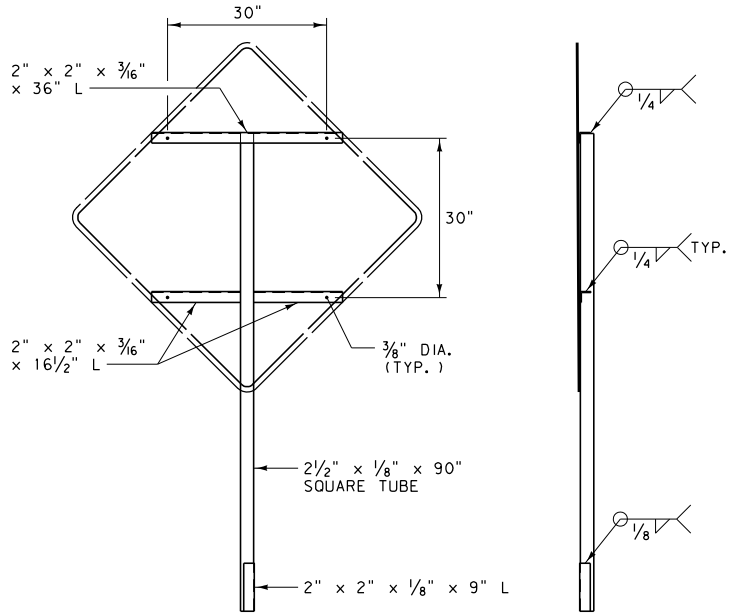

FRONT

RIGHT

SIGN SUPPORT

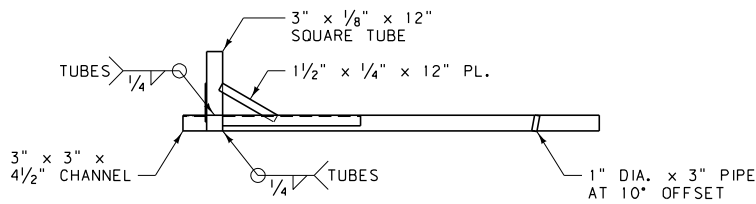

FRONT

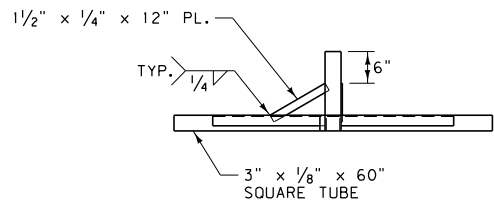

RIGHT

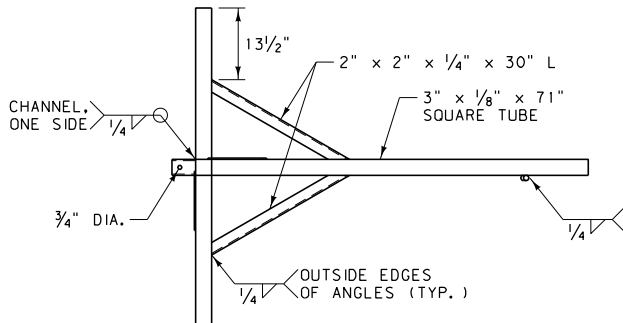

TOP

TRAILER

| | |
|--|-----------------|
| DETAILED DRAWING | |
| REFERENCE STANDARD SPEC. SECTION 618.715 | DWG. NO. 618-02 |
| PORTABLE SIGN SUPPORT ASSEMBLY | |
| EFFECTIVE: FEBRUARY 2005 | |
|  MONTANA DEPARTMENT OF TRANSPORTATION <i>-serving you with pride</i> | |

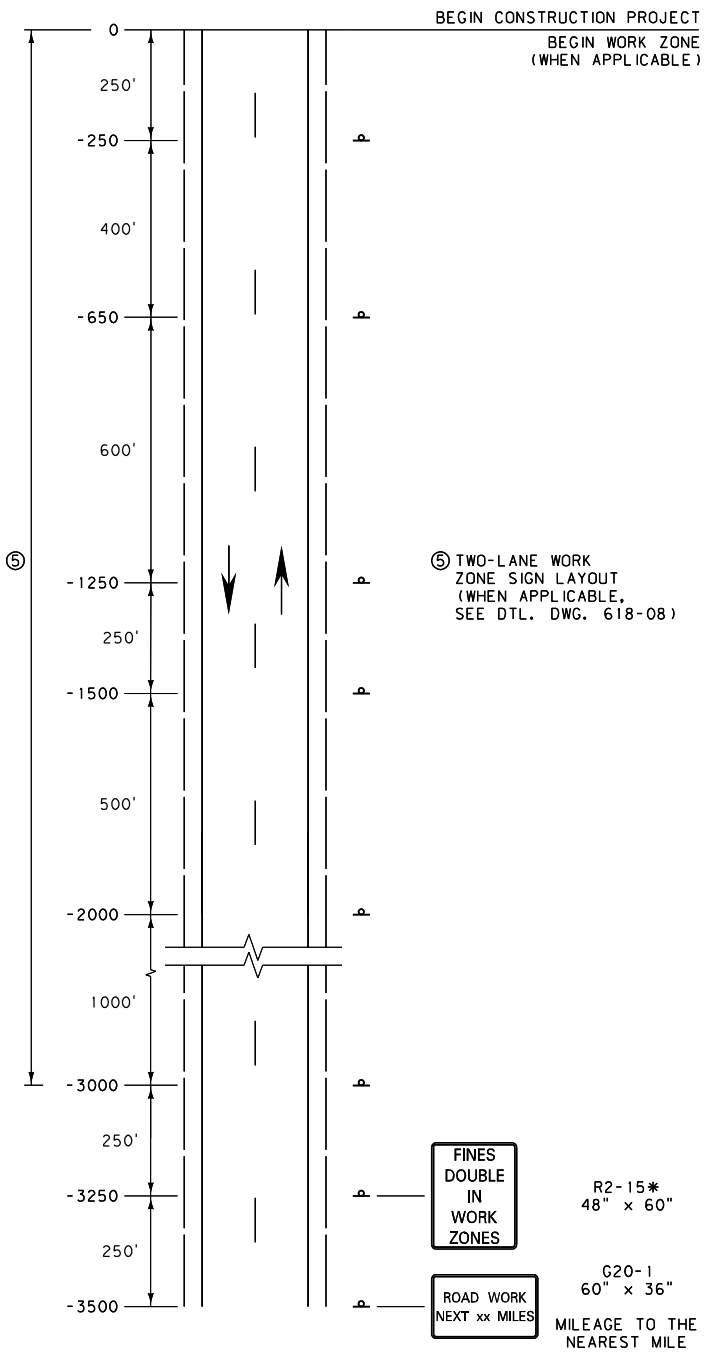
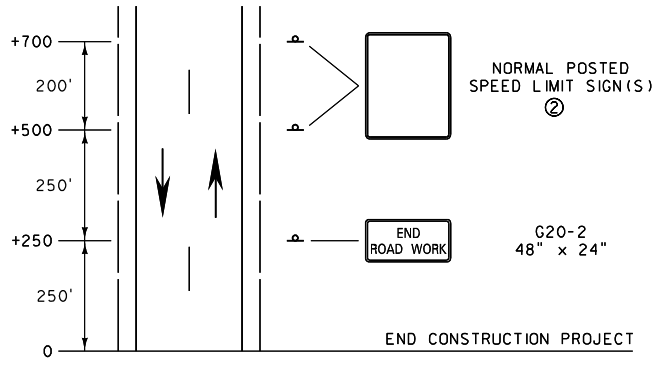

NOTES:

- ① THIS SIGN LAYOUT IS INTENDED TO BE A PERMANENT INSTALLATION FOR THE DURATION OF THE CONSTRUCTION PROJECT, AS APPROVED BY THE ENGINEER. COVER OR REMOVE ANY SIGNS WHEN NOT IN USE, INCLUDING SPEED LIMIT SIGNS NOT WARRANTED. REMOVE ANY SIGN SUPPORTS IF THEY WILL NOT BE NEEDED WITHIN 90 DAYS.
 - ② POST THE END OF CONSTRUCTION PROJECT SPEED LIMIT CONSISTING OF ONE SIGN WHEN THE NORMAL POSTED SPEED LIMIT FOR ALL VEHICLES IS THE SAME. USE TWO SIGNS WHEN CAR, TRUCK AND NIGHTTIME SPEED LIMITS ARE DIFFERENT.
 - ③ INCLUDE REGULATORY SIGNING ONLY IF THE CONSTRUCTION PROJECT CONTAINS A WORK ZONE OR HAS ROADWAY CONDITIONS THAT WARRANT SPEED RESTRICTIONS. MODIFY REGULATORY SIGNS TO MATCH ADJACENT REGULATIONS.
 - ④ THE WORK ZONE REFERS TO THE AREA WITHIN THE CONSTRUCTION PROJECT WHERE WORK IS ACTUALLY TAKING PLACE.
 - ⑤ IN ADDITION TO THE SIGNS SHOWN, INCLUDE THE APPROPRIATE TWO-LANE WORK ZONE SIGNS (DTL. DWG. NO. 618-08) WHEN A WORK ZONE IS LOCATED AT THE BEGINNING OR END OF THE CONSTRUCTION PROJECT.
 - ⑥ SET UP THIS SIGN LAYOUT IN EACH TRAFFIC DIRECTION.
- * DENOTES SIGNS THAT ARE UNIQUE TO MONTANA.

| | |
|---|-----------------|
| DETAILED DRAWING | |
| REFERENCE STANDARD SPEC. SECTION 618 | DWG. NO. 618-04 |
| TWO-LANE CONSTRUCTION PROJECT | |
| EFFECTIVE: APRIL 2006 | |
| MONTANA DEPARTMENT OF TRANSPORTATION <i>servicing you with pride</i> | |

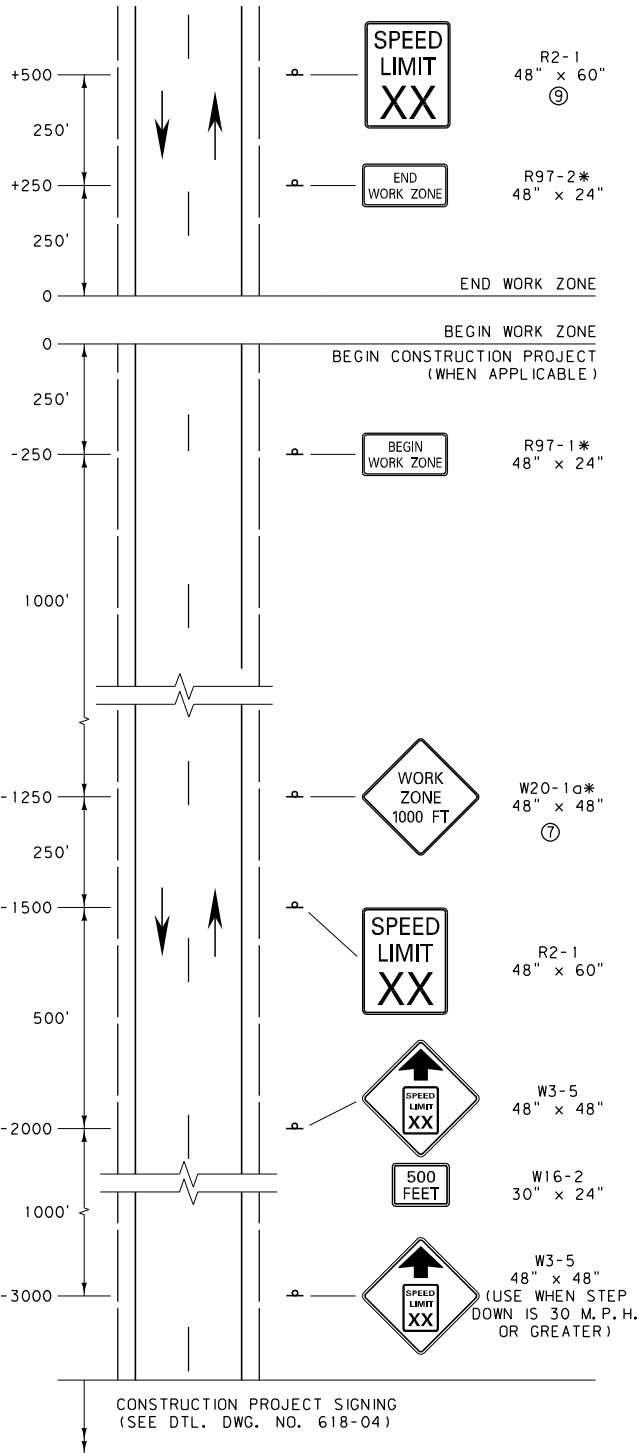

WORK ZONE WITH NO FLAGGER

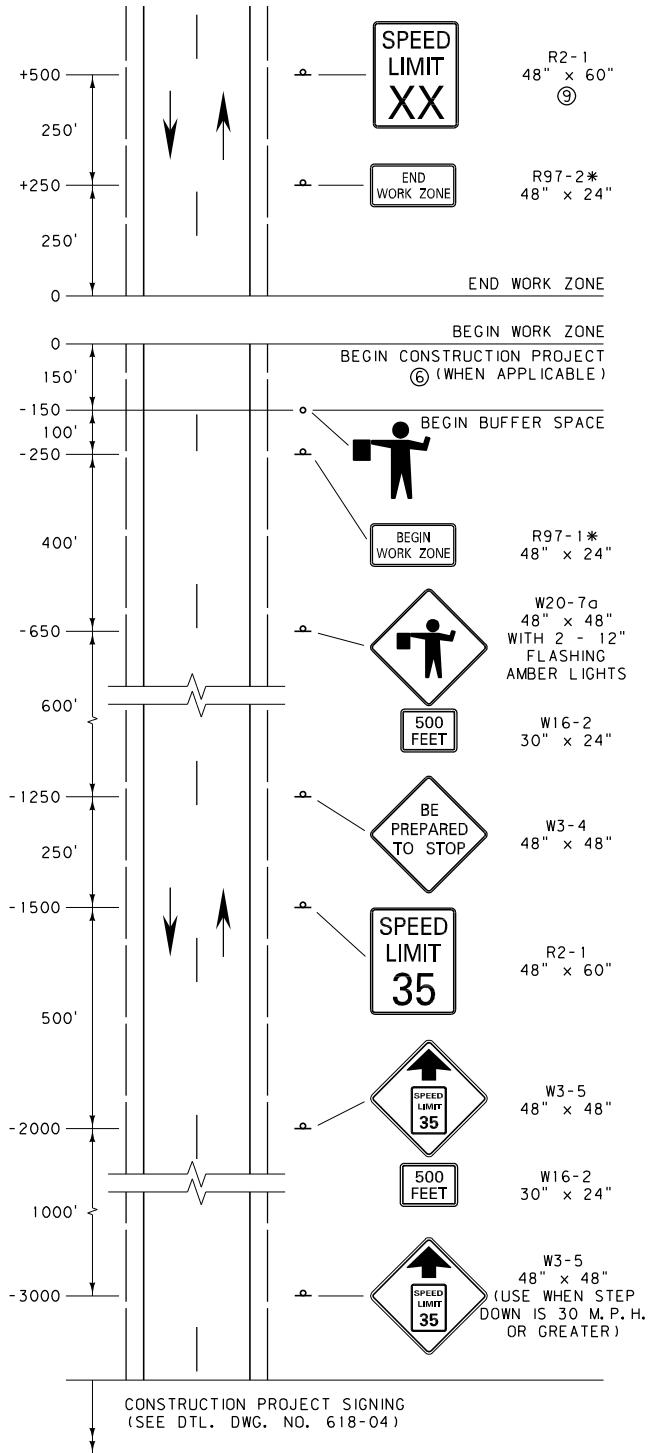

WORK ZONE WITH FLAGGER

NOTES:

- ① THESE SIGN LAYOUTS WORK IN CONJUNCTION WITH THE PERMANENT LAYOUT ILLUSTRATED ON DTL. DWG. NO. 618-04 FOR WORK ZONES LOCATED AT THE BEGIN AND END OF THE CONSTRUCTION PROJECT.
- ② XX = SPEED DETERMINED BY THE ENGINEER.
- ③ INCLUDE REGULATORY SIGNING ONLY IF THERE IS REASON TO RESTRICT SPEED WITHIN THE WORK ZONE. MODIFY REGULATORY SIGNS TO MATCH ADJACENT REGULATIONS.
- ④ SET UP THIS SIGN LAYOUT IN EACH TRAFFIC DIRECTION. COMBINE SUCCESSIVE WORK ZONES WHEN LESS THAN 1.0 MILE APART.
- ⑤ THE WORK ZONE REFERS TO THE AREA WITHIN THE CONSTRUCTION PROJECT WHERE WORK IS ACTUALLY TAKING PLACE.

- ⑥ THE BUFFER SPACE MAY BE INCREASED FOR DOWNGRADES AND OTHER CONDITIONS THAT AFFECT STOPPING DISTANCE.
- ⑦ USE MORE SPECIFIC SIGNS, WHERE APPLICABLE, SUCH AS W8-3 "PAVEMENT ENDS."
- ⑧ PROVIDE A SECOND FLAGGER WHEN REQUIRED BY STANDARD SPECIFICATIONS, SECTION 618.
- ⑨ POST THE END OF WORK ZONE SPEED LIMIT APPROPRIATE FOR ALL VEHICLES FOR THE REMAINDER OF THE CONSTRUCTION PROJECT BEFORE RESUMING TO NORMAL POSTED SPEED LIMITS AT THE END OF THE CONSTRUCTION PROJECT.

* DENOTES SIGNS THAT ARE UNIQUE TO MONTANA.

| DETAILED DRAWING | |
|--|-----------------|
| REFERENCE STANDARD SPEC. SECTION 618 | DWG. NO. 618-08 |
| TWO-LANE CONSTRUCTION PROJECT WORK ZONES | |

EFFECTIVE: APRIL 2006

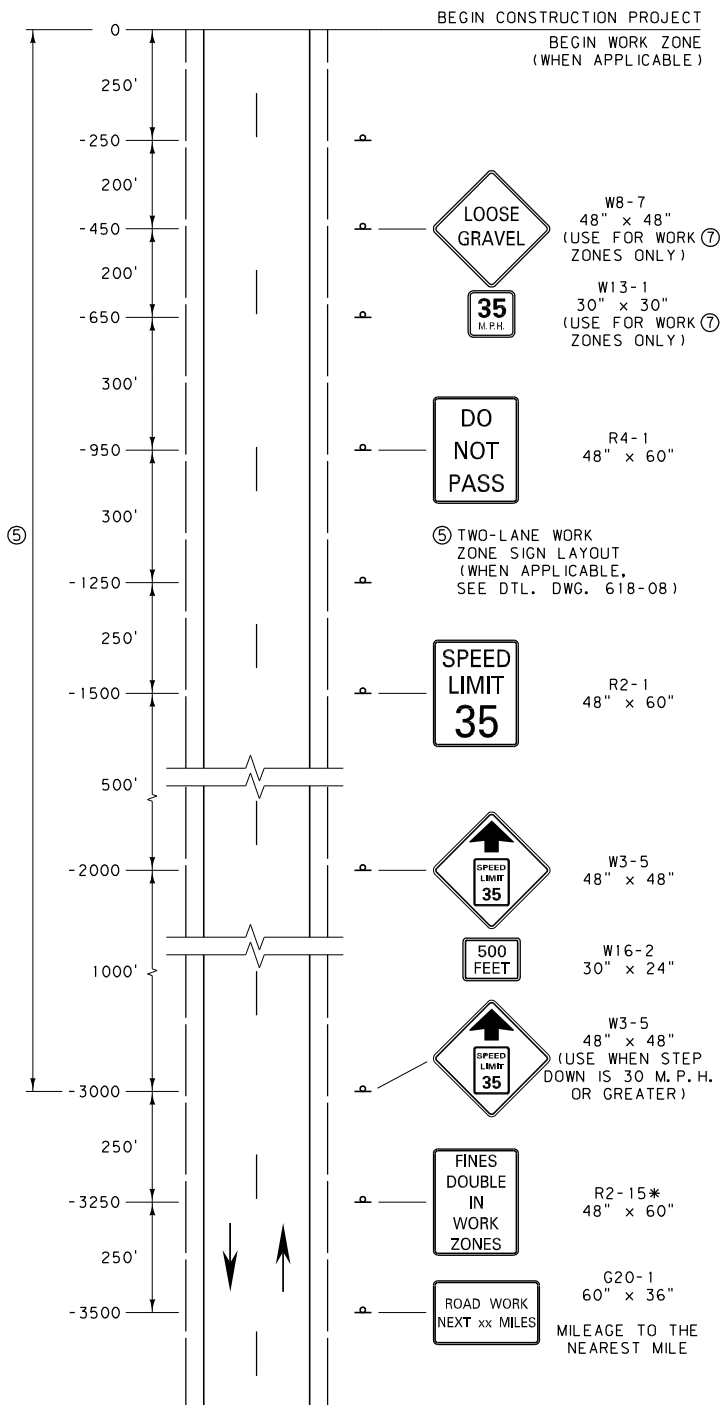
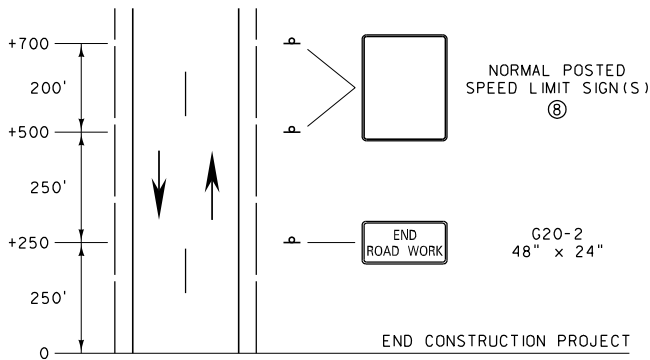

NOTES:

- ① THIS SIGN LAYOUT WORKS IN CONJUNCTION WITH THE PERMANENT LAYOUT ILLUSTRATED ON DTL. DWG. NO. 618-04. COVER OR REMOVE SIGNS WHEN NOT IN USE, INCLUDING SPEED LIMIT SIGNS NOT WARRANTED.
 - ② INCLUDE REGULATORY SIGNING ONLY IF THERE IS REASON TO RESTRICT SPEED WITHIN THE CONSTRUCTION PROJECT. MODIFY REGULATORY SIGNS TO MATCH ADJACENT REGULATIONS.
 - ③ THE WORK ZONE REFERS TO THE AREA WITHIN THE CONSTRUCTION PROJECT WHERE WORK IS ACTUALLY TAKING PLACE.
 - ④ FOR SEAL COAT WORK ZONE ACTIVITIES, USE THE FLAGGER APPLICATION OF THE WORK ZONE LAYOUT FROM DTL. DWG. NO. 618-08.
 - ⑤ IN ADDITION TO THE SIGNS SHOWN, INCLUDE THE APPROPRIATE TWO-LANE WORK ZONE SIGNS WHEN A WORK ZONE IS LOCATED AT THE BEGINNING OR END OF THE CONSTRUCTION PROJECT.
 - ⑥ SET UP THIS SIGN LAYOUT IN EACH TRAFFIC DIRECTION.
 - ⑦ PLACE THE W8-7 AND W13-1 SIGNS AT THE BEGINNING OF EACH WORK ZONE AND AT 2.0 MILE INTERVALS WITHIN THE WORK ZONES FOR EACH DIRECTION OF TRAVEL.
 - ⑧ POST THE END OF CONSTRUCTION PROJECT SPEED LIMIT CONSISTING OF ONE SIGN WHEN THE NORMAL POSTED SPEED LIMIT FOR ALL VEHICLES IS THE SAME. USE TWO SIGNS WHEN CAR, TRUCK AND NIGHTTIME SPEED LIMITS ARE DIFFERENT.
- * DENOTES SIGNS THAT ARE UNIQUE TO MONTANA.

| | |
|---|-----------------|
| DETAILED DRAWING | |
| REFERENCE STANDARD SPEC. SECTION 618 | DWG. NO. 618-10 |
| TWO-LANE CONSTRUCTION PROJECT SEAL COAT | |
| EFFECTIVE: APRIL 2006 | |
| MONTANA DEPARTMENT OF TRANSPORTATION <i>servicing you with pride</i> | |

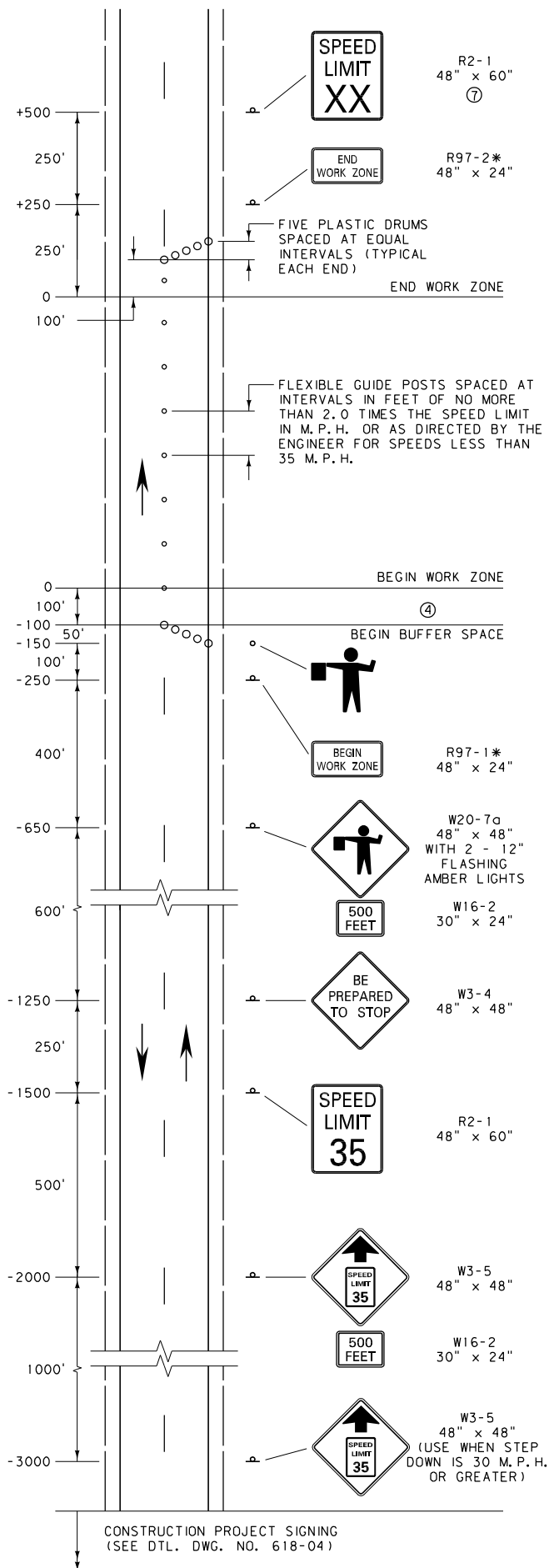

NOTES:

- ① MODIFY REGULATORY SIGNS TO MATCH ADJACENT REGULATIONS.
- ② SET UP THIS SIGN LAYOUT IN EACH TRAFFIC DIRECTION.
- ③ THE WORK ZONE REFERS TO THE AREA WITHIN THE CONSTRUCTION PROJECT WHERE WORK IS ACTUALLY TAKING PLACE.
- ④ THE BUFFER SPACE MAY BE INCREASED FOR DOWNGRADES AND OTHER CONDITIONS THAT AFFECT STOPPING DISTANCE.
- ⑤ PROVIDE A SECOND FLAGGER WHEN REQUIRED BY STANDARD SPECIFICATIONS, SECTION 618.
- ⑥ XX = SPEED DETERMINED BY THE ENGINEER.
- ⑦ POST THE END OF WORK ZONE SPEED LIMIT APPROPRIATE FOR ALL VEHICLES FOR THE REMAINDER OF THE CONSTRUCTION PROJECT BEFORE RESUMING TO NORMAL POSTED SPEED LIMITS AT THE END OF THE CONSTRUCTION PROJECT.

* DENOTES SIGNS THAT ARE UNIQUE TO MONTANA.

CONSTRUCTION PROJECT SIGNING
(SEE DTL. DWG. NO. 618-04)

| | |
|---|--------------------------------------|
| DETAILED DRAWING | |
| REFERENCE STANDARD SPEC. SECTION 618 | DWG. NO. 618-12 |
| TWO-LANE CONSTRUCTION PROJECT LANE CLOSURE-FLAGGER CONTROLLED | |
| EFFECTIVE: APRIL 2006 | |
|  | MONTANA DEPARTMENT OF TRANSPORTATION |

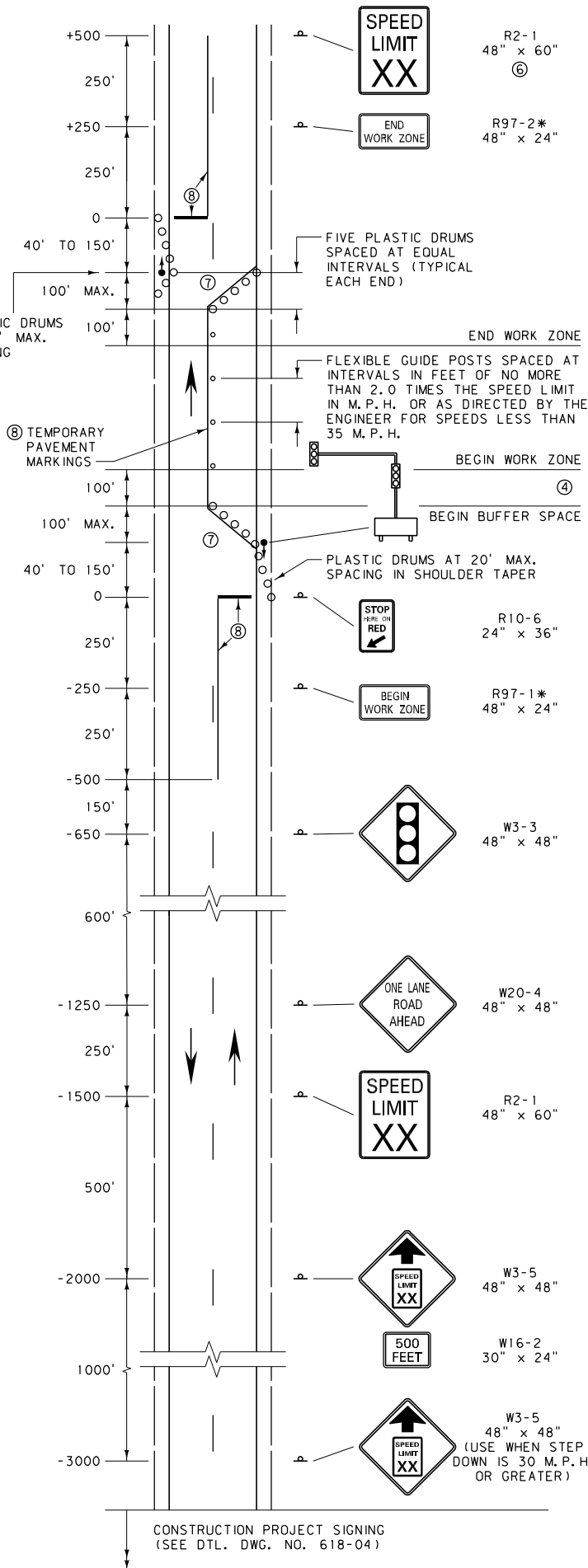

CONSTRUCTION PROJECT SIGNING
(SEE DTL. DWG. NO. 618-04)

NOTES:

- ① MODIFY REGULATORY SIGNS TO MATCH ADJACENT REGULATIONS.
- ② SET UP THIS SIGN LAYOUT IN EACH TRAFFIC DIRECTION.
- ③ THE WORK ZONE REFERS TO THE AREA WITHIN THE CONSTRUCTION PROJECT WHERE WORK IS ACTUALLY TAKING PLACE.
- ④ THE BUFFER SPACE MAY BE INCREASED FOR DOWNGRADES AND OTHER CONDITIONS THAT AFFECT STOPPING DISTANCE.
- ⑤ XX = SPEED DETERMINED BY THE ENGINEER.
- ⑥ POST THE END OF WORK ZONE SPEED LIMIT APPROPRIATE FOR ALL VEHICLES FOR THE REMAINDER OF THE CONSTRUCTION PROJECT BEFORE RESUMING TO NORMAL POSTED SPEED LIMITS AT THE END OF THE CONSTRUCTION PROJECT.
- ⑦ REMOVE ANY CONFLICTING PAVEMENT MARKINGS BETWEEN THE STOP LINE AND WORK ZONE BOUNDARY.
- ⑧ PLACE TEMPORARY PAVEMENT MARKINGS AS SHOWN WHEN ROADWAY SURFACE IS PAVED. (REMOVABLE PAVEMENT MARKINGS MAY BE USED.) UPON REMOVAL OF THE TEMPORARY TRAFFIC CONTROL SIGNALS, REMOVE ALL TEMPORARY PAVEMENT MARKINGS AND RESTORE PERMANENT OR INTERIM PAVEMENT MARKINGS.
- ⑨ TEMPORARY TRAFFIC CONTROL SIGNALS ARE TO MEET THE PHYSICAL DISPLAY AND OPERATIONAL REQUIREMENTS OF PERMANENT TRAFFIC CONTROL SIGNALS.
- ⑩ ESTABLISH TEMPORARY TRAFFIC CONTROL SIGNAL TIMING BY CONSULTING WITH AN AUTHORIZED TRAFFIC ENGINEER. ENSURE THAT THE DURATIONS OF RED CLEARANCE INTERVALS ARE ADEQUATE TO CLEAR THE ONE-LANE SECTION OF CONFLICTING VEHICLES. INCORPORATE SAFEGUARDS TO AVOID THE POSSIBILITY OF CONFLICTING SIGNAL INDICATIONS AT EACH END OF THE WORK ZONE.
- ⑪ INCORPORATE ANY SIDE APPROACH TRAFFIC THAT OCCURS WITHIN THE WORK ZONE BOUNDARIES INTO THE MAINLINE SIGNAL CONTROLLED OPERATION VIA THE USE OF TEMPORARY TRAFFIC CONTROL SIGNS, DEVICES, ETC.

* DENOTES SIGNS THAT ARE UNIQUE TO MONTANA.

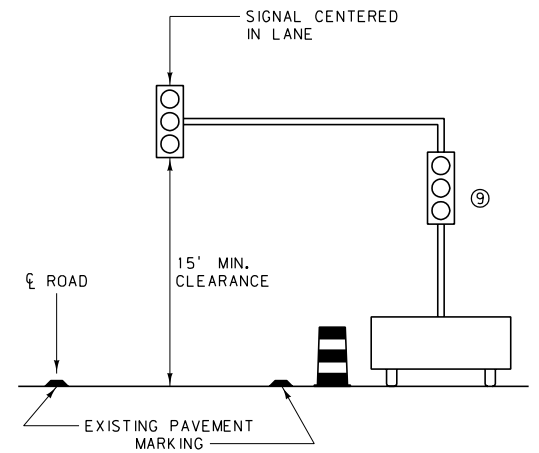

TEMPORARY TRAFFIC CONTROL SIGNAL DETAIL

| DETAILED DRAWING | |
|--|-----------------|
| REFERENCE STANDARD SPEC. SECTION 618 | DWG. NO. 618-13 |
| TWO-LANE CONSTRUCTION PROJECT LANE CLOSURE-SIGNAL CONTROLLED | |
| EFFECTIVE: APRIL 2006 | |
|  MONTANA DEPARTMENT OF TRANSPORTATION <i>servicing you with pride</i> | |

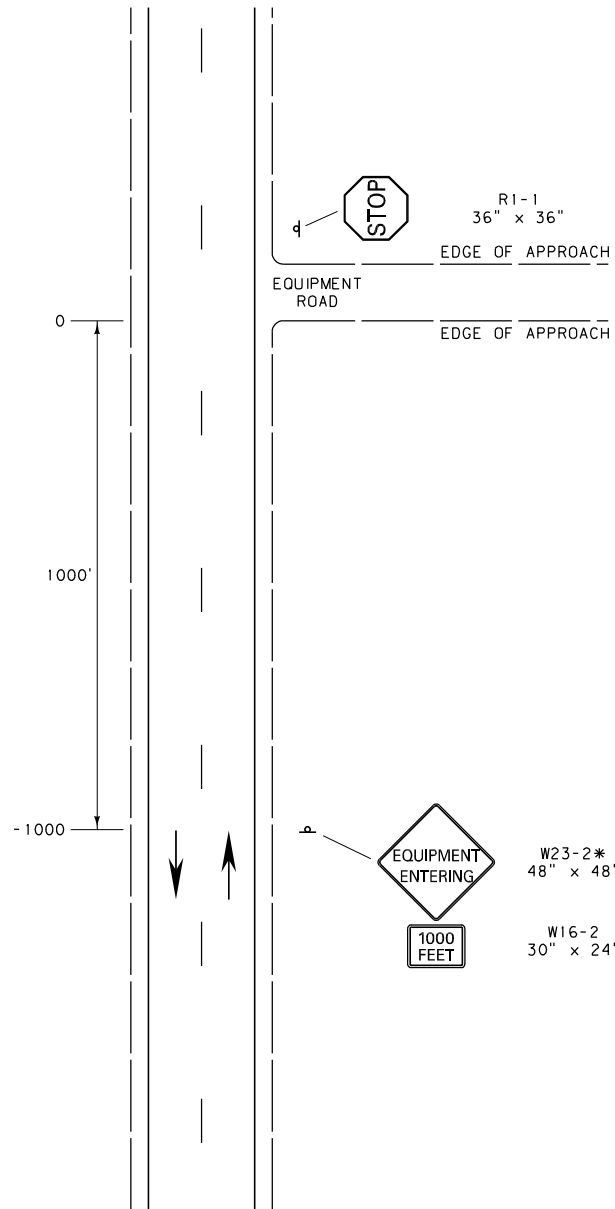

NOTES:

- ① USE THIS SIGN LAYOUT WHEN APPROPRIATE. OTHERWISE REFER TO DTL. DWG. NO. 618-16 WHEN A FLAGGER IS NEEDED.
 - ② SET UP THIS SIGN LAYOUT IN EACH TRAFFIC DIRECTION, AS NEEDED.
- * DENOTES SIGNS THAT ARE UNIQUE TO MONTANA.

| | |
|---|--------------------|
| DETAILED DRAWING | |
| REFERENCE STANDARD SPEC. SECTION 618 | DWG. NO. 618-14 |
| TWO-LANE EQUIPMENT ENTRANCES | |
| EFFECTIVE: FEBRUARY 2005 | |
|  MONTANA DEPARTMENT OF TRANSPORTATION <i>-serving you with pride</i> | |

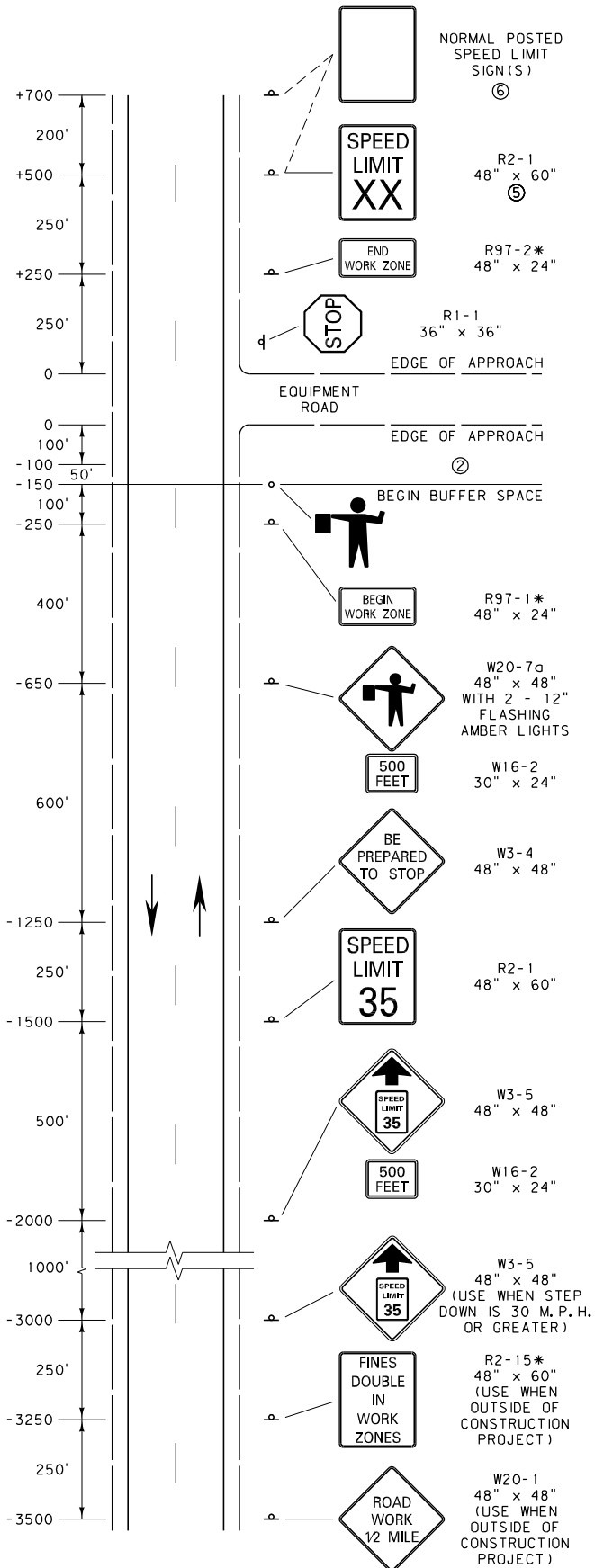

- NOTES:
- ① SET UP THIS SIGN LAYOUT IN EACH TRAFFIC DIRECTION, AS NEEDED.
 - ② THE BUFFER SPACE MAY BE INCREASED FOR DOWNGRADES AND OTHER CONDITIONS THAT AFFECT STOPPING DISTANCE.
 - ③ XX = SPEED DETERMINED BY THE ENGINEER.
 - ④ THE WORK ZONE REFERS TO THE AREA WHERE WORK IS ACTUALLY TAKING PLACE. WHEN THIS OCCURS OUTSIDE OF A CONSTRUCTION PROJECT INCLUDE THE W20-1 AND R2-15* SIGNS.
 - ⑤ POST THE END OF WORK ZONE SPEED LIMIT APPROPRIATE FOR ALL VEHICLES FOR THE REMAINDER OF THE CONSTRUCTION PROJECT BEFORE RESUMING TO NORMAL POSTED SPEED LIMITS AT THE END OF THE CONSTRUCTION PROJECT.
 - ⑥ WHEN OUTSIDE OF A CONSTRUCTION PROJECT, POST THE SPEED LIMIT CONSISTING OF ONE SIGN WHEN THE NORMAL POSTED SPEED LIMIT FOR ALL VEHICLES IS THE SAME. USE TWO SIGNS WHEN CAR, TRUCK AND NIGHTTIME SPEED LIMITS ARE DIFFERENT.
- * DENOTES SIGNS THAT ARE UNIQUE TO MONTANA.

EQUIPMENT ENTRANCE WITH FLAGGER

| | |
|---|-----------------|
| DETAILED DRAWING | |
| REFERENCE STANDARD SPEC. SECTION 618 | DWG. NO. 618-16 |
| TWO-LANE EQUIPMENT ENTRANCES | |
| EFFECTIVE: APRIL 2006 | |
|  MONTANA DEPARTMENT OF TRANSPORTATION <i>servicing you with pride</i> | |

NOTES:

- ① INCLUDE REGULATORY SIGNING ONLY IF THERE IS REASON TO RESTRICT SPEED. MODIFY REGULATORY SIGNS TO MATCH ADJACENT REGULATIONS.
 - ② SET UP THIS SIGN LAYOUT IN EACH TRAFFIC DIRECTION.
 - ③ PAVED DETOURS 24 FEET WIDE OR GREATER HAVE 4 INCH WHITE SHOULDER STRIPES AND APPROPRIATE CENTERLINE STRIPES.
 - ④ UNPAVED DETOURS MAY REQUIRE ADDITIONAL DELINEATION.
 - ⑤ USE ONLY POST MOUNTED SIGNS. DO NOT USE PORTABLE SIGN MOUNTS.
 - ⑥ PLACE PLASTIC DRUMS AT INTERVALS IN FEET OF NO MORE THAN ONE TIMES THE SPEED LIMIT IN M.P.H. OR AS DIRECTED BY THE ENGINEER FOR SPEEDS LESS THAN 35 M.P.H.
 - ⑦ XX = SPEED DETERMINED BY THE DETOUR DESIGN SPEED OR THE ENGINEER.
 - ⑧ THE WORK ZONE REFERS TO THE AREA WITHIN THE CONSTRUCTION PROJECT WHERE WORK IS ACTUALLY TAKING PLACE.
 - ⑨ USE MATERIALS FOR BARRICADE FRAMEWORK AND ASSEMBLY, INCLUDING ANY SIGNS AND MEANS OF ATTACHMENT, THAT MEET THE REQUIREMENTS FOR NCHRP 350 FOR WORK ZONE DEVICES. ALTERNATIVELY, SIGNS ON BARRICADES MAY BE MOUNTED DIRECTLY BEHIND BARRICADES ON SEPARATE SIGN SUPPORTS.
 - ⑩ POST THE END OF WORK ZONE SPEED LIMIT APPROPRIATE FOR ALL VEHICLES FOR THE REMAINDER OF THE CONSTRUCTION PROJECT BEFORE RESUMING TO NORMAL POSTED SPEED LIMITS AT THE END OF THE CONSTRUCTION PROJECT.
- * DENOTES SIGNS THAT ARE UNIQUE TO MONTANA.

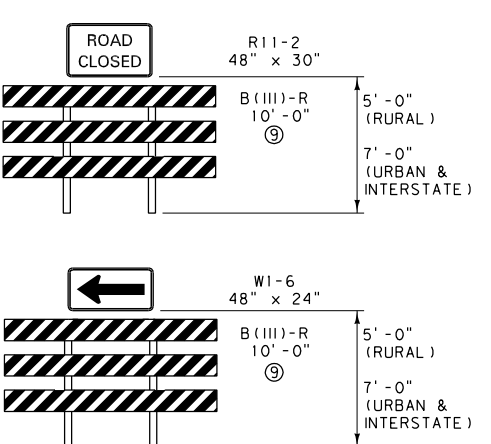
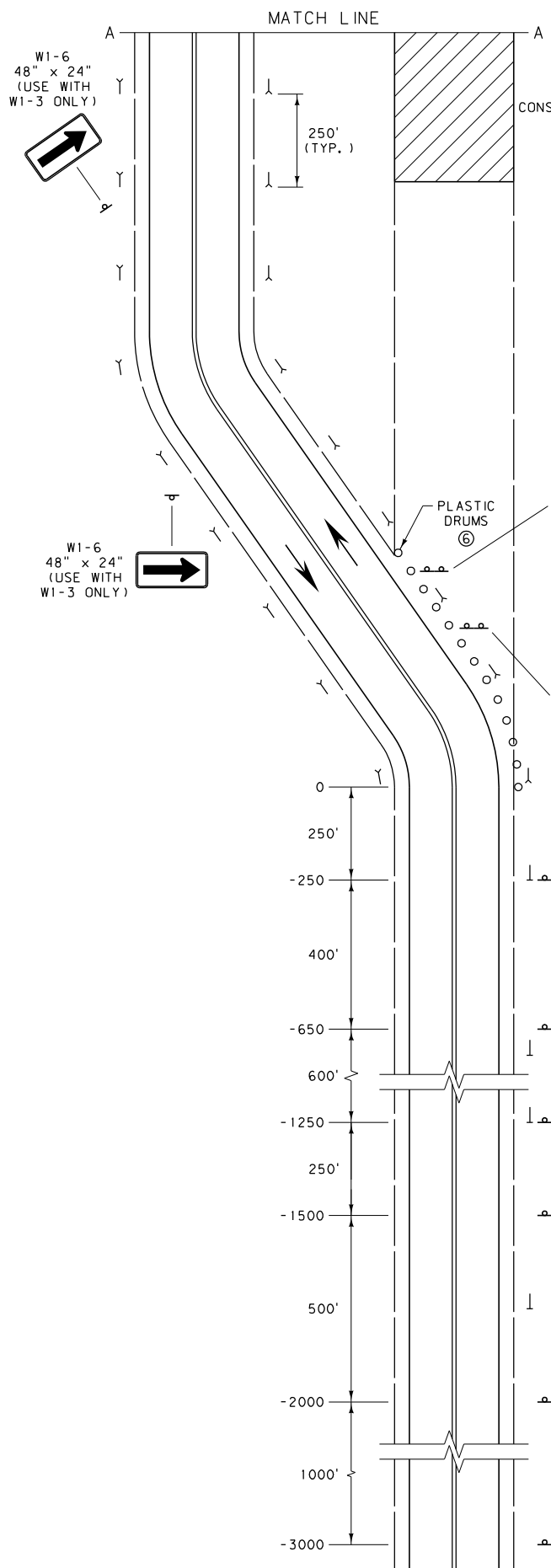
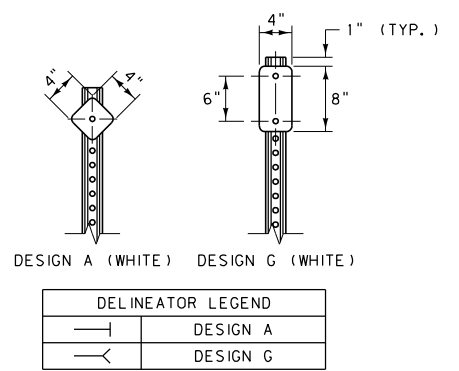

- Ⓐ USE THE W1-4 AND W1-3 SIGNS WHEN THE TANGENT DISTANCE ALONG THE DETOUR IS MORE THAN 600'.
- Ⓑ USE W1-3 SIGNS ONLY WHEN THE DESIGN SPEED OF THE CURVES IS 30 M.P.H. OR LESS.
- Ⓒ INCLUDE THE BEGIN AND END WORK ZONE SIGNS IF A WORK ZONE OCCURS EXCLUSIVELY ON THE DETOUR.

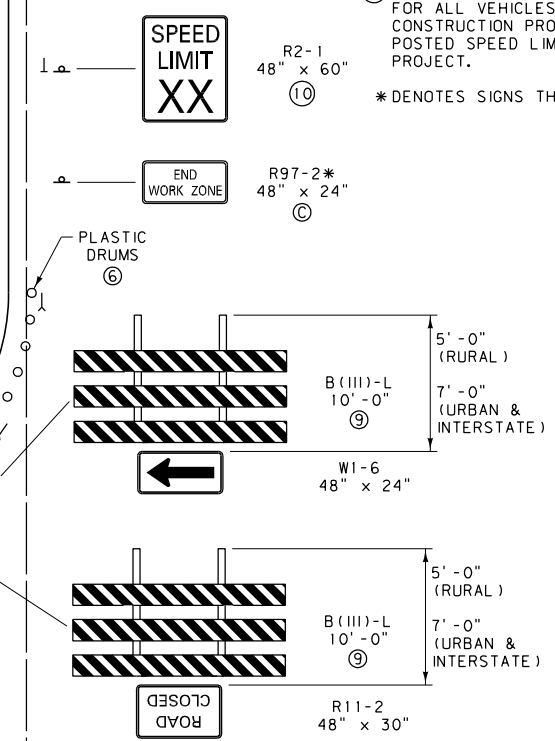
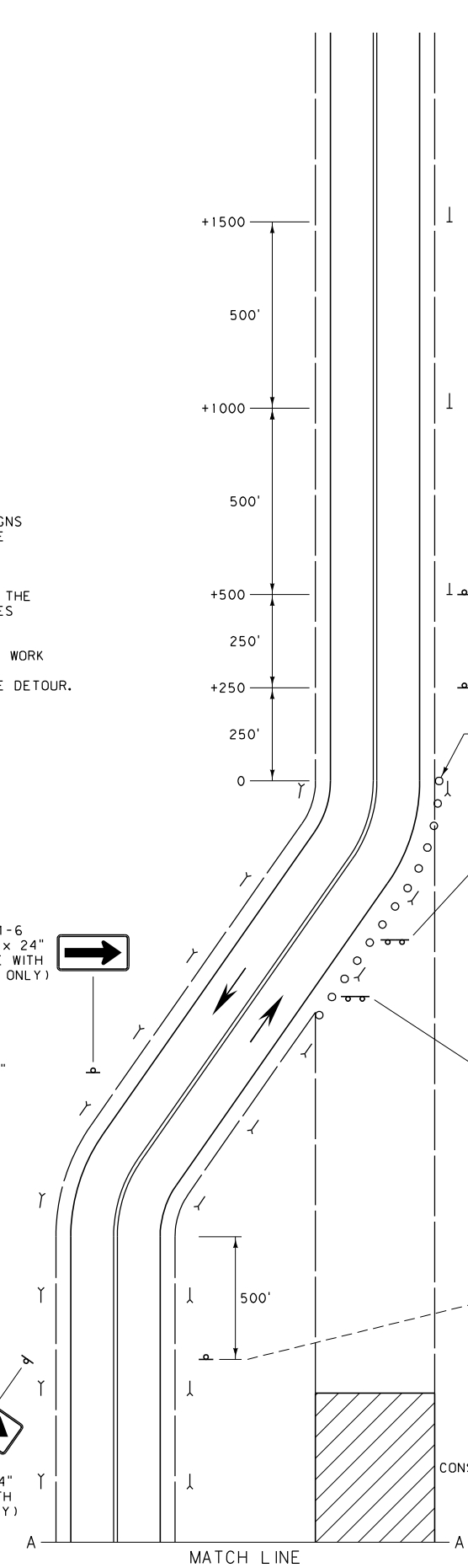

| | |
|--------------------------------------|--------------------------------------|
| DETAILED DRAWING | |
| REFERENCE STANDARD SPEC. SECTION 618 | DWG. NO. 618-18 |
| TWO-LANE CONSTRUCTION PROJECT DETOUR | |
| EFFECTIVE: APRIL 2006 | |
| | MONTANA DEPARTMENT OF TRANSPORTATION |

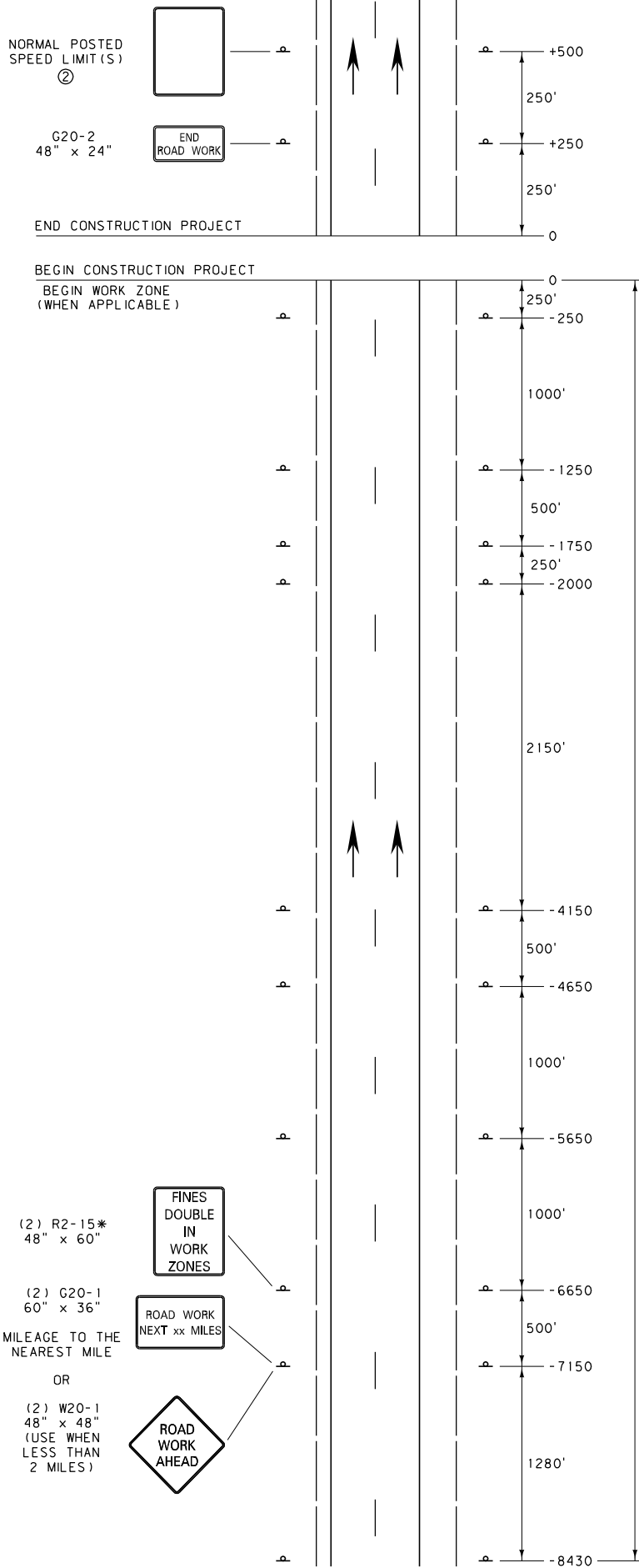

NOTES:

- ① THIS SIGN LAYOUT IS INTENDED TO BE A PERMANENT INSTALLATION FOR THE DURATION OF THE CONSTRUCTION PROJECT, AS APPROVED BY THE ENGINEER. COVER OR REMOVE SIGNS WHEN NOT IN USE, INCLUDING SPEED LIMIT SIGNS NOT WARRANTED. REMOVE ANY SIGN SUPPORTS IF THEY WILL NOT BE NEEDED WITHIN 90 DAYS.
- ② POST THE END OF CONSTRUCTION PROJECT SPEED LIMIT CONSISTING OF ONE LIMIT WHEN THE NORMAL POSTED SPEED LIMIT FOR ALL VEHICLES IS THE SAME. WHEN CAR AND TRUCK SPEED LIMITS DIFFER, POST BOTH LIMITS ON A SINGLE SIGN.
- ③ INCLUDE REGULATORY SIGNING ONLY IF THE CONSTRUCTION PROJECT CONTAINS A WORK ZONE OR HAS ROADWAY CONDITIONS THAT WARRANT SPEED RESTRICTIONS. MODIFY REGULATORY SIGNS TO MATCH ADJACENT REGULATIONS.
- ④ THE WORK ZONE REFERS TO THE AREA WITHIN THE CONSTRUCTION PROJECT WHERE WORK IS ACTUALLY TAKING PLACE.
- ⑤ SET UP THIS SIGN LAYOUT IN EACH TRAFFIC DIRECTION.
- ⑥ IN ADDITION TO THE SIGNS SHOWN, INCLUDE THE APPROPRIATE FOUR-LANE WORK ZONE SIGNS (DTL. DWG. NO. 618-24) WHEN A WORK ZONE FALLS AT THE BEGIN OR END OF THE CONSTRUCTION PROJECT.
- ⑦ DIVIDED FOUR-LANE IS SHOWN. FOR UN-DIVIDED FOUR-LANE, PLACE SIGNS ON RIGHT SIDE ONLY.

* DENOTES SIGNS THAT ARE UNIQUE TO MONTANA.

FOUR-LANE WORK ZONE SIGN LAYOUT (WHEN APPLICABLE, SEE DTL. DWG. 618-24) ⑥

| | |
|---|---|
| DETAILED DRAWING | |
| REFERENCE STANDARD SPEC. SECTION 618 | DWG. NO. 618-20 |
| DIVIDED FOUR-LANE CONSTRUCTION PROJECT | |
| EFFECTIVE: APRIL 2006 | |
|  | MONTANA DEPARTMENT OF TRANSPORTATION <i>servicing you with pride</i> |

MATCH LINE FROM
DTL. DWG. NO. 618-30

NOTES:

- ① SPACE CHANNELIZING DEVICES ON TANGENTS AT INTERVALS IN FEET OF NO MORE THAN TWO TIMES THE SPEED LIMIT IN M.P.H. AND ON ALL TAPER SECTIONS AT INTERVALS IN FEET OF NO MORE THAN ONE TIMES THE SPEED LIMIT IN M.P.H. FOR SPEED LIMITS LESS THAN 35 M.P.H. SPACE CHANNELIZING DEVICES AS DIRECTED BY THE ENGINEER.
- ② OBLITERATE ALL PAVEMENT MARKINGS THAT CONFLICT AT ANY TIME DURING OR AFTER MEDIAN CROSSING USE.
- ③ INDICATED SPACINGS ARE INTENDED TO BE A MAXIMUM AND MAY BE REDUCED IF CONDITIONS WARRANT.
- ④ USE MATERIALS FOR BARRICADE FRAMEWORK AND ASSEMBLY, INCLUDING ANY SIGNS AND MEANS OF ATTACHMENT, THAT MEET THE REQUIREMENTS FOR NCHRP 350 FOR WORK ZONE DEVICES. ALTERNATIVELY, SIGNS ON BARRICADES MAY BE MOUNTED DIRECTLY BEHIND BARRICADES ON SEPARATE SIGN SUPPORTS.

FLEXIBLE GLUE
DOWN GUIDE
POSTS SPACED
AT HALF NORMAL
SPACING

R3-2
36" x 36"



100'

1000'

500'
MERGING
LANE

500'
ACCELERATION
LANE

WHITE

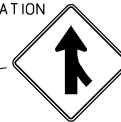

W4-1
48" x 48"

250'



R5-1
36" x 36"

250'

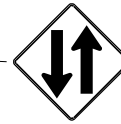

W6-3
48" x 48"

W4-1
48" x 48"



10:1 TAPER
(DESIRABLE)
8:1 TAPER
(MINIMUM)



R5-1a
36" x 24"
(ANGLE 20° TOWARDS
CROSS-OVER LANE)

YELLOW



R11-2
48" x 30"

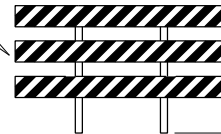

B(III)-R
10'-0"
④
5'-0"
(RURAL)
7'-0"
(URBAN &
INTERSTATE)

R3-2
36" x 36"



250'



W6-3
48" x 48"

W16-9P
30" x 18"



W20-1
48" x 48"

500'

LEGEND

- OBLITERATE CONFLICTING PAVEMENT MARKINGS AND FILL ANY EXISTING RUMBLE STRIPS WITH PMS
- PLASTIC DRUMS (SEE NOTES FOR SPACING)
- - - - - RAISED RIGID PAVEMENT MARKERS TYPE I OR II AT 5' SPACING
- ==== DOUBLE YELLOW PAINT OR DOUBLE PLASTIC PAVEMENT MARKING TABS AT 5' SPACING
- FLEXIBLE GLUE-DOWN GUIDE POSTS ON TWO-LANE (SEE NOTES FOR SPACING EXCEPT AS SHOWN)

DETAILED DRAWING

| | |
|--------------------------------------|-----------------|
| REFERENCE STANDARD SPEC. SECTION 618 | DWG. NO. 618-21 |
|--------------------------------------|-----------------|

TEMPORARY
ENTRANCE RAMP
MEDIAN CROSSING

EFFECTIVE: APRIL 2006

LEGEND

- OBLITERATE CONFLICTING PAVEMENT MARKINGS AND FILL ANY EXISTING RUMBLE STRIPS WITH PMS
- PLASTIC DRUMS (SEE NOTES FOR SPACING)
- - - - - RAISED RIGID PAVEMENT MARKERS TYPE I OR II AT 5' SPACING
- ==== DOUBLE YELLOW PAINT OR DOUBLE PLASTIC PAVEMENT MARKING TABS AT 5' SPACING
- FLEXIBLE GLUE-DOWN GUIDE POSTS ON TWO-LANE (SEE NOTES FOR SPACING EXCEPT AS SHOWN)

E5-1
60" x 48"



R3-2
36" x 36"



FLEXIBLE GLUE
DOWN GUIDE
POSTS SPACED
AT HALF NORMAL
SPACING

W6-3
48" x 48"



E7-1
72" x 36"

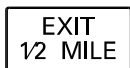

YELLOW

WHITE

10: 1 TAPER
(DESIRABLE)

8: 1 TAPER
(MINIMUM)

NOTES:

- ① SPACE CHANNELIZING DEVICES ON TANGENTS AT INTERVALS IN FEET OF NO MORE THAN TWO TIMES THE SPEED LIMIT IN M. P. H. AND ON ALL TAPER SECTIONS AT INTERVALS IN FEET OF NO MORE THAN ONE TIMES THE SPEED LIMIT IN M. P. H. FOR SPEED LIMITS LESS THAN 35 M. P. H. SPACE CHANNELIZING DEVICES AS DIRECTED BY THE ENGINEER.
- ② OBLITERATE ALL PAVEMENT MARKINGS THAT CONFLICT AT ANY TIME DURING OR AFTER MEDIAN CROSSING USE.
- ③ INDICATED SPACINGS ARE INTENDED TO BE A MAXIMUM AND MAY BE REDUCED IF CONDITIONS WARRANT.
- ④ PROVIDE ADDITIONAL SIGNING FOR EXIT DESTINATION WHEN EXIT DELINEATION IS NOT VISIBLE.
- ⑤ USE MATERIALS FOR BARRICADE FRAMEWORK AND ASSEMBLY, INCLUDING ANY SIGNS AND MEANS OF ATTACHMENT, THAT MEET THE REQUIREMENTS FOR NCHRP 350 FOR WORK ZONE DEVICES. ALTERNATIVELY, SIGNS ON BARRICADES MAY BE MOUNTED DIRECTLY BEHIND BARRICADES ON SEPARATE SIGN SUPPORTS.

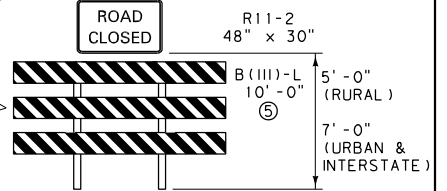

DETAILED DRAWING

| | |
|--------------------------------------|-----------------|
| REFERENCE STANDARD SPEC. SECTION 618 | DWG. NO. 618-22 |
|--------------------------------------|-----------------|

TEMPORARY
EXIT RAMP
MEDIAN CROSSING

EFFECTIVE: APRIL 2006

NOTE:
THIS SEQUENCE OF SIGNS IS IDENTICAL FOR BOTH WORK ZONES SHOWN ON THIS DETAIL.

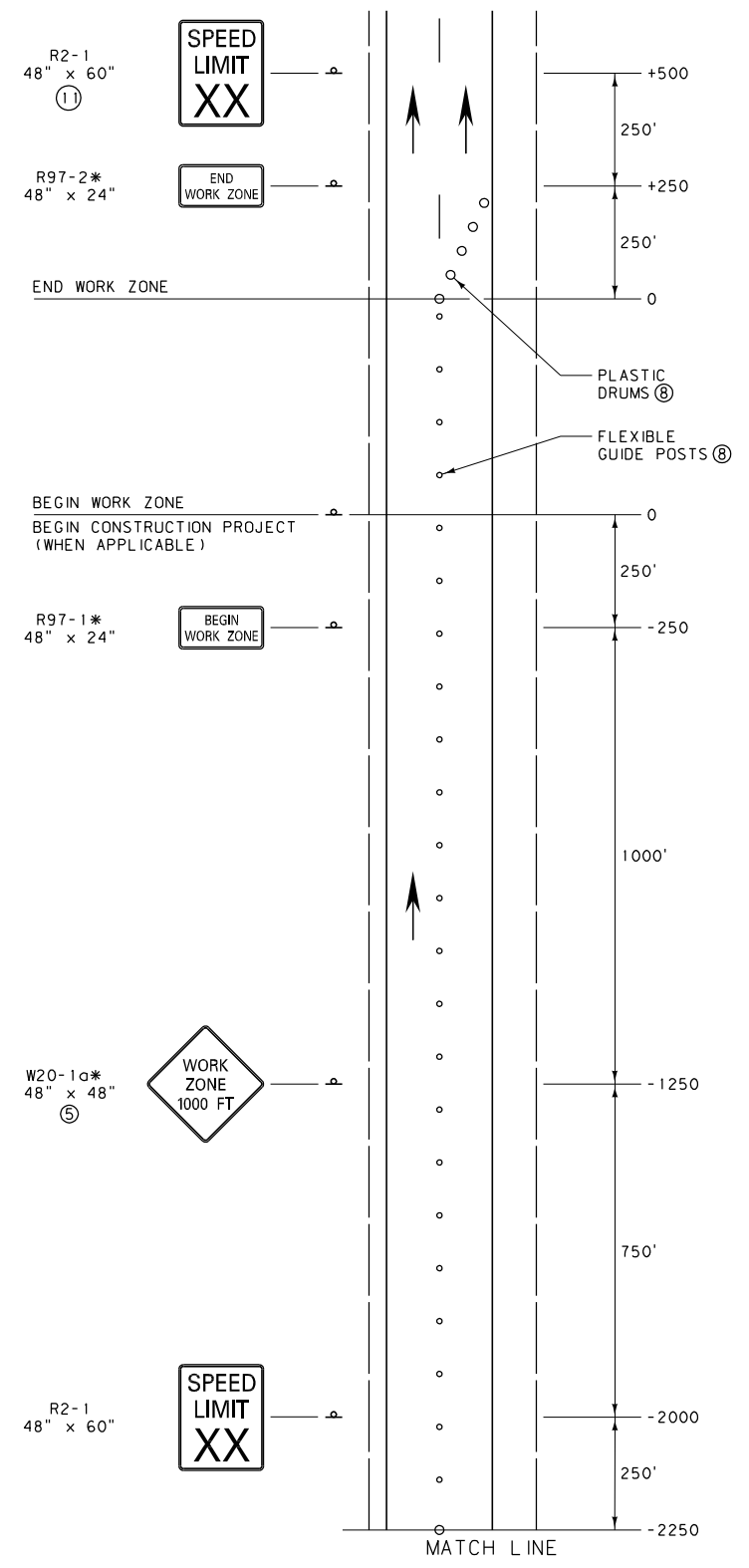
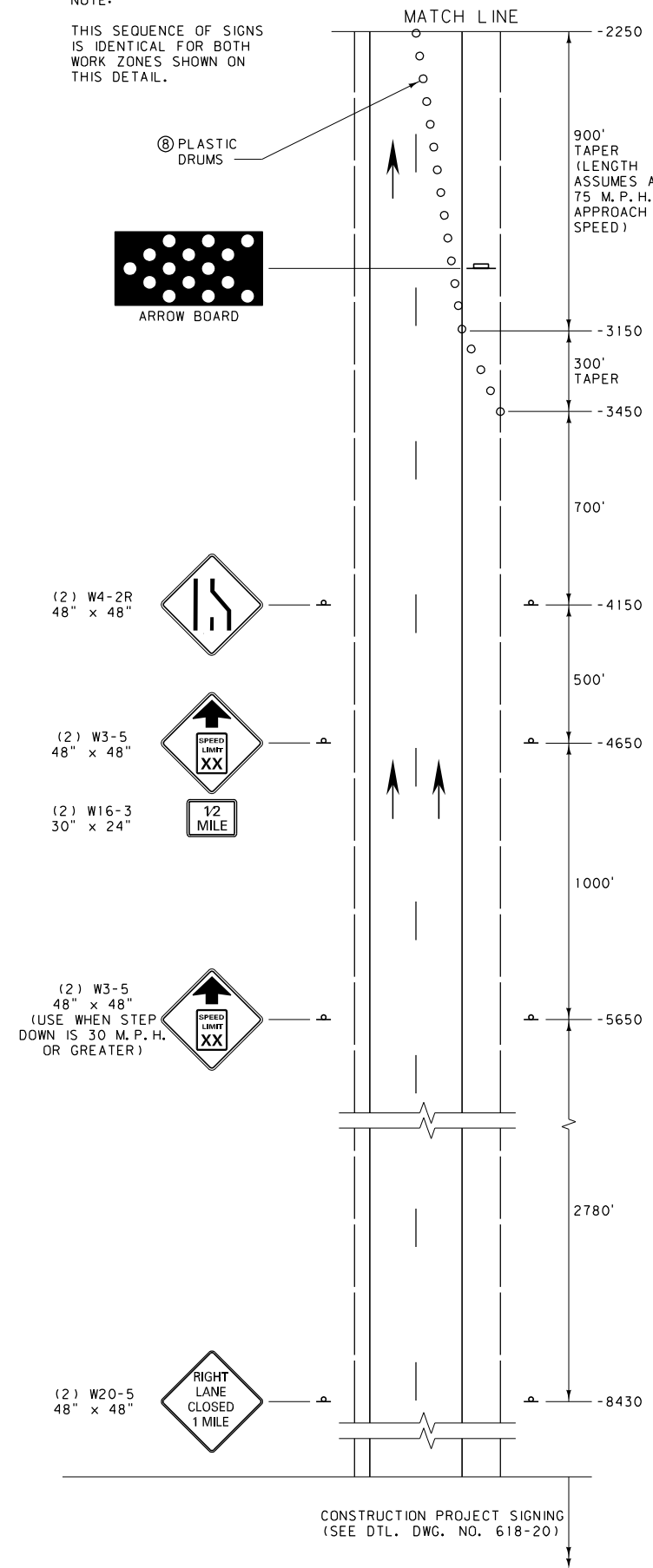

WORK ZONE WITH NO FLAGGER

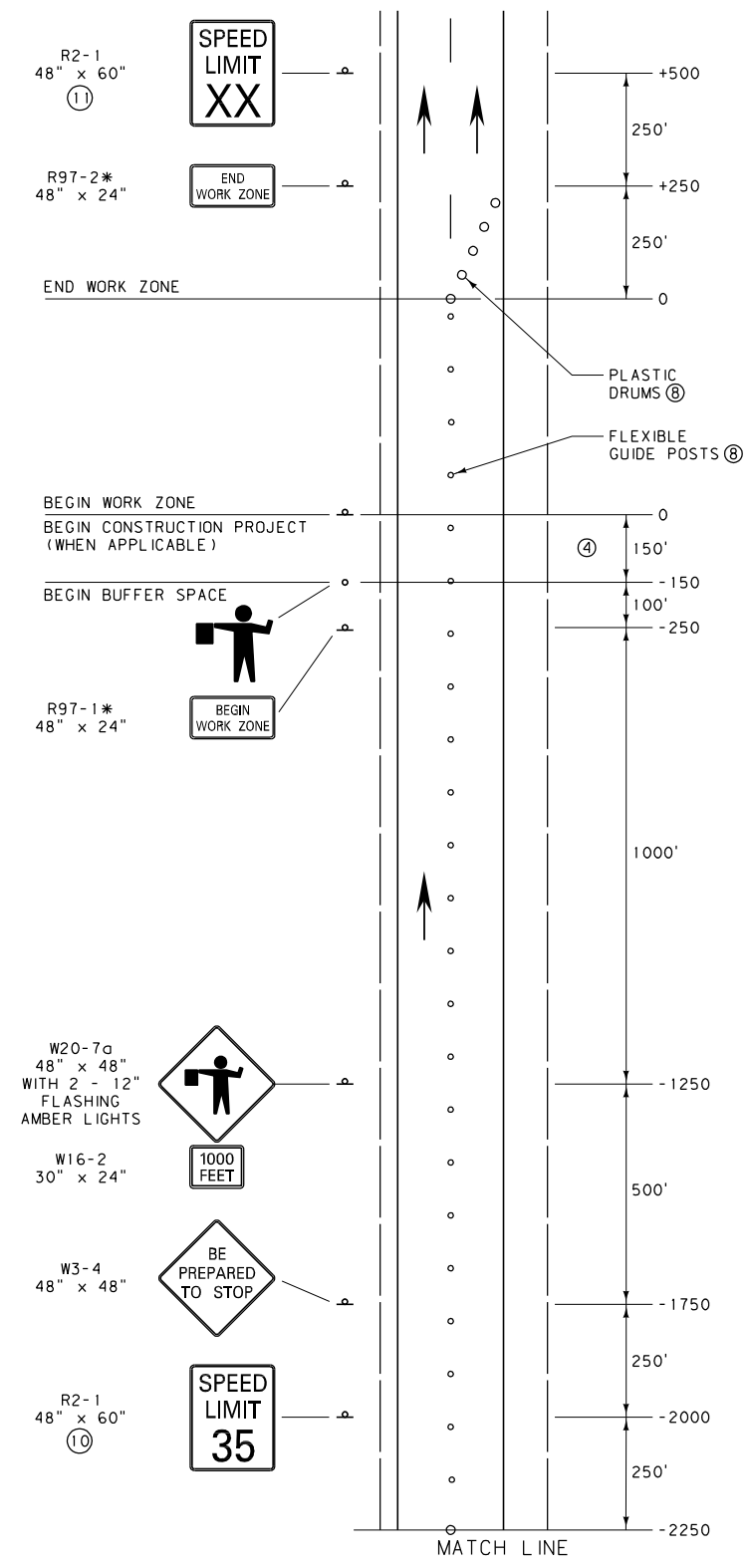

WORK ZONE WITH FLAGGER

- NOTES:
- ① THESE SIGN LAYOUTS WORK IN CONJUNCTION WITH THE PERMANENT LAYOUT ILLUSTRATED ON DTL. DWG. NO. 618-20 FOR WORK ZONES LOCATED AT THE BEGIN AND END OF THE CONSTRUCTION PROJECT.
 - ② INCLUDE REGULATORY SIGNING ONLY IF THERE IS REASON TO RESTRICT SPEED WITHIN THE WORK ZONE. MODIFY REGULATORY SIGNS TO MATCH ADJACENT REGULATIONS.
 - ③ THE WORK ZONE REFERS TO THE AREA WITHIN THE CONSTRUCTION PROJECT WHERE WORK IS ACTUALLY TAKING PLACE.
 - ④ THE BUFFER SPACE MAY BE INCREASED FOR DOWNGRADES AND OTHER CONDITIONS THAT AFFECT STOPPING DISTANCE.
 - ⑤ USE MORE SPECIFIC SIGNS, WHERE APPLICABLE, SUCH AS W8-3 "PAVEMENT ENDS."
 - ⑥ XX = SPEED DETERMINED BY THE ENGINEER.
 - ⑦ PROVIDE A SECOND FLAGGER WHEN REQUIRED BY STANDARD SPECIFICATIONS, SECTION 618.
 - ⑧ SPACE FLEXIBLE GUIDE POSTS ON TANGENTS AT INTERVALS IN FEET OF NO MORE THAN TWO TIMES THE SPEED LIMIT IN M.P.H. SPACE PLASTIC DRUMS IN ALL TAPER SECTIONS AT INTERVALS IN FEET OF NO MORE THAN ONE TIMES THE SPEED LIMIT IN M.P.H. FOR SPEED LIMITS LESS THAN 35 M.P.H., SPACE CHANNELIZING DEVICES AS DIRECTED BY THE ENGINEER.
 - ⑨ WHEN PORTABLE SIGNS ARE USED, PLACE AS DIRECTED BY THE ENGINEER.
 - ⑩ IF FLAGGER IS MORE THAN ONE MILE FROM THE LANE CLOSURE, INCLUDE W3-5 SIGNS, AS REQUIRED.
 - ⑪ POST THE END OF WORK ZONE SPEED LIMIT APPROPRIATE FOR ALL VEHICLES FOR THE REMAINDER OF THE CONSTRUCTION PROJECT BEFORE RESUMING TO NORMAL POSTED SPEED LIMITS AT THE END OF THE CONSTRUCTION PROJECT.

* DENOTES SIGNS THAT ARE UNIQUE TO MONTANA.

| | |
|---|--------------------------------------|
| DETAILED DRAWING | |
| REFERENCE STANDARD SPEC. SECTION 618 | DWG. NO. 618-24 |
| DIVIDED FOUR-LANE CONSTRUCTION PROJECT WORK ZONES | |
| EFFECTIVE: APRIL 2006 | |
| | MONTANA DEPARTMENT OF TRANSPORTATION |

NOTE:
THIS SEQUENCE OF SIGNS
IS IDENTICAL FOR BOTH
WORK ZONES SHOWN ON
THIS DETAIL.

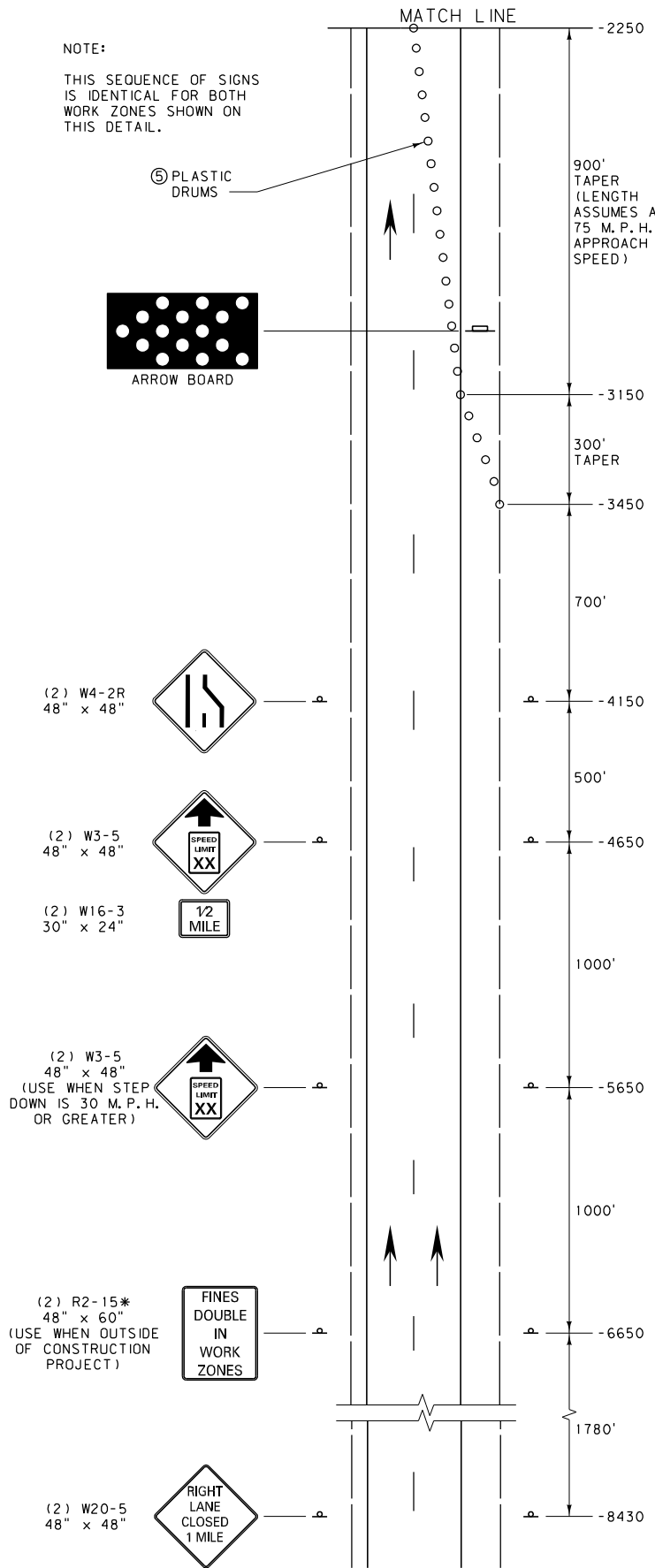

NORMAL POSTED SPEED LIMIT(S)

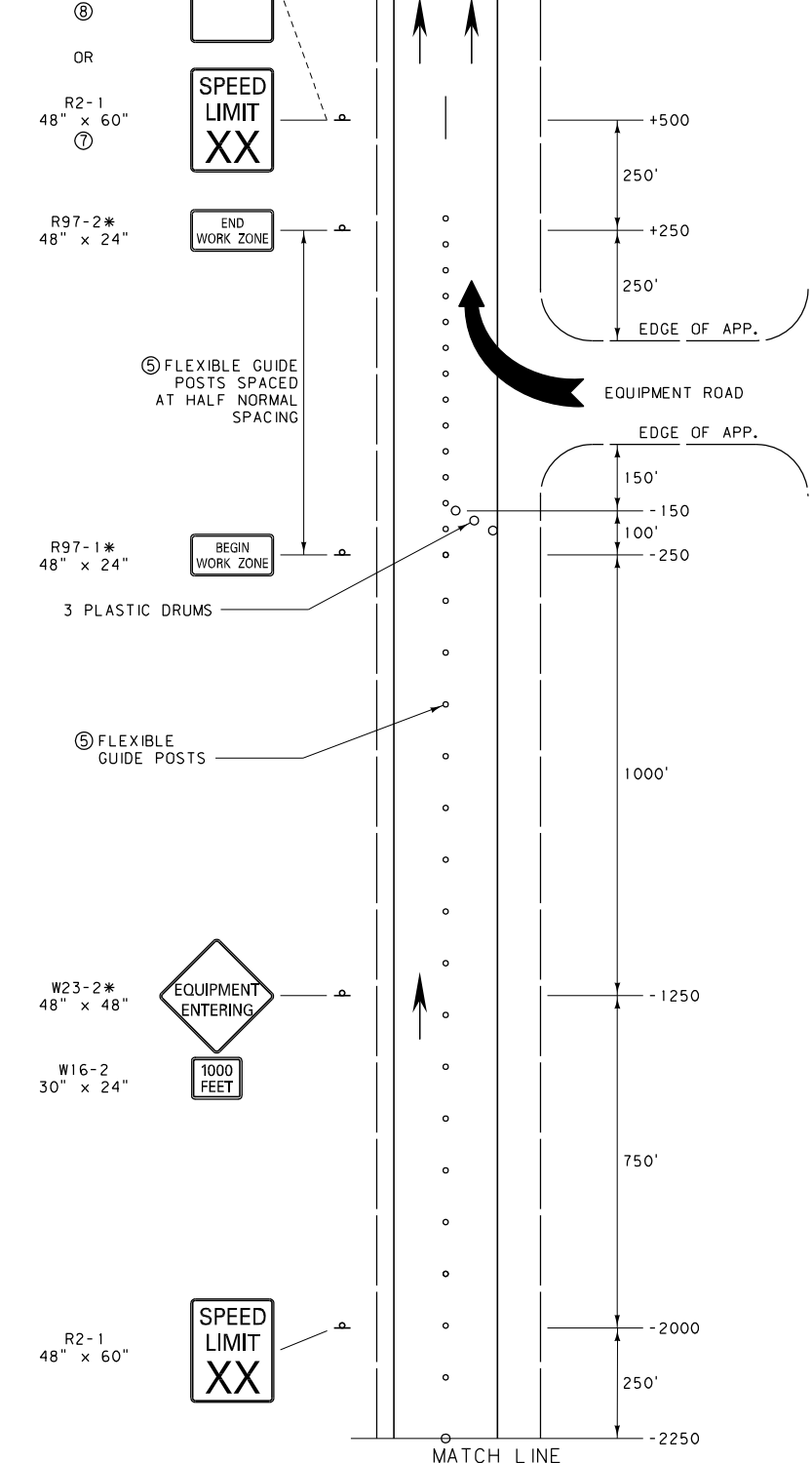

NORMAL POSTED SPEED LIMIT(S)

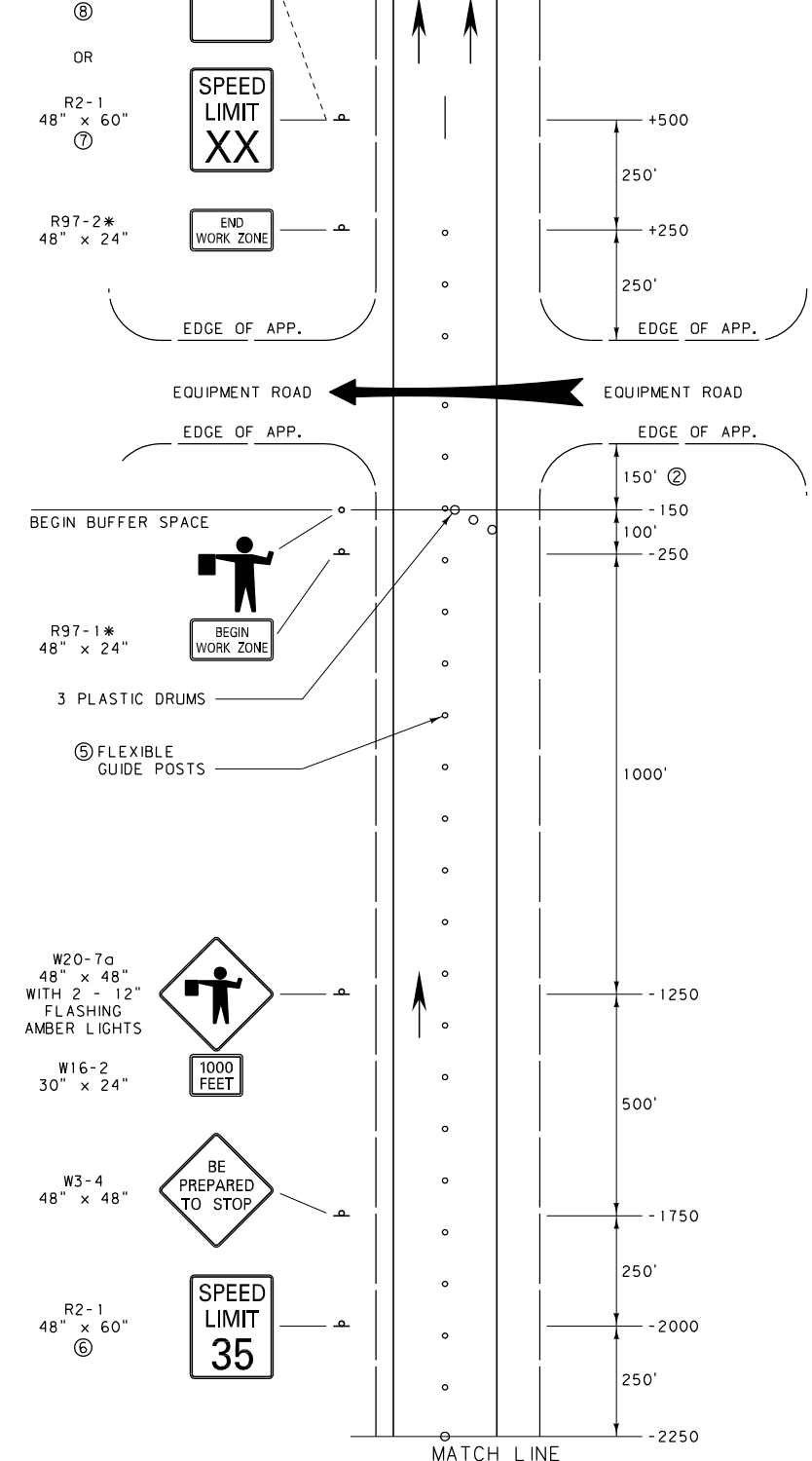

- NOTES:
- INCLUDE REGULATORY SIGNING ONLY IF THERE IS REASON TO RESTRICT SPEED WITHIN THE WORK ZONE. MODIFY REGULATORY SIGNS TO MATCH ADJACENT REGULATIONS.
 - THE BUFFER SPACE MAY BE INCREASED FOR DOWNGRADES AND OTHER CONDITIONS THAT AFFECT STOPPING DISTANCE.
 - XX = SPEED DETERMINED BY THE ENGINEER.
 - THE WORK ZONE REFERS TO THE AREA WHERE WORK IS ACTUALLY TAKING PLACE. WHEN THIS OCCURS OUTSIDE OF A CONSTRUCTION PROJECT, INCLUDE THE R2-15* SIGN.
 - SPACE FLEXIBLE GUIDE POSTS ON TANGENTS AT INTERVALS IN FEET OF NO MORE THAN TWO TIMES THE SPEED LIMIT IN M.P.H. SPACE PLASTIC DRUMS IN ALL TAPER SECTIONS AT INTERVALS IN FEET OF NO MORE THAN ONE TIMES THE SPEED LIMIT IN M.P.H. FOR SPEED LIMITS LESS THAN 35 M.P.H., SPACE CHANNELIZING DEVICES AS DIRECTED BY THE ENGINEER.
 - IF FLAGGER IS MORE THAN ONE MILE FROM THE LANE CLOSURE, INCLUDE W3-5 SIGNS, AS REQUIRED.
 - POST THE END OF WORK ZONE SPEED LIMIT APPROPRIATE FOR ALL VEHICLES FOR THE REMAINDER OF THE CONSTRUCTION PROJECT BEFORE RESUMING TO NORMAL POSTED SPEED LIMITS AT THE END OF THE CONSTRUCTION PROJECT.
 - WHEN OUTSIDE OF A CONSTRUCTION PROJECT, POST THE SPEED LIMIT CONSISTING OF ONE LIMIT WHEN THE NORMAL POSTED SPEED LIMIT FOR ALL VEHICLES IS THE SAME. WHEN CAR AND TRUCK SPEED LIMITS DIFFER, POST BOTH LIMITS ON A SINGLE SIGN.
- * DENOTES SIGNS THAT ARE UNIQUE TO MONTANA.

DETAILED DRAWING

| | |
|---|-----------------|
| REFERENCE STANDARD SPEC. SECTION 618 | DWG. NO. 618-27 |
| DIVIDED FOUR-LANE EQUIPMENT ENTRANCES | |
| EFFECTIVE: APRIL 2006 | |
|  MONTANA DEPARTMENT OF TRANSPORTATION <i>servicing you with pride</i> | |

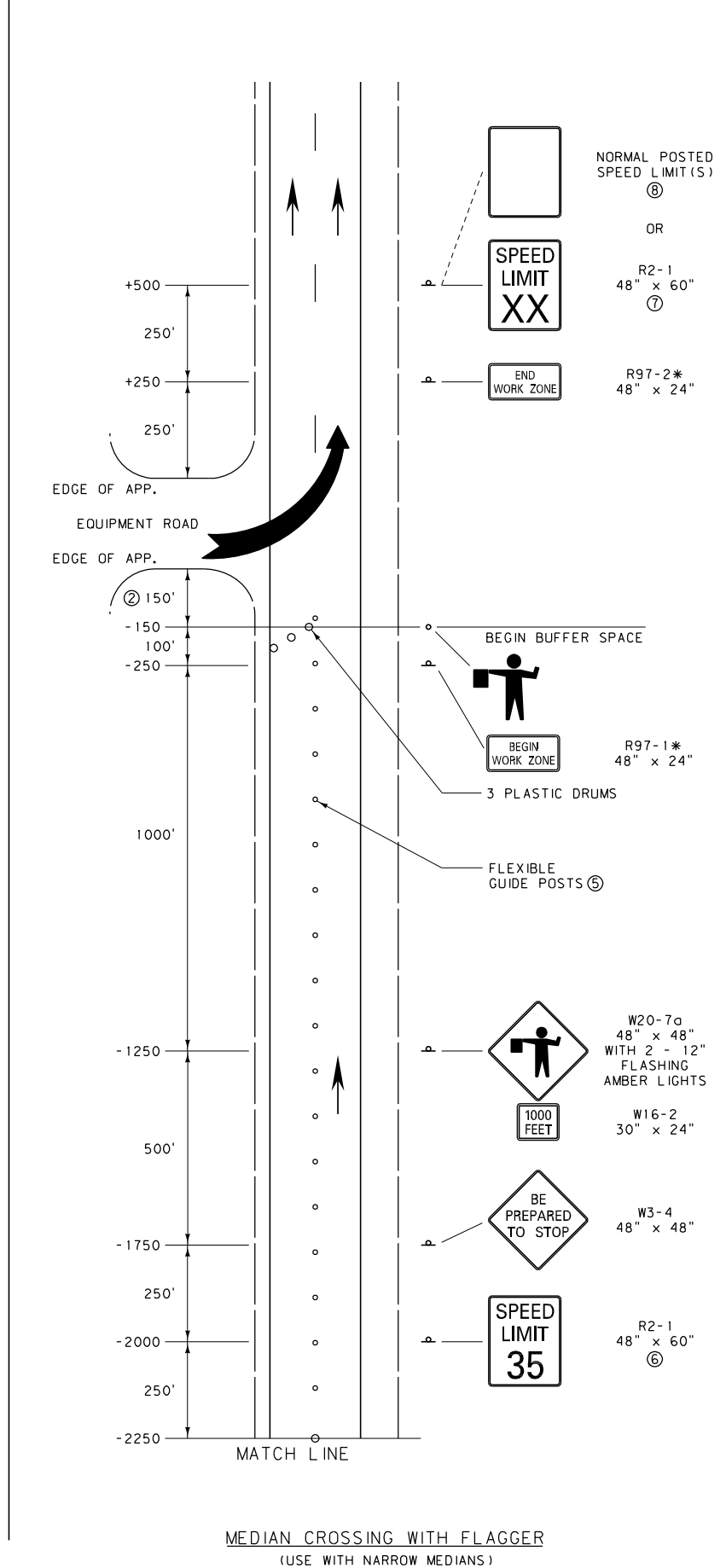
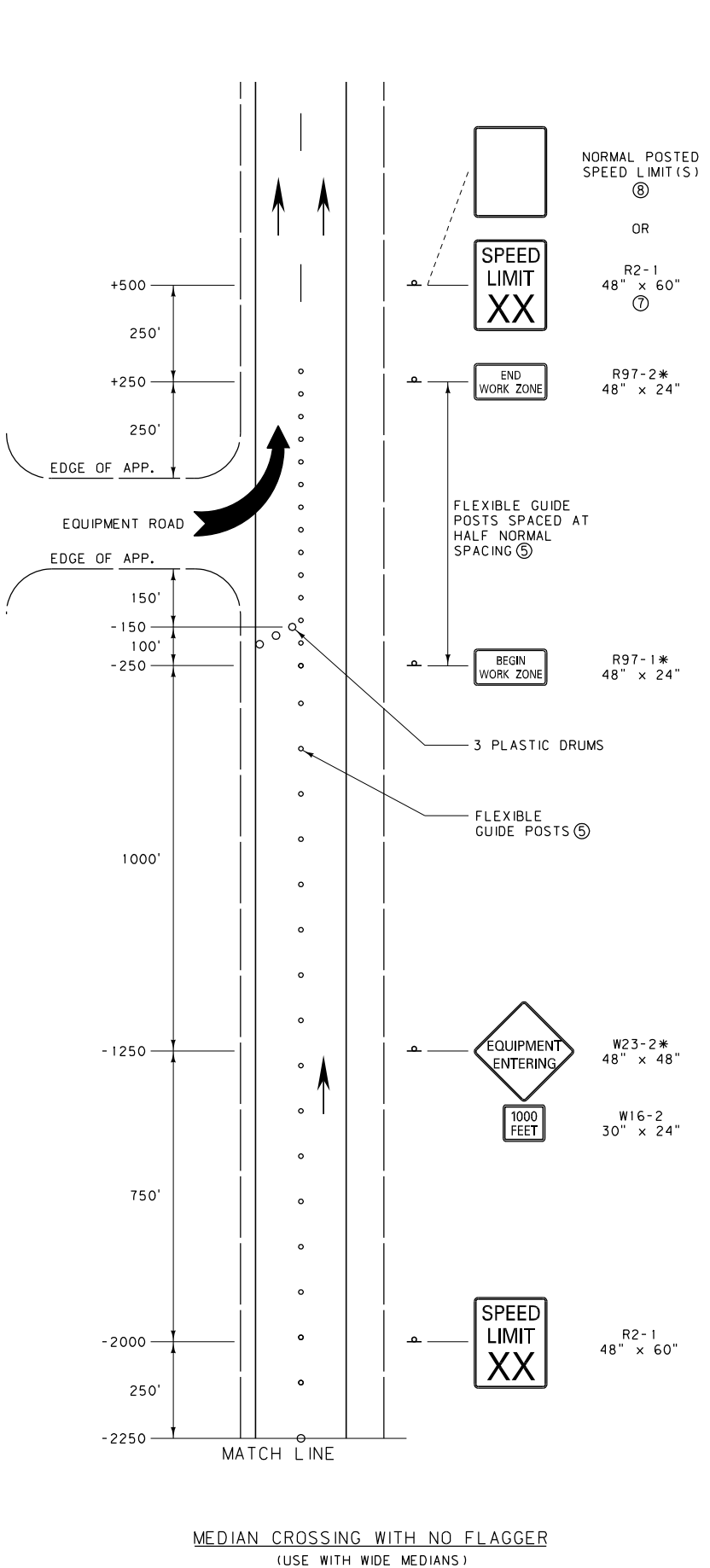
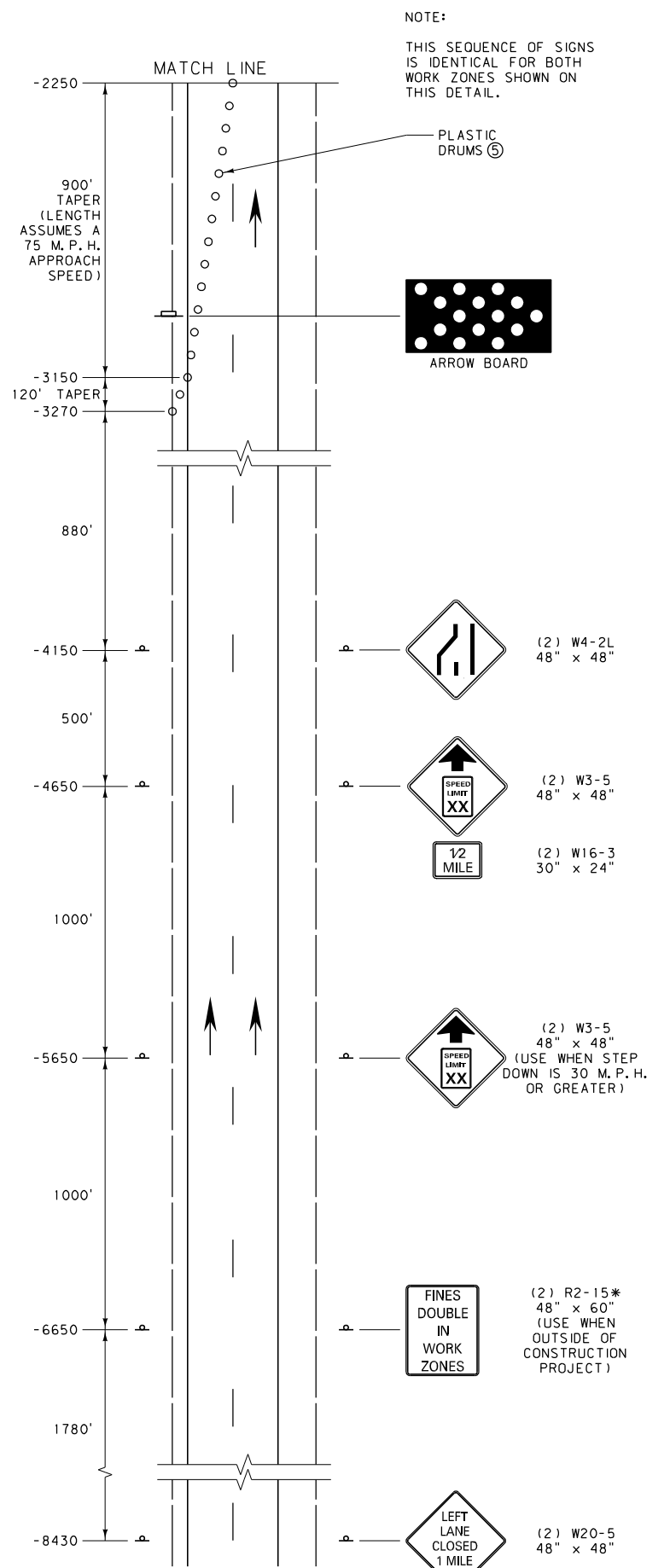

- NOTES:
- ① INCLUDE REGULATORY SIGNING ONLY IF THERE IS REASON TO RESTRICT SPEED WITHIN THE WORK ZONE. MODIFY REGULATORY SIGNS TO MATCH ADJACENT REGULATIONS.
 - ② THE BUFFER SPACE MAY BE INCREASED FOR DOWNGRADES AND OTHER CONDITIONS THAT AFFECT STOPPING DISTANCE.
 - ③ XX = SPEED DETERMINED BY THE ENGINEER.
 - ④ THE WORK ZONE REFERS TO THE AREA WHERE WORK IS ACTUALLY TAKING PLACE. WHEN THIS OCCURS OUTSIDE OF A CONSTRUCTION PROJECT, INCLUDE THE W20-1 AND R2-15* SIGNS.
 - ⑤ SPACE FLEXIBLE GUIDE POSTS ON TANGENTS AT INTERVALS IN FEET OF NO MORE THAN TWO TIMES THE SPEED LIMIT IN M.P.H. SPACE PLASTIC DRUMS IN ALL TAPER SECTIONS AT INTERVALS IN FEET OF NO MORE THAN ONE TIMES THE SPEED LIMIT IN M.P.H. FOR SPEED LIMITS LESS THAN 35 M.P.H., SPACE CHANNELIZING DEVICES AS DIRECTED BY THE ENGINEER.
 - ⑥ IF FLAGGER IS MORE THAN ONE MILE FROM THE LANE CLOSURE, INCLUDE W3-5 SIGNS, AS REQUIRED.
 - ⑦ POST THE END OF WORK ZONE SPEED LIMIT APPROPRIATE FOR ALL VEHICLES FOR THE REMAINDER OF THE CONSTRUCTION PROJECT BEFORE RESUMING TO NORMAL POSTED SPEED LIMITS AT THE END OF THE CONSTRUCTION PROJECT.
 - ⑧ WHEN OUTSIDE OF A CONSTRUCTION PROJECT, POST THE SPEED LIMIT CONSISTING OF ONE LIMIT WHEN THE NORMAL POSTED SPEED LIMIT FOR ALL VEHICLES IS THE SAME. WHEN CAR AND TRUCK SPEED LIMITS DIFFER, POST BOTH LIMITS ON A SINGLE SIGN.
- * DENOTES SIGNS THAT ARE UNIQUE TO MONTANA.

DETAILED DRAWING

| | |
|--|-----------------|
| REFERENCE STANDARD SPEC. SECTION 618 | DWG. NO. 618-28 |
| DIVIDED FOUR-LANE MEDIAN CROSSINGS | |
| EFFECTIVE: APRIL 2006 | |
|  MONTANA DEPARTMENT OF TRANSPORTATION | |

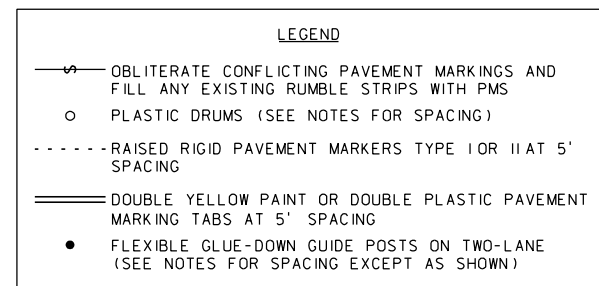
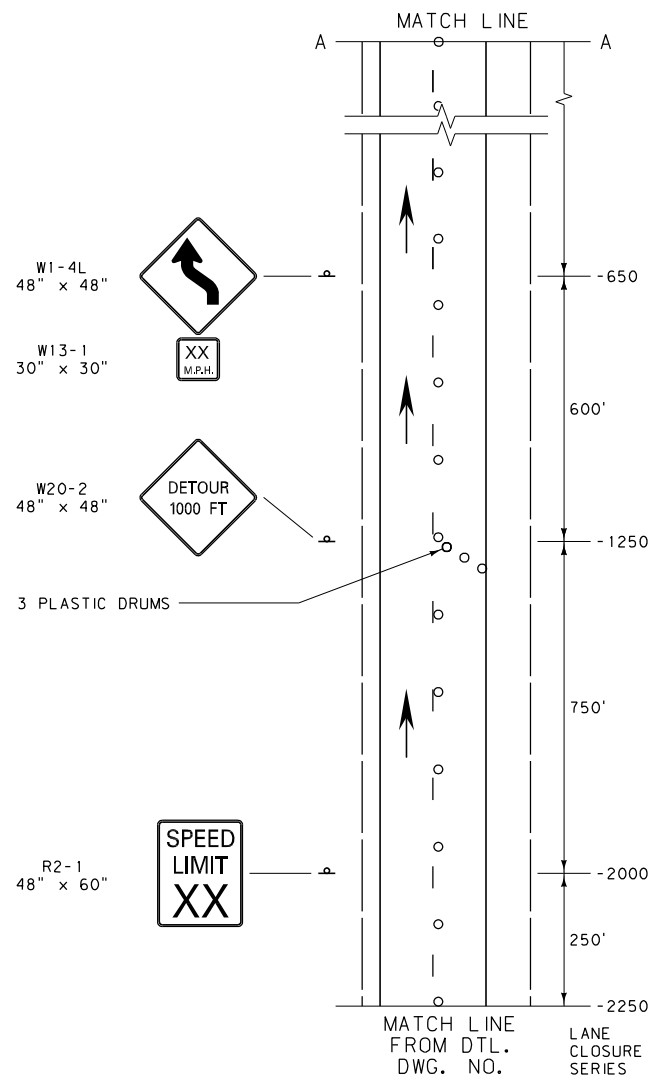

- NOTES:**
- ① INCLUDE REGULATORY SIGNING ONLY AS REQUIRED. MODIFY REGULATORY SIGNS TO MATCH ADJACENT REGULATIONS.
 - ② THE WORK ZONE REFERS TO THE AREA WITHIN THE CONSTRUCTION PROJECT WHERE WORK IS ACTUALLY TAKING PLACE.
 - ③ INDICATED SPACINGS ARE INTENDED TO BE A MAXIMUM AND MAY BE REDUCED IF CONDITIONS WARRANT.
 - ④ XX = SPEED DETERMINED BY THE MEDIAN CROSSING DESIGN SPEED OR THE ENGINEER.
 - ⑤ SPACE CHANNELIZING DEVICES ON TANGENTS AT INTERVALS IN FEET OF NO MORE THAN TWO TIMES THE SPEED LIMIT IN M.P.H. AND ON ALL TAPER SECTIONS AT INTERVALS IN FEET OF NO MORE THAN ONE TIMES THE SPEED LIMIT IN M.P.H. FOR SPEED LIMITS LESS THAN 35 M.P.H., SPACE CHANNELIZING DEVICES AS DIRECTED BY THE ENGINEER.
 - ⑥ OBLITERATE ALL PAVEMENT MARKINGS THAT CONFLICT AT ANY TIME DURING OR AFTER MEDIAN CROSSING USE.
 - ⑦ USE MATERIALS FOR BARRICADE FRAMEWORK AND ASSEMBLY, INCLUDING ANY SIGNS AND MEANS OF ATTACHMENT, THAT MEET THE REQUIREMENTS FOR NCHRP 350 FOR WORK ZONE DEVICES. ALTERNATIVELY, SIGNS ON BARRICADES MAY BE MOUNTED DIRECTLY BEHIND BARRICADES ON SEPARATE SIGN SUPPORTS.

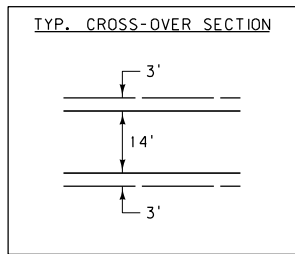
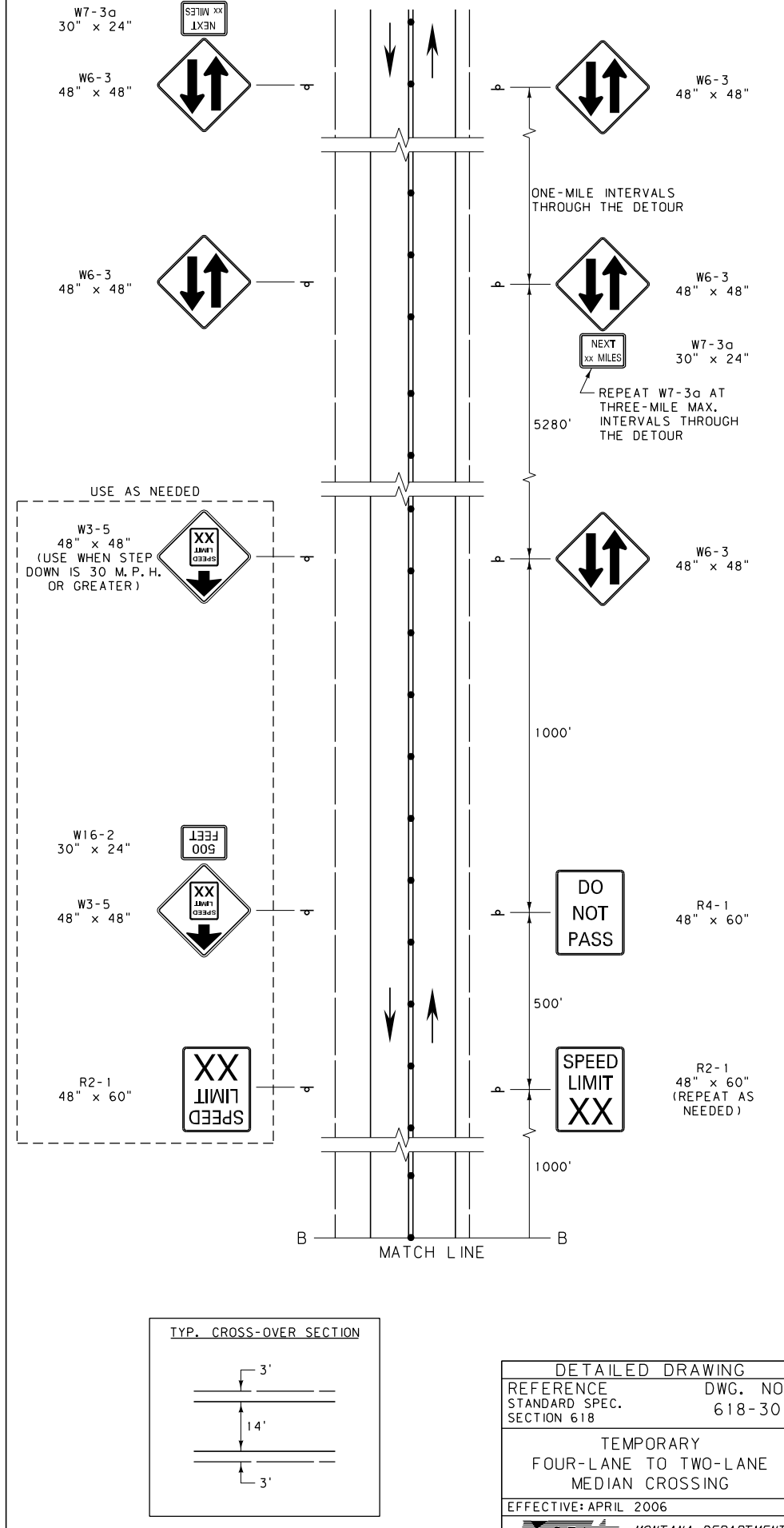
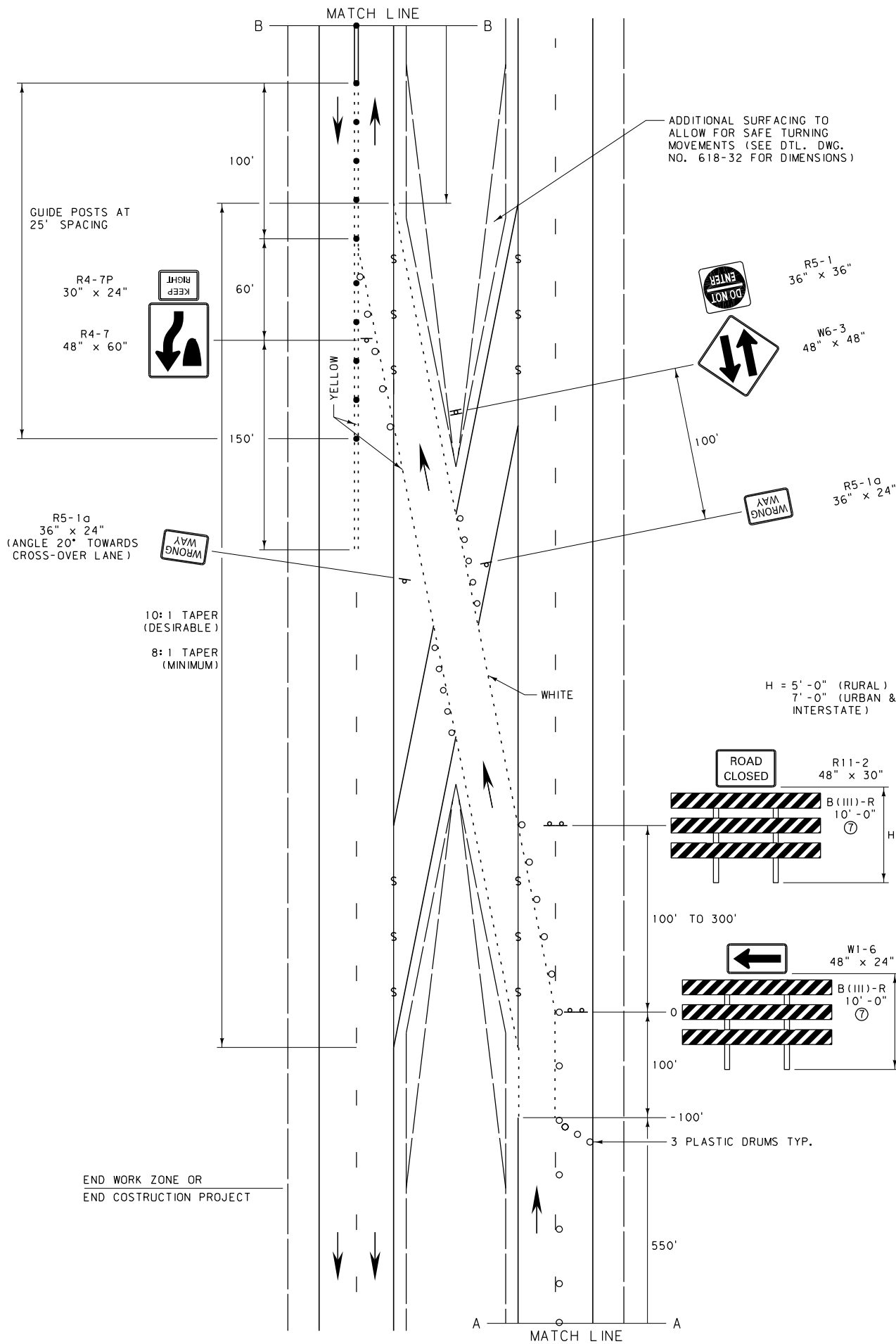

| | |
|--|-----------------|
| DETAILED DRAWING | |
| REFERENCE STANDARD SPEC. SECTION 618 | DWG. NO. 618-30 |
| TEMPORARY FOUR-LANE TO TWO-LANE MEDIAN CROSSING | |
| EFFECTIVE: APRIL 2006 | |
| MONTANA DEPARTMENT OF TRANSPORTATION <small>servicing you with pride</small> | |

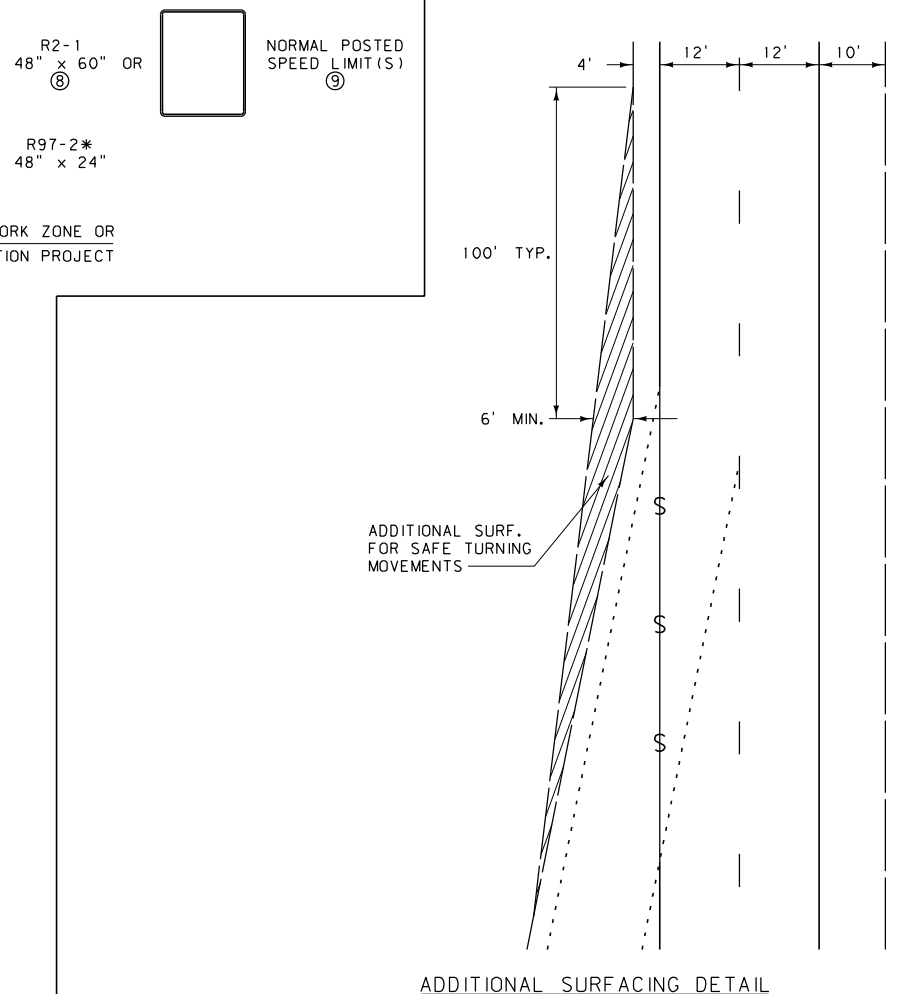
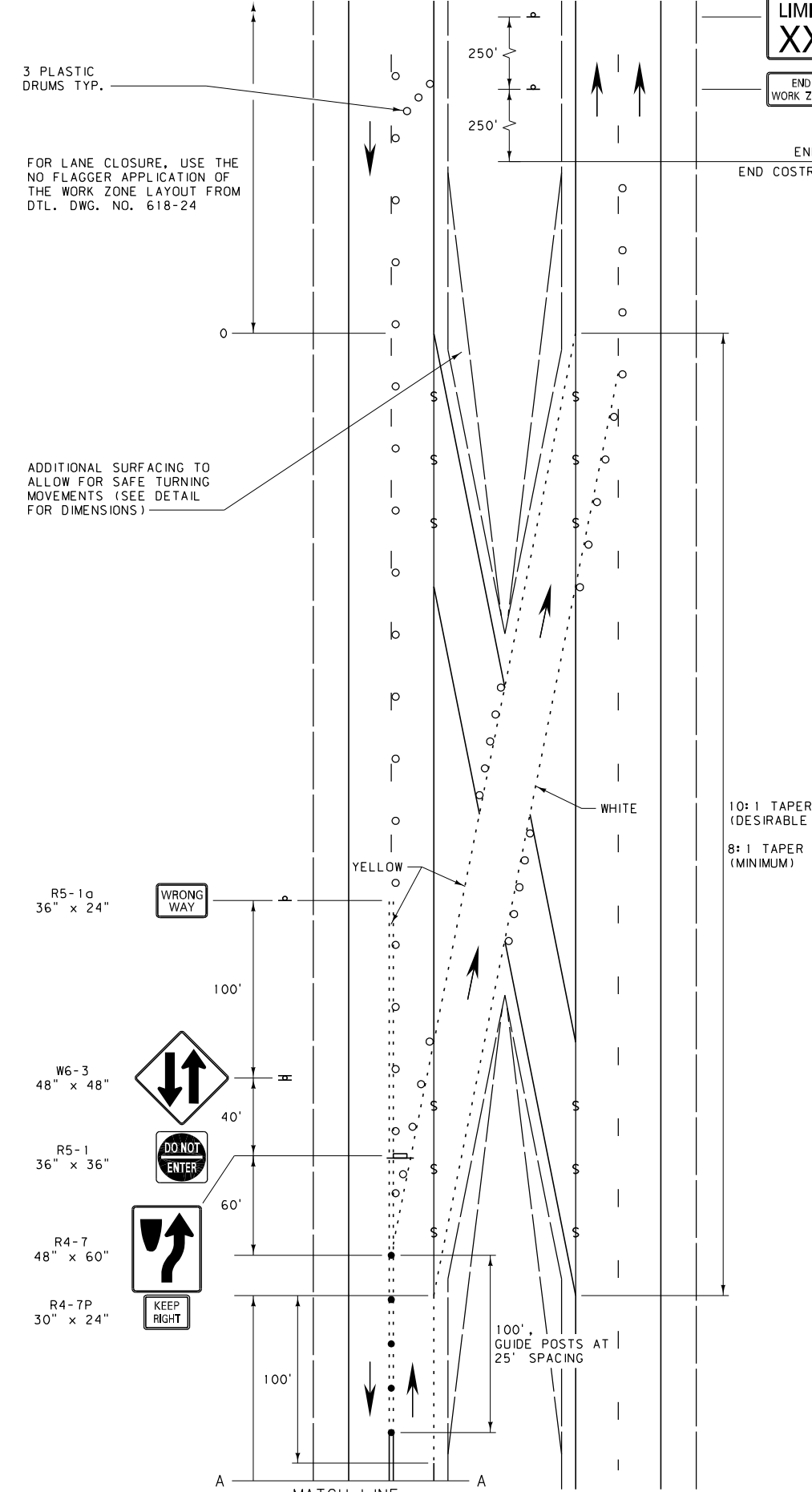
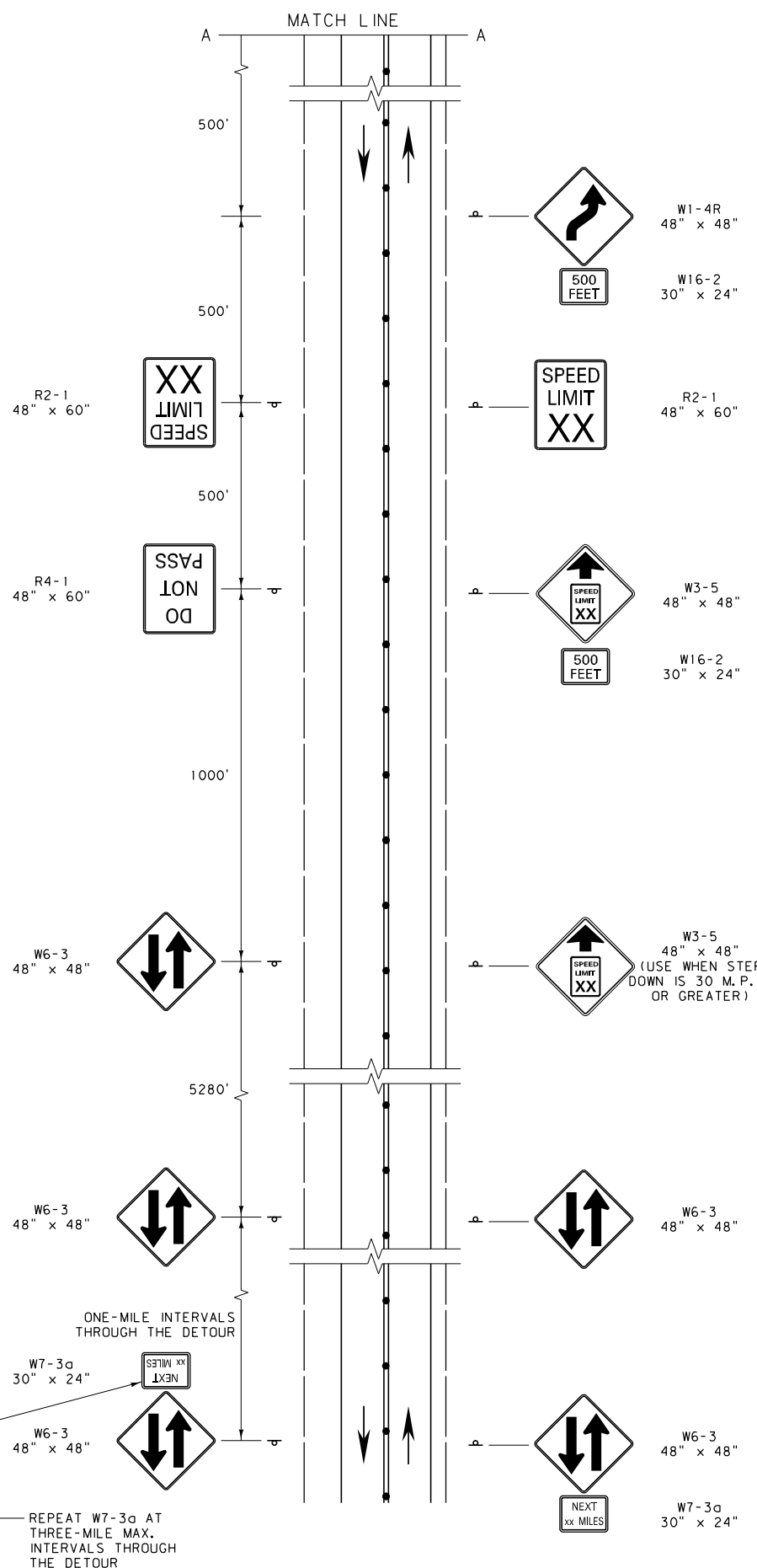

LEGEND

- OBLITERATE CONFLICTING PAVEMENT MARKINGS AND FILL ANY EXISTING RUMBLE STRIPS WITH PMS
- PLASTIC DRUMS (SEE NOTES FOR SPACING)
- - - - - RAISED RIGID PAVEMENT MARKERS TYPE I OR II AT 5' SPACING
- ==== DOUBLE YELLOW PAINT OR DOUBLE PLASTIC PAVEMENT MARKING TABS AT 5' SPACING
- FLEXIBLE GLUE-DOWN GUIDE POSTS ON TWO-LANE (SEE NOTES FOR SPACING EXCEPT AS SHOWN)

- NOTES:**
- ① INCLUDE REGULATORY SIGNING ONLY AS REQUIRED. MODIFY REGULATORY SIGNS TO MATCH ADJACENT REGULATIONS.
 - ② THE WORK ZONE REFERS TO THE AREA WITHIN THE CONSTRUCTION PROJECT WHERE WORK IS ACTUALLY TAKING PLACE.
 - ③ XX = SPEED DETERMINED BY THE MEDIAN CROSSING DESIGN SPEED OR THE ENGINEER.
 - ④ SEE DTL. DWG. NO. 618-30 FOR TYPICAL CROSS-OVER SECTION DIMENSIONS.
 - ⑤ INDICATED SPACINGS ARE INTENDED TO BE A MAXIMUM AND MAY BE REDUCED IF CONDITIONS WARRANT.
 - ⑥ SPACE CHANNELIZING DEVICES ON TANGENTS AT INTERVALS IN FEET OF NO MORE THAN TWO TIMES THE SPEED LIMIT IN M.P.H. AND ON ALL TAPER SECTIONS AT INTERVALS IN FEET OF NO MORE THAN ONE TIMES THE SPEED LIMIT IN M.P.H. FOR SPEED LIMITS LESS THAN 35 M.P.H., SPACE CHANNELIZING DEVICES AS DIRECTED BY THE ENGINEER.
 - ⑦ OBLITERATE ALL PAVEMENT MARKINGS THAT CONFLICT AT ANY TIME DURING OR AFTER MEDIAN CROSSING USE.
 - ⑧ POST THE END OF WORK ZONE SPEED LIMIT APPROPRIATE FOR ALL VEHICLES FOR THE REMAINDER OF THE CONSTRUCTION PROJECT BEFORE RESUMING TO NORMAL POSTED SPEED LIMITS AT THE END OF THE CONSTRUCTION PROJECT.
 - ⑨ WHEN AT THE END OF A CONSTRUCTION PROJECT, POST THE SPEED LIMIT CONSISTING OF ONE LIMIT WHEN THE NORMAL POSTED SPEED LIMIT FOR ALL VEHICLES IS THE SAME. WHEN CAR AND TRUCK SPEED LIMITS DIFFER, POST BOTH LIMITS ON A SINGLE SIGN.

DETAILED DRAWING

| | |
|--|-----------------|
| REFERENCE STANDARD SPEC. SECTION 618 | DWG. NO. 618-32 |
| TEMPORARY TWO-LANE TO FOUR-LANE MEDIAN CROSSING | |
| EFFECTIVE: APRIL 2006 | |
| MONTANA DEPARTMENT OF TRANSPORTATION <i>servicing you with pride</i> | |

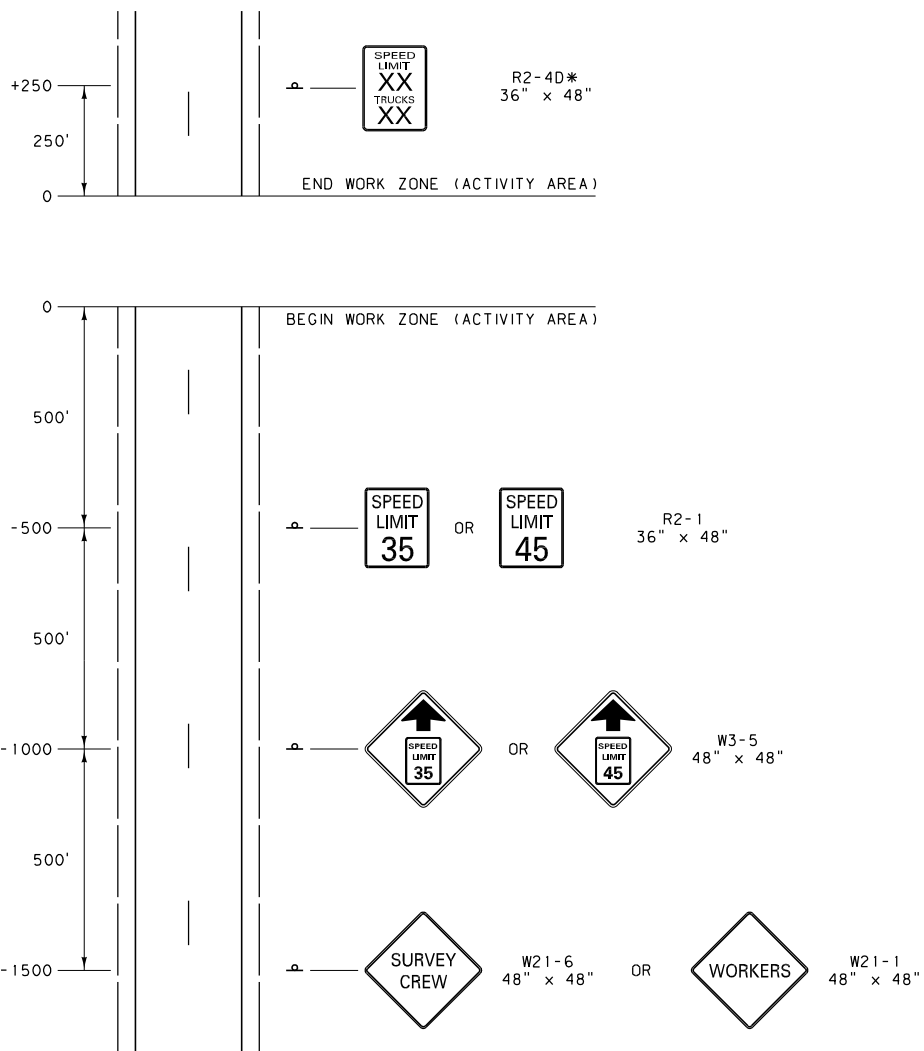

NOTES:

- ① SHORT DURATION ACTIVITIES ARE DEFINED AS THOSE LASTING UP TO ONE HOUR.
 - ② USE THIS SIGN LAYOUT WHEN WORK IS TO TAKE PLACE ON THE TRAVELED WAY. SIGNING FOR WORK ON OR NEAR THE SHOULDER MAY BE LIMITED TO THE USE OF ONE 48" WARNING SIGN FOR EACH TRAVEL DIRECTION. SIGNING FOR WORK OUTSIDE THE SHOULDER MAY BE LIMITED TO THE USE OF ONE 48" WARNING SIGN FOR THE TRAVEL DIRECTION ADJACENT TO THE WORK.
 - ③ SIGN BOTH TRAVEL DIRECTIONS ON TWO-LANE, TWO-WAY ROADWAYS OR BOTH SHOULDERS ON TWO-LANE, ONE-WAY ROADWAYS.
 - ④ PROVIDE AT LEAST THE DISTANCE SHOWN FOR DELINEATOR MOUNTED SIGNS.
 - ⑤ SEE DTL. DWG. NO. 618-36 "SHORT-TERM STATIONARY CREW SIGNING" IF THE DOUBLE PENALTY REGULATION IS TO BE UTILIZED.
 - ⑥ XX = NORMAL POSTED SPEED LIMIT(S).
- * DENOTES SIGNS THAT ARE UNIQUE TO MONTANA.

| | |
|--|-----------------|
| DETAILED DRAWING | |
| REFERENCE STANDARD SPEC. SECTION 618 | DWG. NO. 618-34 |
| SHORT DURATION CREW SIGNING | |
| EFFECTIVE: APRIL 2006 | |
|  MONTANA DEPARTMENT OF TRANSPORTATION <i>-serving you with pride</i> | |

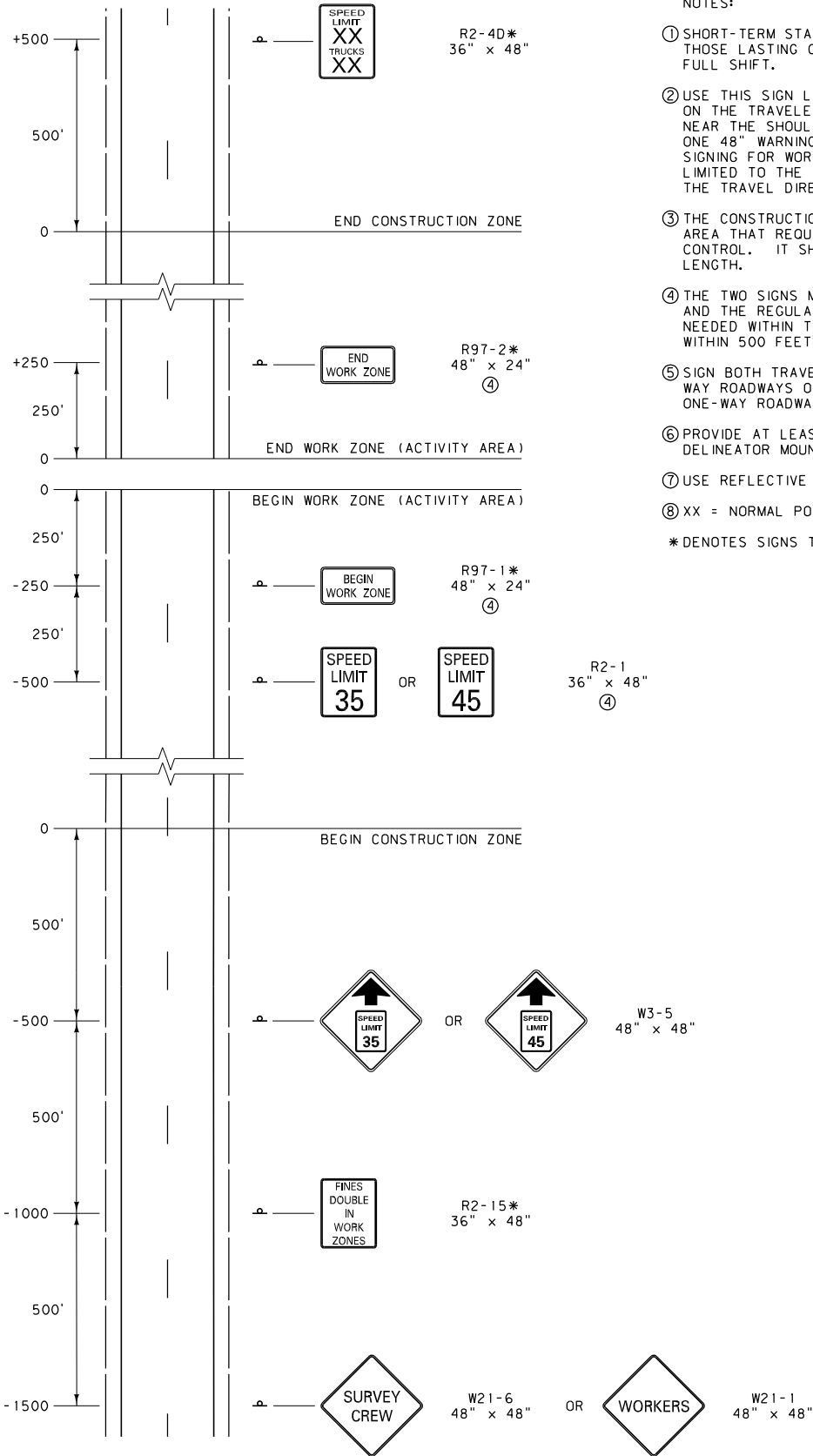

NOTES:

- ① SHORT-TERM STATIONARY ACTIVITIES ARE DEFINED AS THOSE LASTING GREATER THAN ONE HOUR, UP TO A FULL SHIFT.
- ② USE THIS SIGN LAYOUT WHEN WORK IS TO TAKE PLACE ON THE TRAVELED WAY. SIGNING FOR WORK ON OR NEAR THE SHOULDER MAY BE LIMITED TO THE USE OF ONE 48" WARNING SIGN FOR EACH TRAVEL DIRECTION. SIGNING FOR WORK OUTSIDE THE SHOULDER MAY BE LIMITED TO THE USE OF ONE 48" WARNING SIGN FOR THE TRAVEL DIRECTION ADJACENT TO THE WORK.
- ③ THE CONSTRUCTION ZONE REFERS TO THE GENERAL AREA THAT REQUIRES TEMPORARY WORK ZONE TRAFFIC CONTROL. IT SHOULD NOT EXCEED THREE MILES IN LENGTH.
- ④ THE TWO SIGNS MARKING THE WORK ZONE BOUNDARIES AND THE REGULATORY SPEED SIGN MUST MOVE AS NEEDED WITHIN THE CONSTRUCTION ZONE TO REMAIN WITHIN 500 FEET OF THE WORK ACTIVITY.
- ⑤ SIGN BOTH TRAVEL DIRECTIONS ON TWO-LANE, TWO-WAY ROADWAYS OR BOTH SHOULDERS ON TWO-LANE, ONE-WAY ROADWAYS.
- ⑥ PROVIDE AT LEAST THE DISTANCE SHOWN FOR DELINEATOR MOUNTED SIGNS.
- ⑦ USE REFLECTIVE DEVICES.
- ⑧ XX = NORMAL POSTED SPEED LIMIT(S).

* DENOTES SIGNS THAT ARE UNIQUE TO MONTANA.

| | |
|--|-----------------|
| DETAILED DRAWING | |
| REFERENCE STANDARD SPEC. SECTION 618 | DWG. NO. 618-36 |
| SHORT-TERM STATIONARY CREW SIGNING | |
| EFFECTIVE: APRIL 2006 | |
| MONTANA DEPARTMENT OF TRANSPORTATION <i>servicing you with pride</i> | |

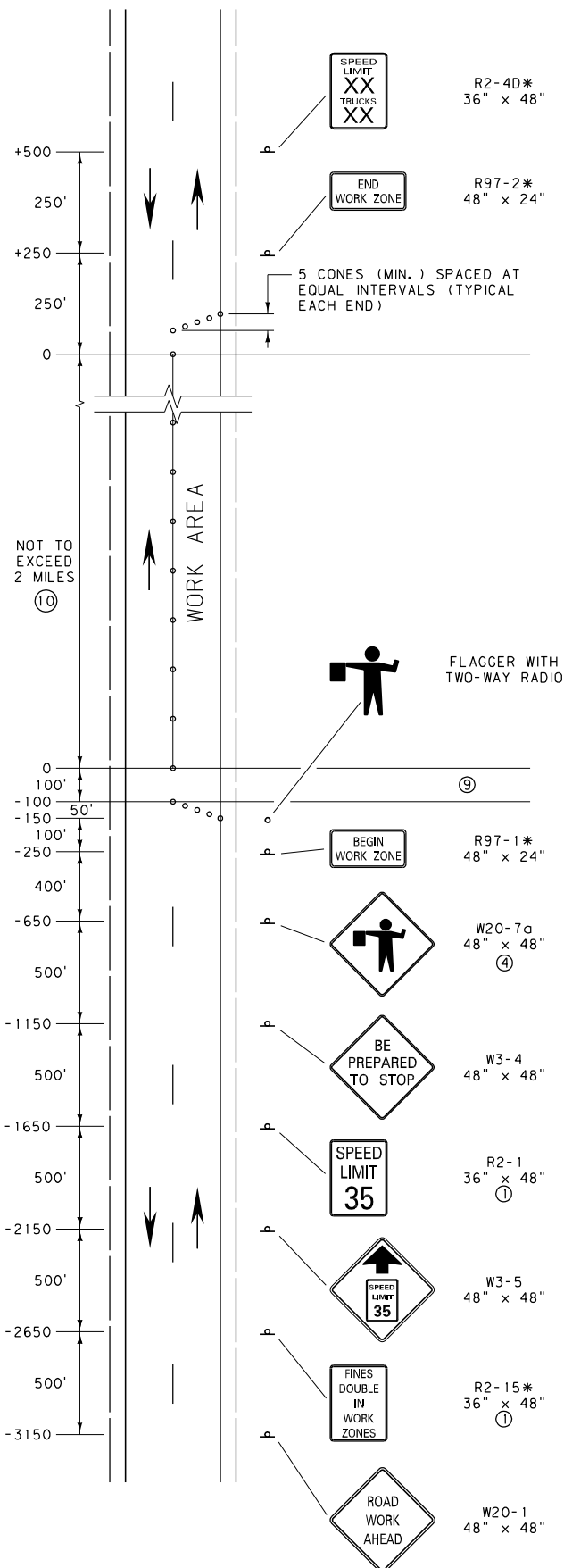

NOTES:

- ① MINIMUM REGULATORY SIGN SIZE IS 24" X 30" ON TWO-LANE ROADS.
- ② ON ROADWAYS WITH HIGH TRAFFIC VOLUMES OR VISIBILITY RESTRICTIONS, A 500' SPACING FOR ALL SIGNS IS RECOMMENDED.
- ③ SPACE CHANNELIZING DEVICES AT INTERVALS IN FEET OF TWICE THE SPEED LIMIT IN M.P.H. THROUGH THE BUFFER AND WORK AREA.
- ④ IF A NEED ARISES TO INCREASE VEHICLE STORAGE, ADD AN ADDITIONAL W20-7a "FLAGGER AHEAD" SIGN BETWEEN THE R2-1 AND W3-4 SIGNS AND/OR CONSIDER AN ADDITIONAL ADVANCE FLAGGER.
- ⑤ A MIRROR IMAGE OF THIS SIGN SEQUENCE IS REQUIRED FOR THE TRAFFIC FROM THE OPPOSITE DIRECTION.
- ⑥ FOR MORE INFORMATION OR CLARIFICATION CONTACT THE DISTRICT TRAFFIC ENGINEER. FOR EXAMPLE, IF WORK ZONE IS CLOSE TO A HORIZONTAL CURVE, A VERTICAL CURVE, A BRIDGE, INTERCHANGE, POOR SIGHT DISTANCE, OR OTHER SPECIAL CONDITION.
- ⑦ COVER ANY CONFLICTING SIGNS IN THE WORK ZONE.
- ⑧ SHORT-TERM WORK ZONE SIGNING IS NOT REQUIRED TO BE POST MOUNTED.
- ⑨ THE BUFFER SPACE CAN BE LATERAL AND LONGITUDINAL AND MAY BE INCREASED FOR DOWNGRADES AND OTHER CONDITIONS THAT AFFECT STOPPING DISTANCE.
- ⑩ TYPICALLY 2 MILES IS THE MAX. WORK AREA. HOWEVER, WHEN SIGHT DISTANCE, BUFFER ZONES OR ACCOMPLISHMENT RATES FOR EQUIPMENT ARE CONSIDERED, SOME MINOR ADJUSTMENTS TO THIS MAX. MAY BE CONSIDERED.
- ⑪ XX = NORMAL POSTED SPEED LIMIT(S).

* DENOTES SIGNS THAT ARE UNIQUE TO MONTANA.

| | |
|---|---|
| DETAILED DRAWING | |
| REFERENCE STANDARD SPEC. SECTION 618 | DWG. NO. 618-M1 |
| MAINTENANCE GUIDELINE FOR SHORT-TERM TWO-LANE CRACK SEALING WORK ZONE | |
| EFFECTIVE: APRIL 2006 | |
|  MTD <i>servicing you with pride</i> | MONTANA DEPARTMENT OF TRANSPORTATION |

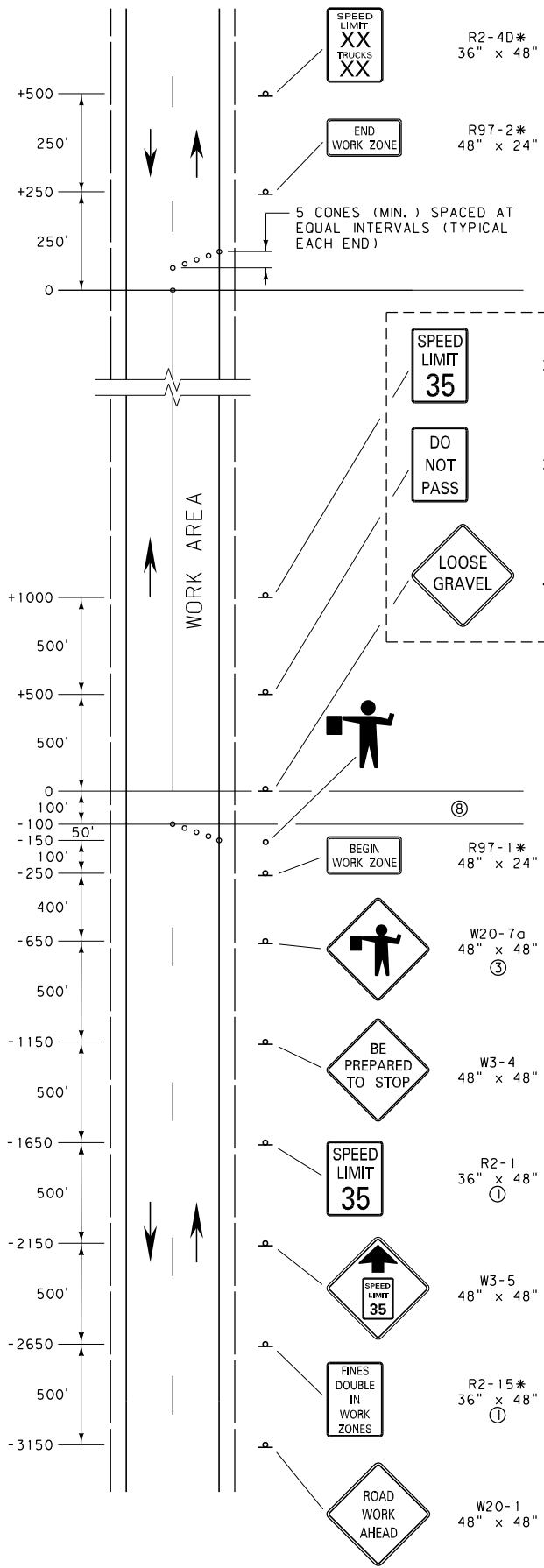

NOTE:
TO BE POSTED AT THE START OF THE WORK AND REPEATED AT TWO-MILE INTERVALS UNTIL THE SURFACE IS SWEEPED AND STRIPED.

NOTES:

- ① MINIMUM REGULATORY SIGN SIZE IS 24" x 30" ON TWO-LANE ROADS.
 - ② ON ROADWAYS WITH HIGH TRAFFIC VOLUMES OR VISIBILITY RESTRICTIONS, A 500' SPACING FOR ALL SIGNS IS RECOMMENDED.
 - ③ IF A NEED ARISES TO INCREASE VEHICLE STORAGE, ADD AN ADDITIONAL W20-7a "FLAGGER AHEAD" SIGN BETWEEN THE R2-1 AND W3-4 SIGNS AND/OR CONSIDER AN ADDITIONAL ADVANCE FLAGGER.
 - ④ A MIRROR IMAGE OF THIS SIGN SEQUENCE IS REQUIRED FOR THE TRAFFIC FROM THE OPPOSITE DIRECTION.
 - ⑤ FOR MORE INFORMATION OR CLARIFICATION CONTACT THE DISTRICT TRAFFIC ENGINEER. FOR EXAMPLE, IF WORK ZONE IS CLOSE TO A HORIZONTAL CURVE, A VERTICAL CURVE, A BRIDGE, INTERCHANGE, POOR SIGHT DISTANCE OR OTHER SPECIAL CONDITION.
 - ⑥ COVER ANY CONFLICTING SIGNS IN THE WORK ZONE.
 - ⑦ SHORT-TERM WORK ZONE SIGNING IS NOT REQUIRED TO BE POST MOUNTED.
 - ⑧ THE BUFFER SPACE CAN BE LATERAL AND LONGITUDINAL AND MAY BE INCREASED FOR DOWNGRADES AND OTHER CONDITIONS THAT AFFECT STOPPING DISTANCE.
 - ⑨ XX = NORMAL POSTED SPEED LIMIT(S).
- * DENOTES SIGNS THAT ARE UNIQUE TO MONTANA.

| DETAILED DRAWING | |
|--|-----------------|
| REFERENCE STANDARD SPEC. SECTION 618 | DWG. NO. 618-M2 |
| MAINT. GUIDELINE FOR SHORT-TERM TWO-LANE CHIP SEAL & OVERLAY (PILOTED TRAFFIC) | |
| EFFECTIVE: APRIL 2006 | |
| MONTANA DEPARTMENT OF TRANSPORTATION <i>servicing you with pride</i> | |

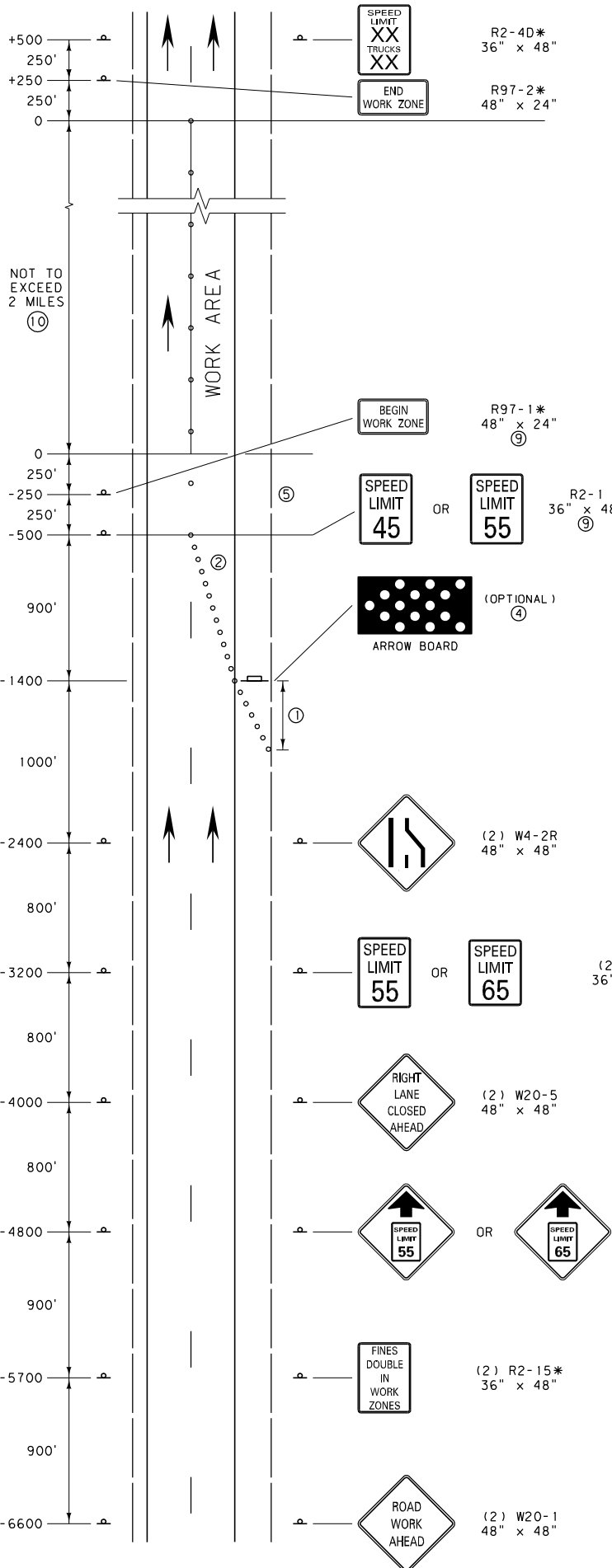

- NOTES:
- ① USE A MINIMUM 300' SHOULDER TAPER.
 - ② USE THIRTEEN APPROVED CHANNELIZING DEVICES FOR A 12' LANE CLOSURE TAPER (75 M.P.H. SPACED AT 75'.) ASSURE THAT THE TAPER IS A MINIMUM LENGTH OF 900'.
 - ③ SPACE CHANNELIZING DEVICES AT INTERVALS IN FEET OF TWICE THE SPEED LIMIT IN M.P.H. THROUGH THE BUFFER AND WORK AREA.
 - ④ PLACE THE ARROW BOARD (IF USED) ON THE SHOULDER AT THE START OF THE TRAVEL LANE CLOSURE TAPER.
 - ⑤ THE BUFFER SPACE CAN BE LATERAL AND LONGITUDINAL. KEEP THE BUFFER SPACE CLEAR OF EQUIPMENT AND PERSONNEL.
 - ⑥ FOR MORE INFORMATION OR CLARIFICATION CONTACT THE DISTRICT TRAFFIC ENGINEER. FOR EXAMPLE, IF WORK AREA IS CLOSE TO A HORIZONTAL CURVE, A VERTICAL CURVE, A BRIDGE, INTERCHANGE, POOR SIGHT DISTANCE OR OTHER SPECIAL CONDITION.
 - ⑦ COVER ANY CONFLICTING SIGNS IN THE WORK AREA.
 - ⑧ SHORT-TERM WORK ZONE SIGNING IS NOT REQUIRED TO BE POST MOUNTED.
 - ⑨ WHEN THE WORK ZONE CHANGES WITHIN THE CONSTRUCTION ZONE THESE SIGNS SHOULD BE MOVED TO REFLECT THE ACTUAL WORK ZONE.
 - ⑩ TYPICALLY 2 MILES IS THE MAX. WORK AREA. HOWEVER, WHEN SIGHT DISTANCE, BUFFER ZONES OR ACCOMPLISHMENT RATES FOR EQUIPMENT ARE CONSIDERED, SOME MINOR ADJUSTMENTS TO THIS MAX. MAY BE CONSIDERED.
 - ⑪ XX = NORMAL POSTED SPEED LIMIT(S).
- * DENOTES SIGNS THAT ARE UNIQUE TO MONTANA.

| | |
|--|-----------------|
| DETAILED DRAWING | |
| REFERENCE STANDARD SPEC. SECTION 618 | DWG. NO. 618-M3 |
| MAINTENANCE GUIDELINE FOR SHORT-TERM LANE CLOSURE ON INTERSTATE | |
| EFFECTIVE: APRIL 2006 | |
| MONTANA DEPARTMENT OF TRANSPORTATION <i>servicing you with pride</i> | |