

## ROUND PIPE

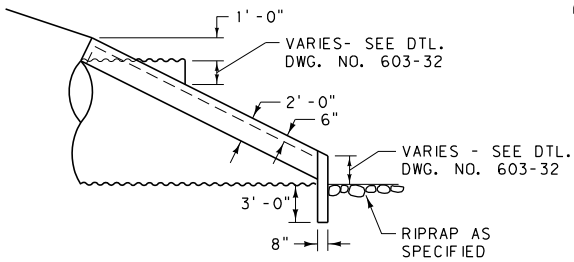

SIDE ELEVATION

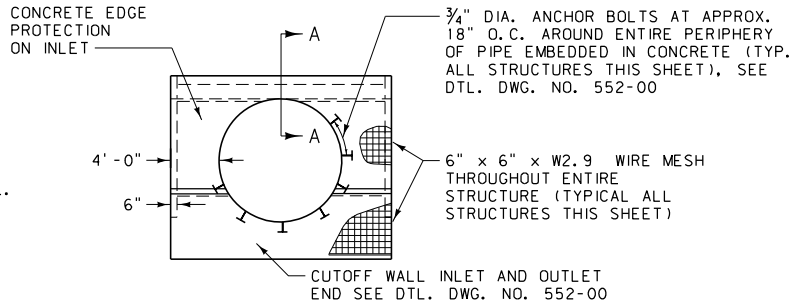

FRONT ELEVATION

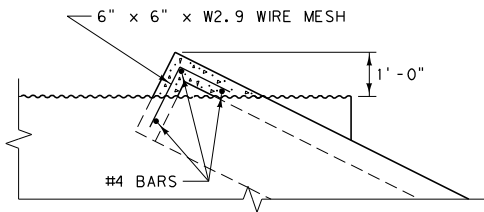

SECTION A-A

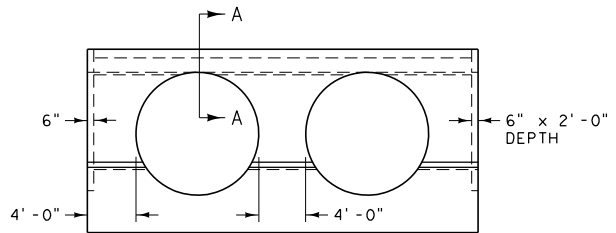

FRONT ELEVATION MULTIPLE PIPES

## ARCH PIPE

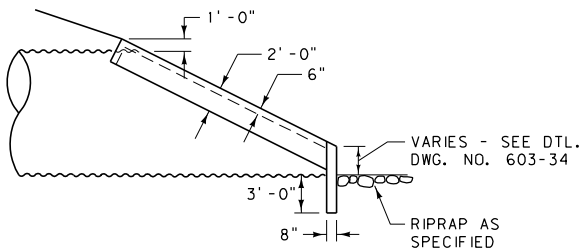

SIDE ELEVATION

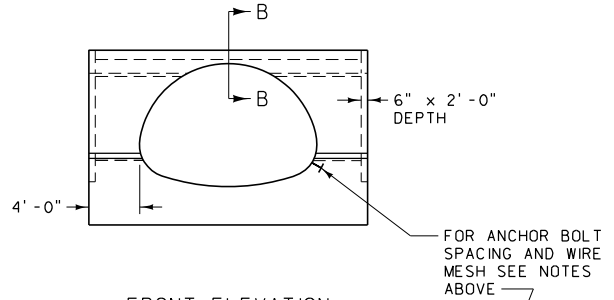

FRONT ELEVATION

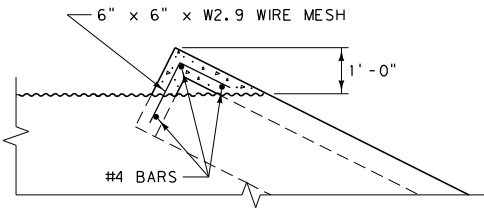

SECTION B-B

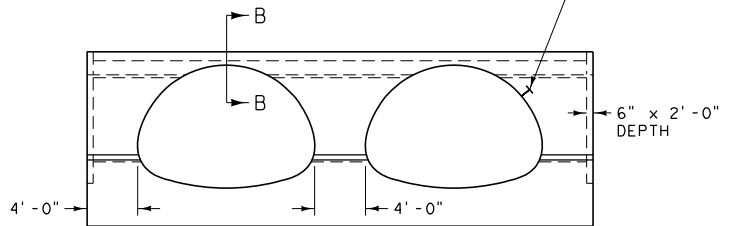

FRONT ELEVATION MULTIPLE PIPES

NOTES:  
ALL CONCRETE IS CLASS  
"DD" OR EQUAL.

DETAILED DRAWING	
REFERENCE STANDARD SPEC. SECTION 613	DWG. NO. 613-06
CONCRETE EDGE PROTECTION FOR METAL CULVERTS	
EFFECTIVE: FEBRUARY 2005	
<span style="font-weight: bold; font-size: small;">MONTANA DEPARTMENT OF TRANSPORTATION</span> <small>servicing you with pride</small>	

ROUND PIPE

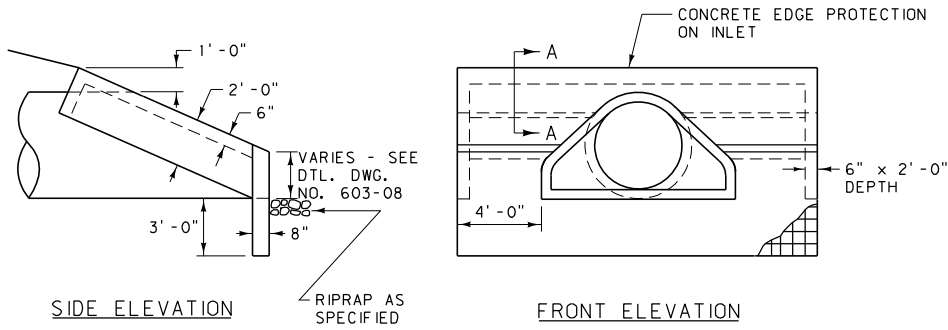

ARCH PIPE

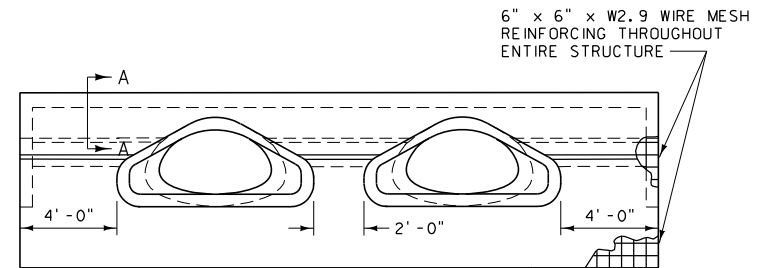
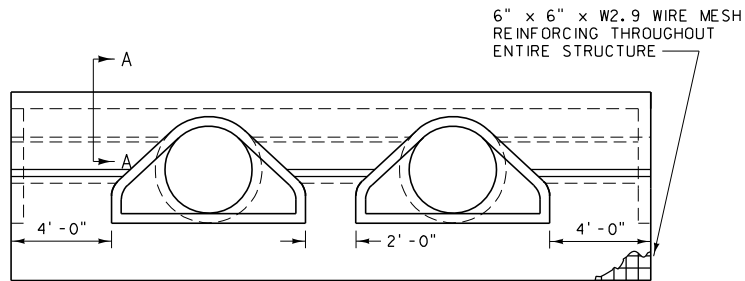
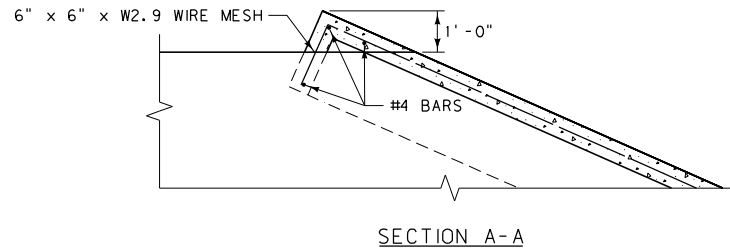
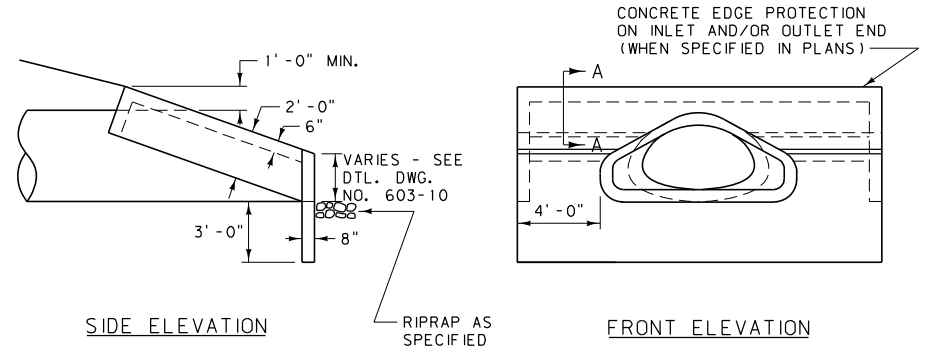

CUTOFF WALL INLET AND OUTLET END SEE DTL. DWG. NO. 552-00 (WHEN SPECIFIED IN PLANS)

NOTES:  
ALL CONCRETE IS CLASS "DD" OR EQUAL.

DETAILED DRAWING	
REFERENCE STANDARD SPEC. SECTION 603, 613	DWG. NO. 613-08

CONCRETE EDGE PROTECTION FOR CONCRETE CULVERTS

EFFECTIVE: FEBRUARY 2005

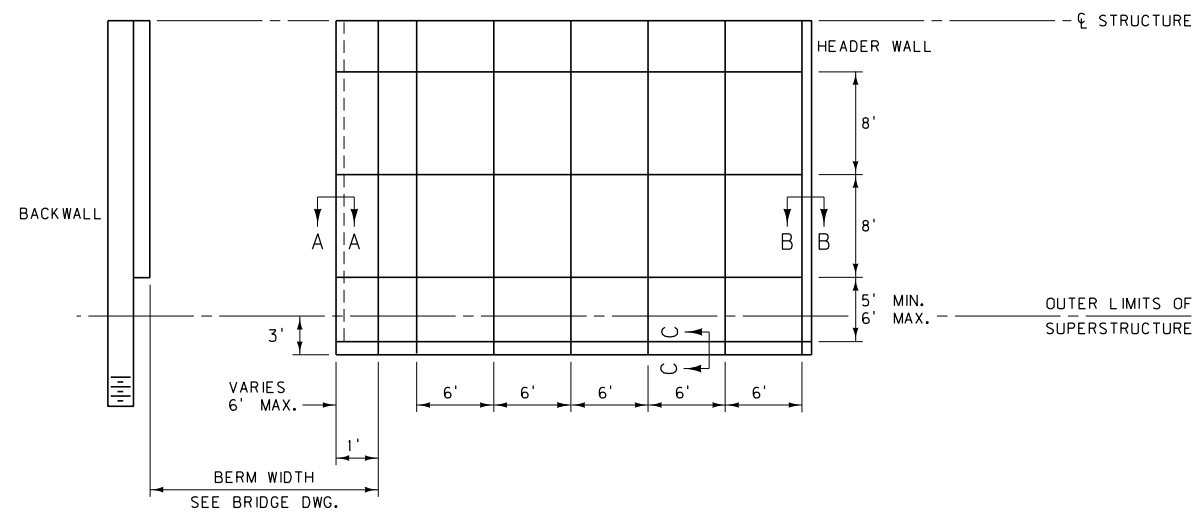

STRAIGHT STRUCTURE

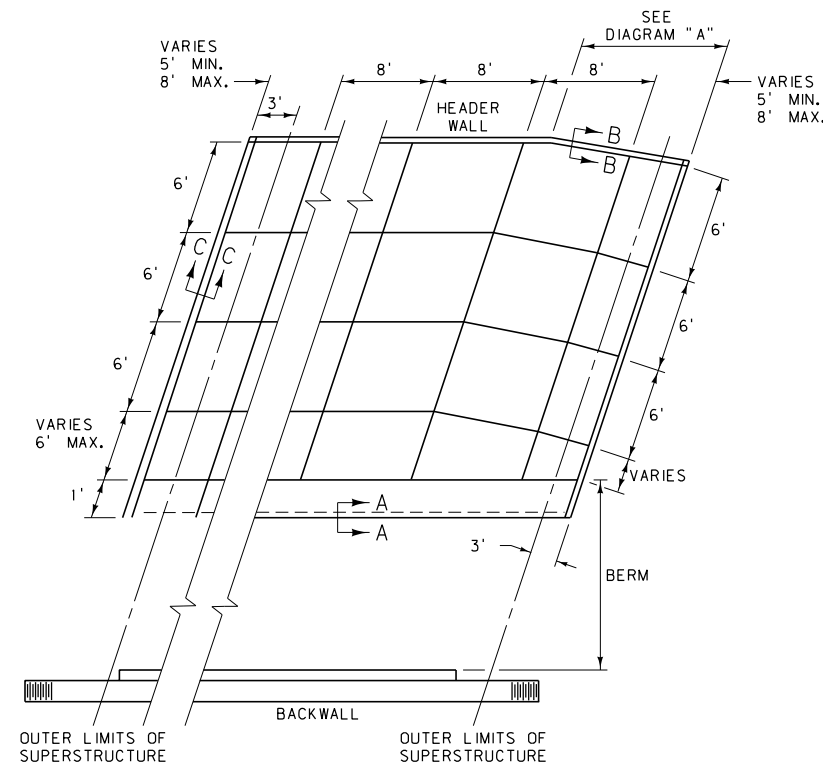

SKewed STRUCTURE

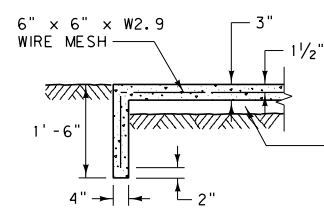

SECTION A-A

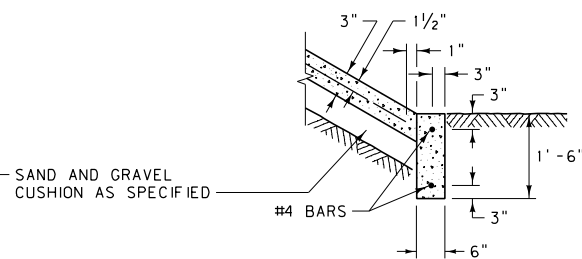

SECTION B-B  
HEADER WALL

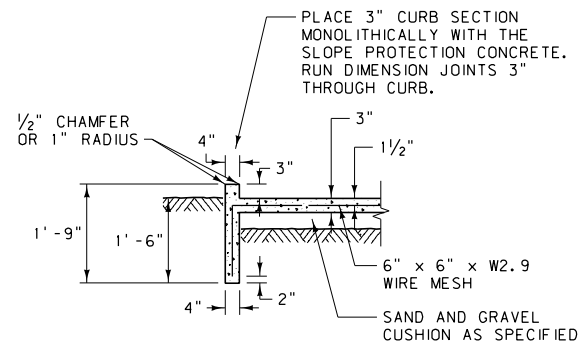

SECTION C-C

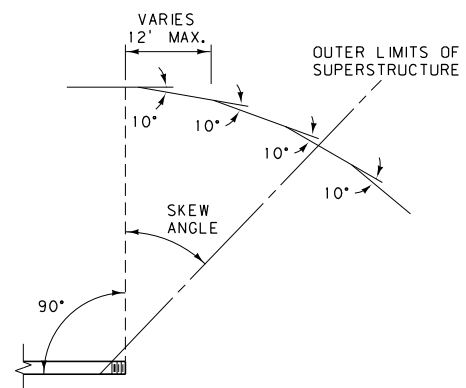

DIAGRAM "A"

CAST-IN-PLACE CONCRETE:

LOCATE JOINTS AS INDICATED ON THE PLANS. IF CONSTRUCTION IS STOPPED FOR OVER TWO HOURS, CREATE A CONSTRUCTION JOINT. USE CLASS "D" CONCRETE FOR ALL CAST-IN-PLACE CONCRETE.

USE AN APPROVED 1/2" EXPANSION JOINT FILLER WHENEVER THE CAST-IN-PLACE CONCRETE ABUTS AGAINST ANY PART OF THE BRIDGE STRUCTURE.

CLEAR THE EMBANKMENT SLOPE OF ALL BRUSH, DEBRIS AND RUBBLE. A CUSHION IS NOT REQUIRED FOR GRAVEL EMBANKMENT SLOPES. FINISH ALL SLOPES TO A REASONABLY UNIFORM SURFACE OR TO THE SLOPE INDICATED IN THE BRIDGE PLANS. COMPACT ALL LOOSE MATERIAL TO THE SATISFACTION OF THE ENGINEER. LEAVE THE ADJACENT SLOPE AREA IN A SMOOTH, UNIFORM CONDITION.

REINFORCING STEEL:

(MAY USE EITHER ALTERNATE LISTED BELOW)

- #3 BARS AT 10" O.C. (HORIZONTAL AND VERTICAL SPACING) MIN. COVER OF 2"
- 6" x 6" x W2.9 WIRE MESH

12" OVERLAP REQUIRED AT CONSTRUCTION JOINTS FOR REINFORCING STEEL AND WIRE MESH.

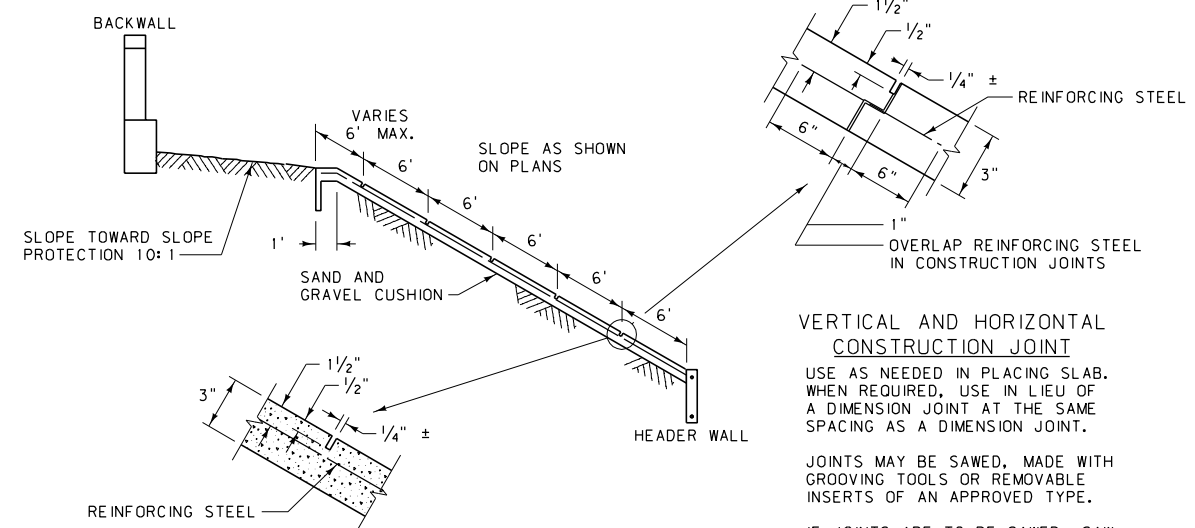

VERTICAL AND HORIZONTAL CONSTRUCTION JOINT

USE AS NEEDED IN PLACING SLAB. WHEN REQUIRED, USE IN LIEU OF A DIMENSION JOINT AT THE SAME SPACING AS A DIMENSION JOINT.

JOINTS MAY BE SAWED, MADE WITH GROOVING TOOLS OR REMOVABLE INSERTS OF AN APPROVED TYPE.

IF JOINTS ARE TO BE SAWED, SAW JOINTS JUST AFTER CONCRETE HAS SET BUT BEFORE UNCONTROLLED CRACKING OCCURS.

VERTICAL AND HORIZONTAL DIMENSION JOINT

6' VERTICAL SPACING OR AS NOTED.  
8' HORIZONTAL SPACING OR AS NOTED.  
JOINTS MAY BE SAWED, MADE WITH GROOVING TOOLS OR REMOVABLE INSERTS OF AN APPROVED TYPE.

DETAILED DRAWING	
REFERENCE STANDARD SPEC. SECTION 613	DWG. NO. 613-10

CONCRETE SLOPE PROTECTION

EFFECTIVE: FEBRUARY 2005

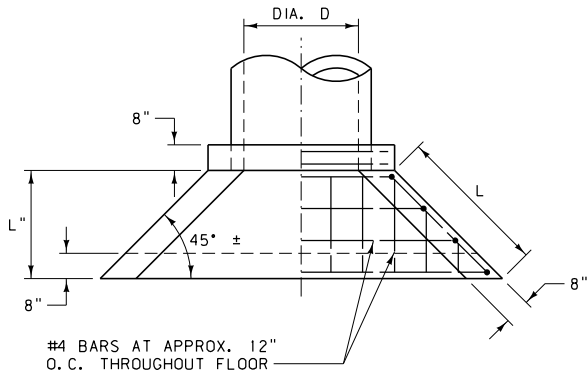

PLAN

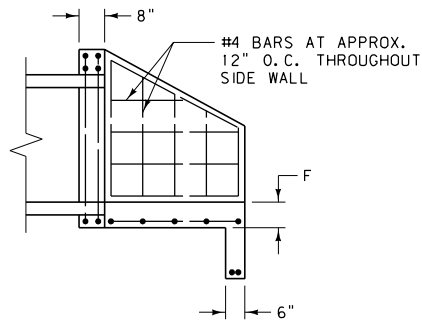

SECTION B-B

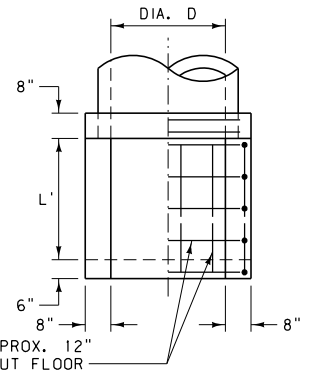

PLAN

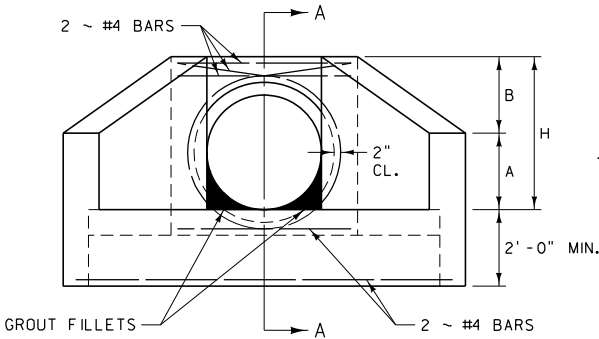

ELEVATION  
INLET HEADWALL

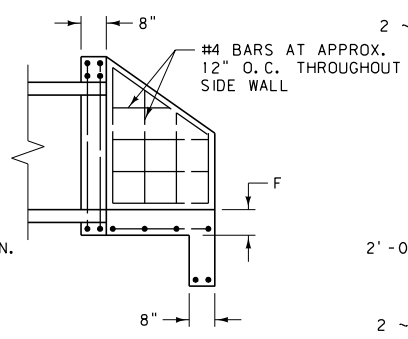

SECTION A-A

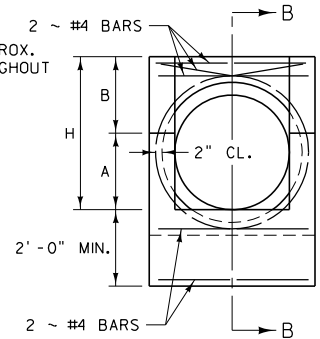

ELEVATION  
OUTLET HEADWALL

CHAMFER ALL EXPOSED CORNERS 1". REINFORCING STEEL TO BE NOT LESS THAN 1/2" TO NEAREST FACE OF CONCRETE.

INLET AND OUTLET HEADWALLS FOR RCP										
CULVERT		CL. "DD" CONC. OR EQUAL (C. Y.)		DIMENSION TABLE						
DIA. D	AREA (SQ. FT.)	INLET	OUTLET	A	B	H	L	L"	F	L'
18"	1.77	0.80	0.60	1'-3"	1'-3"	2'-6"	2'-6"	1'-9"	6 1/2"	2'-2"
24"	3.14	1.00	0.86	1'-6"	1'-6"	3'-0"	3'-0"	2'-1"	7"	2'-6"
30"	4.91	1.42	1.14	1'-9"	1'-9"	3'-6"	3'-6"	2'-6"	7 1/2"	2'-10"
36"	7.07	1.84	1.43	2'-0"	2'-0"	4'-0"	4'-0"	2'-10"	8"	3'-2"
42"	9.62	2.12	1.73	2'-3"	2'-3"	4'-6"	4'-6"	3'-2"	8 1/2"	3'-6"
48"	12.57	2.34	2.07	2'-6"	2'-6"	5'-0"	5'-0"	3'-6"	9"	3'-10"

INLET AND OUTLET HEADWALLS FOR CMP										
CULVERT		CL. "DD" CONC. OR EQUAL (C. Y.)		DIMENSION TABLE						
DIA. D	AREA (SQ. FT.)	INLET	OUTLET	A	B	H	L	L"	F	L'
18"	1.77	0.73	0.59	1'-3"	1'-3"	2'-6"	2'-6"	1'-9"	6"	2'-2"
24"	3.14	0.91	0.76	1'-6"	1'-6"	3'-0"	3'-0"	2'-1"	6"	2'-6"
30"	4.91	1.06	0.95	1'-9"	1'-9"	3'-6"	3'-6"	2'-6"	6"	2'-10"
36"	7.07	1.68	1.11	2'-0"	2'-0"	4'-0"	4'-0"	2'-10"	6"	3'-2"
42"	9.62	2.10	1.40	2'-3"	2'-3"	4'-6"	4'-6"	3'-2"	6"	3'-6"
48"	12.57	2.32	1.66	2'-6"	2'-6"	5'-0"	5'-0"	3'-6"	6"	3'-10"

DETAILED DRAWING	
REFERENCE STANDARD SPEC. SECTION 613	DWG. NO. 613-12
INLET AND OUTLET HEADWALLS FOR RCP AND CMP PIPES	
EFFECTIVE: FEBRUARY 2005	
 serving you with pride	MONTANA DEPARTMENT OF TRANSPORTATION

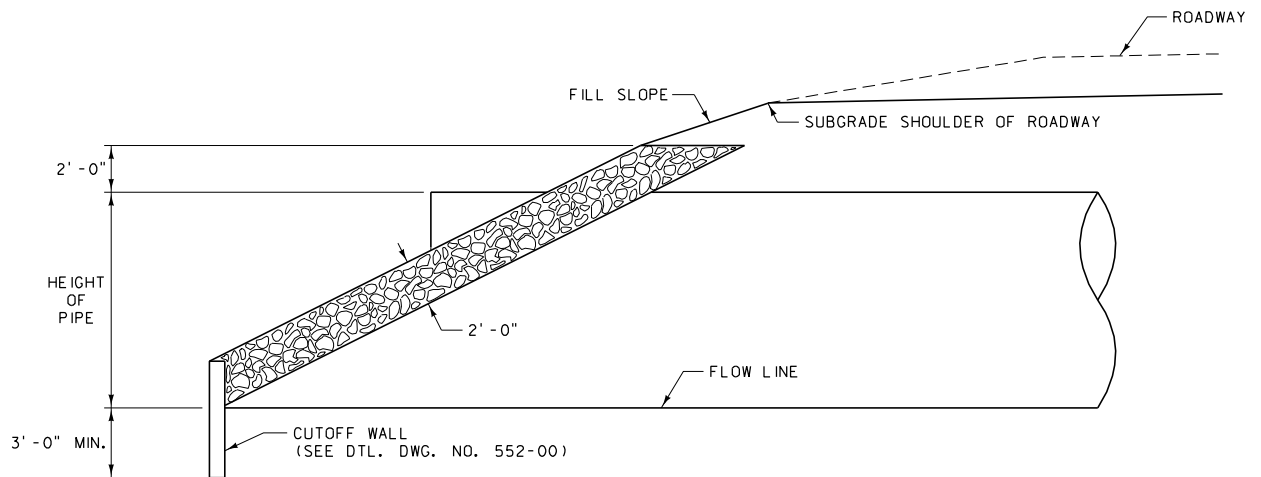
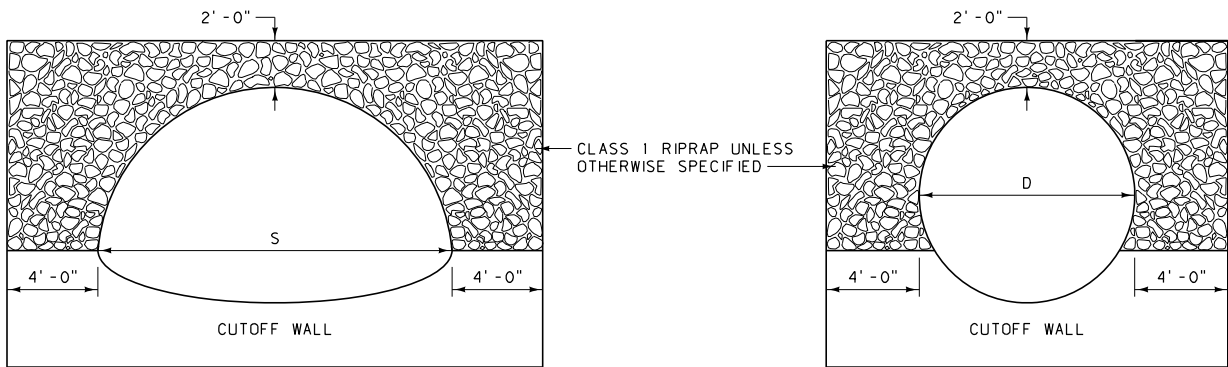

NOTES:

KEY ENDS OF RIPRAP WALLS INTO THE EMBANKMENT SLOPES A MINIMUM OF 2 FEET FROM OUTER FACE OF THE RIPRAP FOR THE FULL HEIGHT OF THE RIPRAP WALL.

SEE SPECIFICATIONS FOR GRADATION, CLASS AND CONSTRUCTION METHODS.

DETAILED DRAWING	
REFERENCE STANDARD SPEC. SECTION 613	DWG. NO. 613-14
CULVERT RIPRAP	
EFFECTIVE: FEBRUARY 2005	
 <b>MONTANA DEPARTMENT OF TRANSPORTATION</b> <i>-serving you with pride</i>	

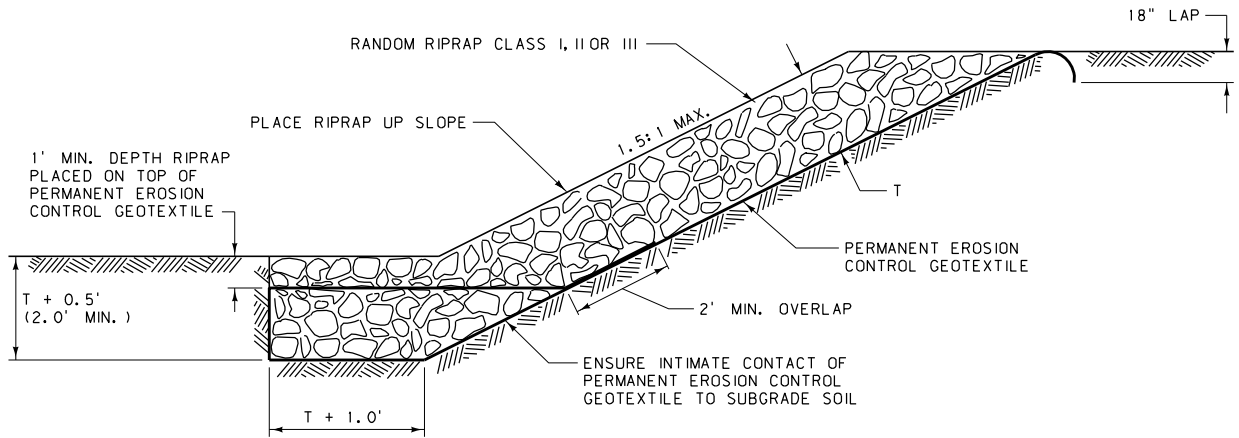

**EMBANKMENT PROTECTION**

MINIMUM T FOR:  
 CLASS I RIPRAP = 1.5'  
 CLASS II RIPRAP = 2.5'  
 CLASS III RIPRAP = 3.0'

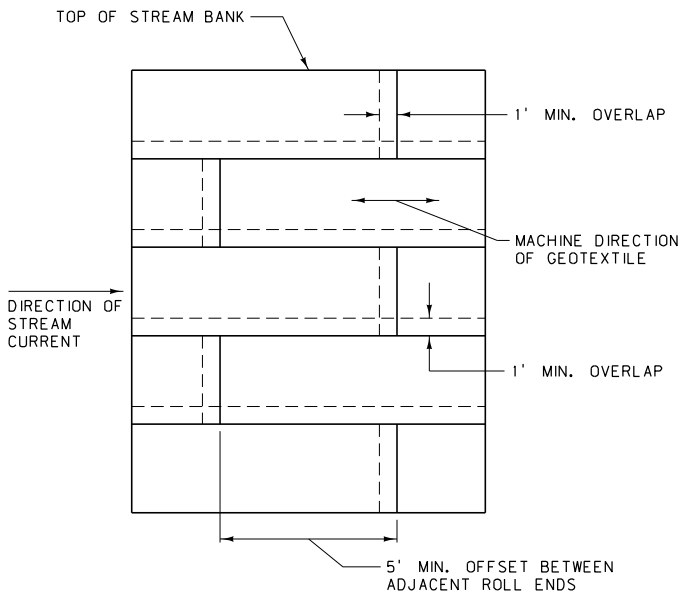

**GEOTEXTILE PLACEMENT DETAIL**

METHOD FOR PLACING PERMANENT EROSION CONTROL GEOTEXTILE FOR PROTECTION OF STREAM BANKS

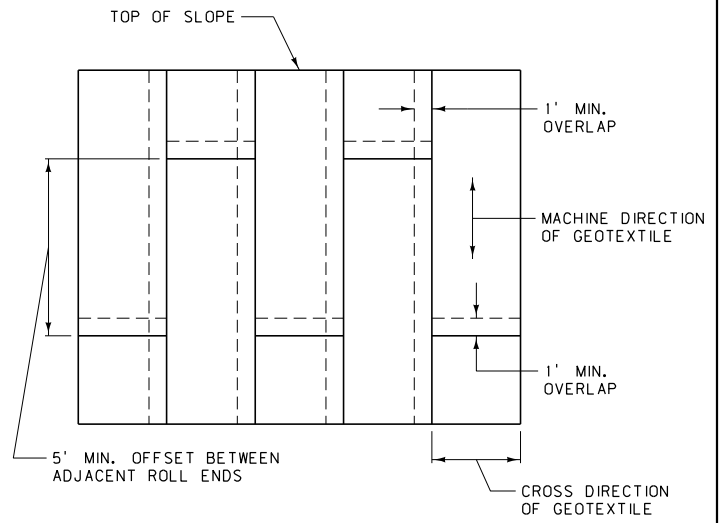

**GEOTEXTILE PLACEMENT DETAIL**

METHOD FOR PLACING PERMANENT EROSION CONTROL GEOTEXTILE FOR PROTECTION OF CUT AND FILL SLOPES

**NOTES:**

INSTALL PERMANENT EROSION CONTROL GEOTEXTILE IN ACCORDANCE WITH MANUFACTURER'S SPECIFICATIONS AND MDT STANDARD SPECIFICATIONS SECTION 622.

PROVIDE PERMANENT EROSION CONTROL GEOTEXTILE MEETING MDT STANDARD SPECIFICATIONS SECTION 716.

DETAILED DRAWING	
REFERENCE STANDARD SPEC. SECTION 613, 622	DWG. NO. 613-16
EMBANKMENT PROTECTION	
EFFECTIVE: APRIL 2006	
 MONTANA DEPARTMENT OF TRANSPORTATION <i>-serving you with pride</i>	

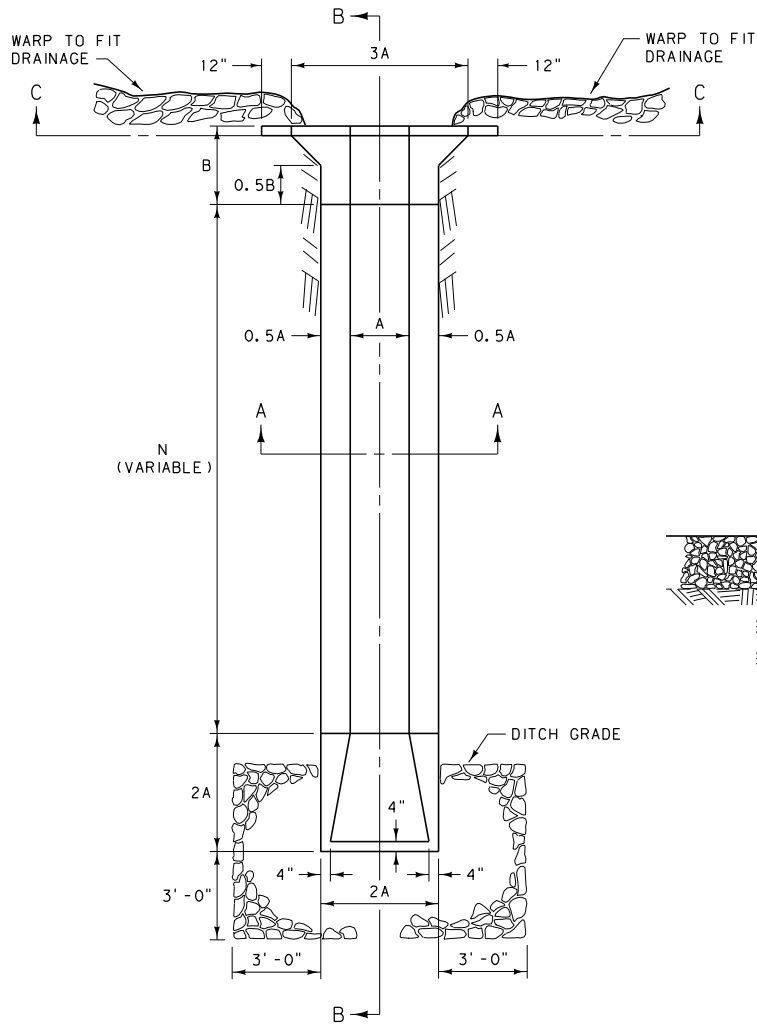

**CONCRETE:**

USE CLASS "AC" OR "DC" CONCRETE UNLESS OTHERWISE NOTED, CONFORMING TO SECTION 551 OF THE STANDARD SPECIFICATIONS. CONCRETE MAY BE PNEUMATICALLY APPLIED.

**\* BANK PROTECTION:**

USE TYPE III BANK PROTECTION, CONFORMING TO SUBSECTION 613.03.2 OF THE STANDARD SPECIFICATIONS. THICKNESS IS 12" MIN.

**INLET CONDITIONS:**

DEPRESS THE INLET BELOW THE NATURAL DRAINAGE BASIN TO PREVENT FLOW FROM SIDE CHANNELING OVER THE SLOPE BEFORE REACHING THE CHUTE.

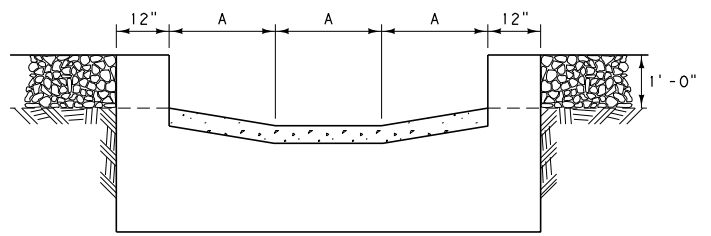

SECTION C-C

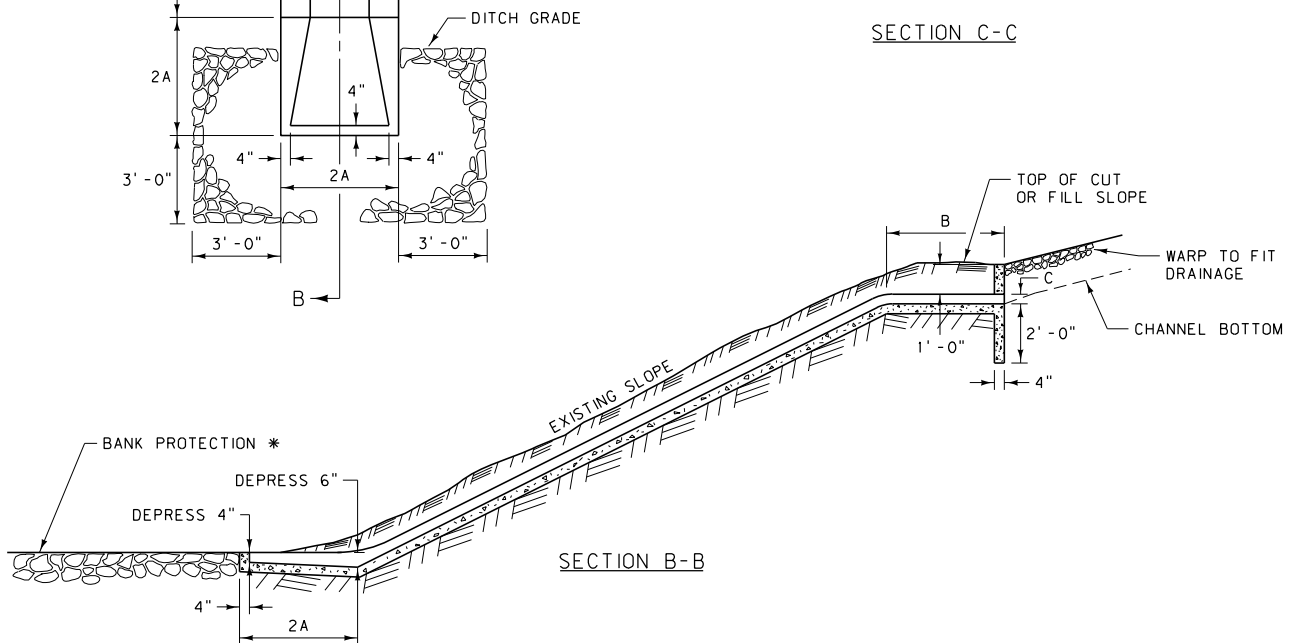

SECTION B-B

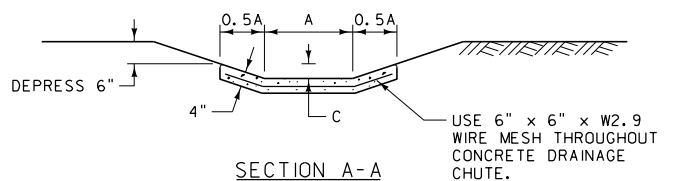

SECTION A-A

TYPE	DIMENSIONS			QUANTITIES
	A	B	C	CONCRETE
1	2' - 0"	4' - 0"	0' - 4"	0.7 C.Y. + N x 0.051 C.Y. /L.F.
2	2' - 0"	4' - 0"	1' - 0"	0.9 C.Y. + N x 0.056 C.Y. /L.F.
3	4' - 0"	8' - 0"	1' - 0"	2.2 C.Y. + N x 0.105 C.Y. /L.F.
4	4' - 0"	8' - 0"	1' - 6"	2.3 C.Y. + N x 0.111 C.Y. /L.F.

DETAILED DRAWING	
REFERENCE STANDARD SPEC. SECTION 551, 613	DWG. NO. 613-18
CONCRETE DRAINAGE CHUTE	
EFFECTIVE: FEBRUARY 2005	
 <b>MONTANA DEPARTMENT OF TRANSPORTATION</b> <i>servicing you with pride</i>	