

SECTION A-A

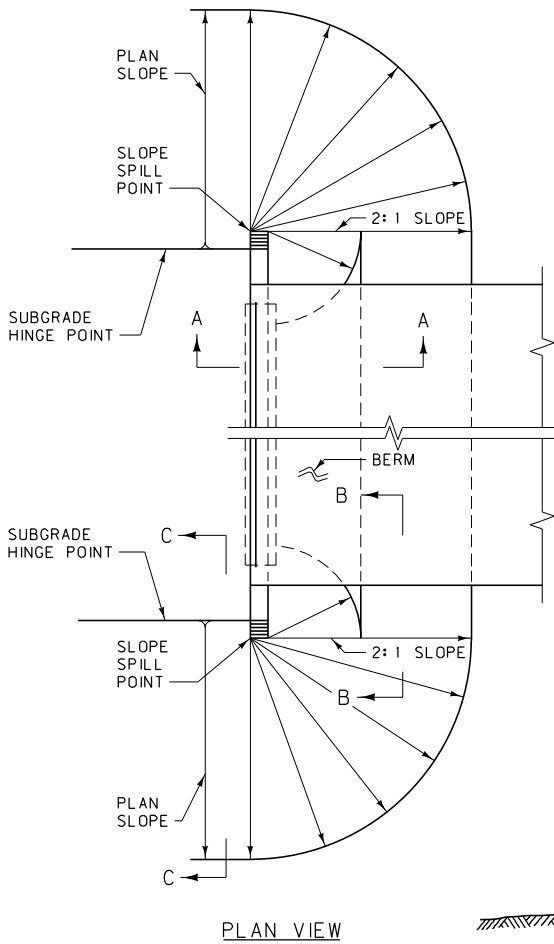

PLAN VIEW

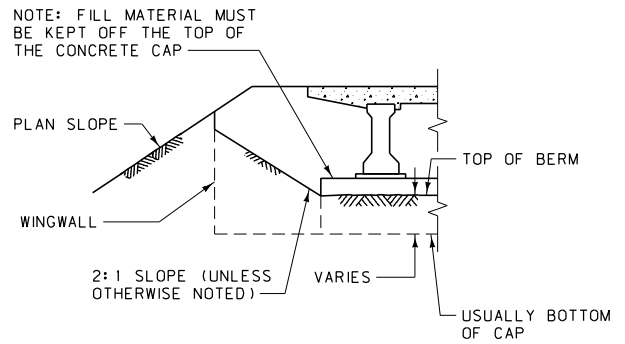

SECTION B-B

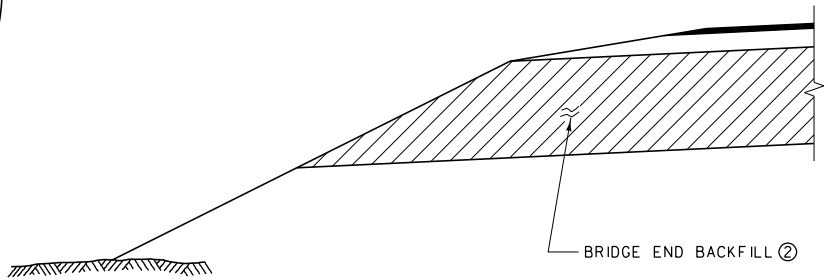

SECTION C-C

- NOTES:
- ① DO NOT PLACE THE BRIDGE END BACKFILL UNTIL AFTER THE BACKWALL AND DECK SLAB ARE COMPLETED. PLACE ALL MATERIAL IN 6" LAYERS AND COMPACT IN ACCORDANCE WITH SECTION 203.03.3 OF THE STANDARD SPECIFICATIONS.
 - ② WHEN THE BRIDGE END BACKFILL DOES NOT DAYLIGHT AT AN EMBANKMENT SLOPE TO PROVIDE DRAINAGE, EXTEND THE BRIDGE END BACKFILL 3 FEET BEYOND THE WINGWALL AND DAYLIGHT TO THE SLOPE FACING THE SPANNED CHANNEL.

DETAILED DRAWING	
REFERENCE STANDARD SPEC. SECTION 203	DWG. NO. 203-00
ROADWAY EMBANKMENT AT BRIDGE END	
EFFECTIVE: FEBRUARY 2005	
-- REVISED -- January 2008	 MONTANA DEPARTMENT OF TRANSPORTATION serving you with pride

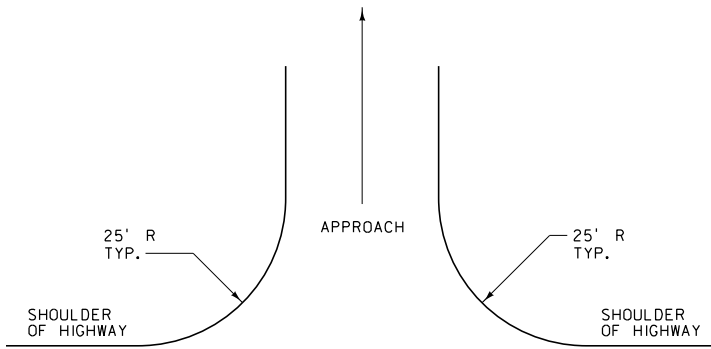

NOTE: MAX. SKEW ANGLE IS 30°.

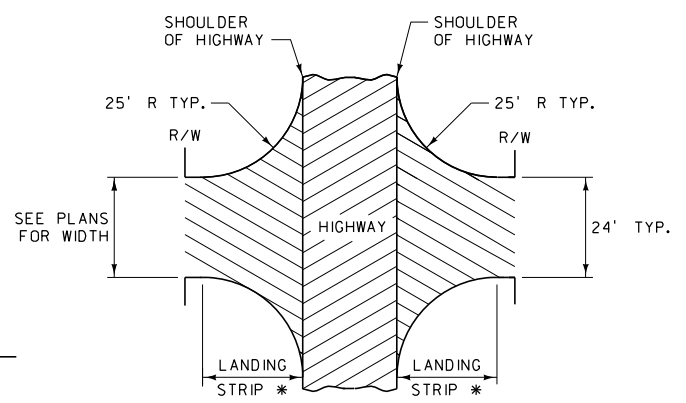

* 25.0' MIN. FOR PRIVATE OR FIELD APP.
75.0' MIN FOR COUNTY AND MAIN ROADS.
SLOPE FOR DRAINAGE (-3% DESIRABLE, +3% ALLOWABLE).

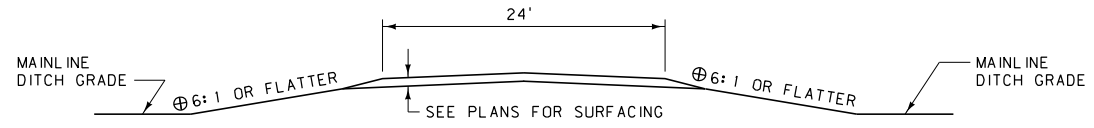

TYPICAL SECTION WITHIN CLEAR ZONE

USE A PIPE AS NECESSARY FOR DRAINAGE. INSTALL CULVERTS OUTSIDE THE CLEAR ZONE OR PROVIDE END TREATMENT.

⊕ 10:1 SLOPES ARE DESIRABLE ON HIGH SPEED FACILITIES WHERE PRACTICAL

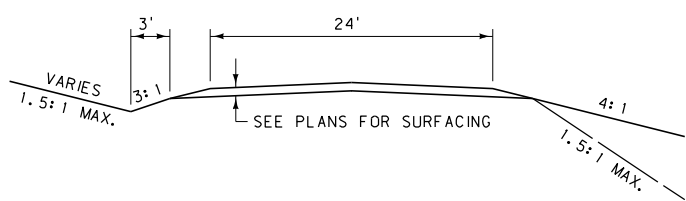

TYPICAL SECTION BEYOND CLEAR ZONE

BACK SLOPES **	
0' - 5'	4: 1
5' - 10'	2: 1
OVER 10'	1.5: 1

FILL SLOPES **	
0' - 10'	4: 1
10' - 20'	2: 1
OVER 20'	1.5: 1

NOTES:
APPROACH GRADE BEYOND LANDING IS NOT TO EXCEED 10% UNLESS TRAFFIC VOLUMES AND COST INDICATE SUCH TO BE JUSTIFIABLE.

CONSTRUCT APPROACHES TO FIT LOCAL CONDITIONS, MINIMIZE TRAFFIC HAZARDS, AND AFFORD ENTRY AND EXIT OF TRAFFIC TO AND FROM THE MAIN ROAD.

SECURE WRITTEN PERMISSION FROM LANDOWNER FOR WORK BEYOND THE RIGHT-OF-WAY.

** CRITERIA SHOWN ARE FOR PRIVATE AND FARM FIELD APPROACHES. FOR COUNTY AND MAIN ROADS USE ESTABLISHED STANDARDS FOR APPLICABLE FUNCTIONAL CLASS.

DETAILED DRAWING	
REFERENCE STANDARD SPEC. SECTION 203	DWG. NO. 203-05
APPROACHES	
EFFECTIVE: FEBRUARY 2005	
 MONTANA DEPARTMENT OF TRANSPORTATION <i>servicing you with pride</i>	

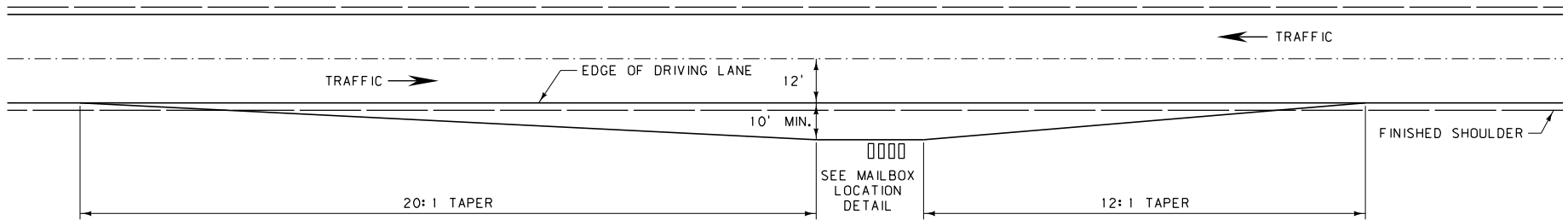

TURNOUT WITHOUT APPROACH

NOTE:
ACTUAL SIZE AND LOCATION TO BE DETERMINED BY
THE ENGINEER.

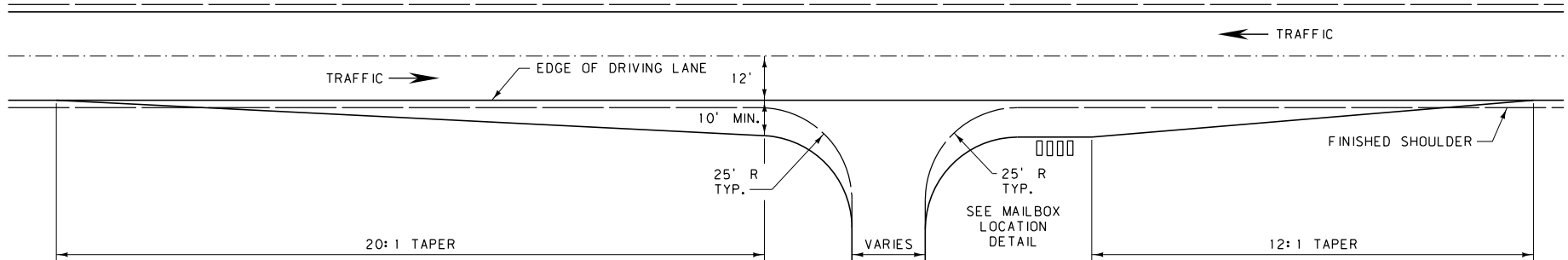

TURNOUT WITH APPROACH

NOTES:

LOCATE NEW INSTALLATIONS, IF POSSIBLE, ON THE FAR RIGHT SIDE OF AN INTERSECTION WITH A PUBLIC ROAD OR PRIVATE DRIVEWAY.

APPROACH QUANTITIES ARE NOT INCLUDED IN TURNOUT QUANTITIES.

USE THIS DETAIL FOR ALL ROADS AND ADT. FOR ADT LESS THAN 400, STEEPER TAPERS ARE ALLOWED IF NEEDED DUE TO LIMITATIONS. SEE THE "AASHTO GUIDE FOR ERECTING MAILBOXES ON HIGHWAYS."

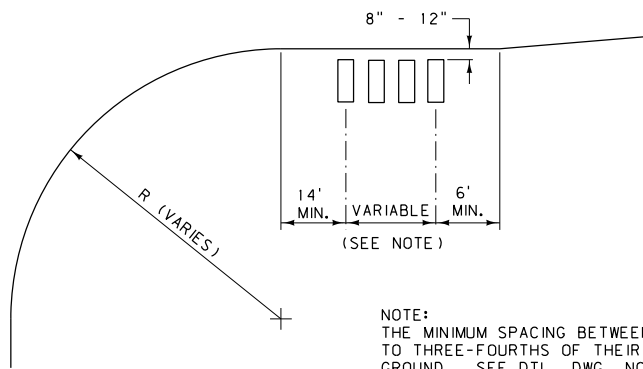

NOTE:
THE MINIMUM SPACING BETWEEN MAILBOXES IS EQUAL TO THREE-FOURTHS OF THEIR HEIGHT ABOVE THE GROUND. SEE DTL. DWG. NO. 900-05 AND 900-10 FOR MAILBOX DETAILS.

MAILBOX LOCATION DETAIL

DETAILED DRAWING	
REFERENCE STANDARD SPEC. SECTION 203	DWG. NO. 203-15
MAILBOX TURNOUT	
EFFECTIVE: FEBRUARY 2005	
 MONTANA DEPARTMENT OF TRANSPORTATION <i>serving you with pride</i>	

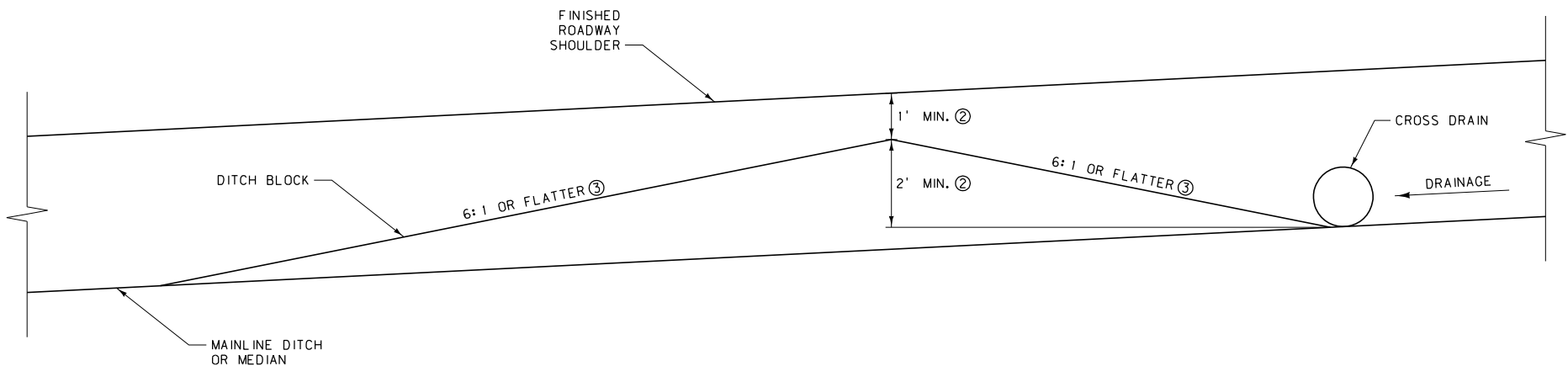

NOTES:

- ① CONSTRUCT DITCH BLOCKS TO FIT LOCAL CONDITIONS.
- ② HEIGHTS SHOWN ARE MINIMUMS. SET HEIGHT OF DITCH BLOCKS BASED ON AMOUNT OF ANTICIPATED DRAINAGE.
- ③ 10:1 SLOPES ARE DESIRABLE ON HIGH SPEED FACILITIES WHERE PRACTICAL.

DETAILED DRAWING	
REFERENCE STANDARD SPEC. SECTION 203	DWG. NO. 203-20
DITCH BLOCKS	
EFFECTIVE: FEBRUARY 2005	
 MONTANA DEPARTMENT OF TRANSPORTATION <i>serving you with pride</i>	